



Owner's Manual

Polo



Owner's Manual:
Polo
Stand: 30.11.2022
Englisch: 04.2024
Artikel-Nr.: 25A.5L1.POL.20

Thank you for choosing Volkswagen

By purchasing this Volkswagen, you have become the owner of a vehicle fitted with the most up-to-date technology and a multitude of convenience functions for your use and enjoyment.

Before using your vehicle for the first time, carefully read and observe the information in this Owner's Manual to become familiar with your vehicle and all of its functions, in addition to learning about the potential dangers to yourself and others and how to avoid them.

If you have any further questions about your vehicle, or if you think that the manual set has not covered everything, please contact your local Volkswagen Dealership. Volkswagen Dealerships are always happy to deal with your questions, suggestions or issues.

We hope you have a great driving experience in your new vehicle. Happy motoring.

Volkswagen do Brasil



Table of Contents

About this Owner's Manual	4	Lights	
Description of symbols	5	– Turn signals	79
		– Driving lights	79
		– Interior lighting	85
Owner's Manual		Visibility	
Overview of the vehicle		– Window wipers and washers	86
– Front view	6	– Mirrors	88
– Side view	7	– Sliding headliner	92
– Rear view	8	Heating and air conditioning	
– Driver door	9	– Heating, ventilating, cooling	92
– Driver's side	10	Driving	
– Centre console	11	– Driving guidelines	97
– Front passenger side	12	– Starting and stopping the engine	104
– Symbols in the roof headliner	12	– Start-Stop System	108
Driver's information		– Manual gearbox	110
– Warning lamps and indicator lamps	13	– Automatic gearbox	111
– Instrument cluster	14	– Uphill assist system	115
– Dash panel insert operation	27	– Steering assistance	116
– Radio controls and display	28	– Driving mode selection	117
Safety		Driver assist systems	
– Overall guidelines	31	– Cruise control system (GRA)	118
– Adjusting the seat position	32	Parking and manoeuvring	
– Seat belts	34	– Parking	120
– Airbag system	42	– Handbrake	121
– Transporting children in the vehicle	49	– Parking systems safety instructions	122
– In an emergency	58	– Park distance control (Park Pilot)	122
Open and close		– Rear view camera system	125
– Vehicle key	60	– Brake support systems	127
– Keyless locking and starting system "Keyless Access"	62	Practical equipment	
– Central locking button and doors	63	– Stowage compartment	130
– Anti-theft alarm system	68	– Cup holder	134
– Interior monitoring system	68	– Ashtray and cigarette lighter	135
– Boot lid	69	– Socket	136
– Windows	71	Radios	
Steering wheel		– Before using the unit for the first time	137
– Adjusting the steering wheel position	73	– Other applicable documents	137
Seats and head restraints		– Convenience overview	137
– Front seat	74	– Safety recommendations	138
– Rear seats	75	– Instructions for use	139
– Head restraints	77	– Power management	140
– Seat functions	78	– Anti-theft coding	140
		– Display	140

Composition Touch (R 340G)

– Device overview	141
– Basic command information	142
– Connectivity	144
– Unit operation	147
– Media mode	150
– Wired or wireless connections	154
– Phone	157
– Settings	165

VW Play

– Welcome to VW Play	167
– Device overview	167
– Quick access screens	168
– Radio	168
– Media	169
– Connect	170
– App store	171
– Apple CarPlay™	172
– Android Auto™	173
– Settings	174

Transporting

– Stowing items of luggage	178
– Luggage compartment	178
– Roof carrier	182
– Towing a trailer	184

Fuel

– Fuel handling safety guidelines	189
– Fuelling and fuel types	189
– Engine control unit and exhaust gas emission control system	192
– Fuel quality	194

If and when

– Vehicle toolkit	194
– Window wiper blades	196
– Exterior lighting	197
– Fuses	204
– Jump starting	209
– Tow starting and towing	212

Checking and refuelling

– In the engine compartment	213
– Service fluids and consumables	216
– Washer fluid	217
– Engine oil	218
– Engine coolant	222
– Brake fluid	224

– Warm starting system (E-FLEX)	226
– Vehicle battery	226

Wheels and tyres

– Tyre monitoring system	231
– Important information on wheels and tyres	233
– Hub caps	243
– Changing a wheel	244

Maintenance

– Service	249
– Vehicle conservation	252
– Accessories, modifications, repairs and part replacement	260

Consumer information

– Volkswagen warranty	265
– Additional service offers	265
– Information stickers and plates	266
– Aerial and radio feed	267
– Installing the radio	267
– Headphones	267
– Declarations of conformity	267

Technical data

– Guidelines on the technical data	269
– Information on fuel consumption	269
– Vehicle identification data	270
– Information on the air conditioner	271
– Dimensions	272
– Capacities	273
– Petrol engines	274
– TOTALFLEX engines	277

Abbreviations	280
----------------------	-----

Index	282
--------------	-----

About this Owner's Manual

This Owner's Manual is valid for all available models and versions of this vehicle. The Owner's Manual describes all of the equipment and models, without identifying as special equipment or model variations. Thus, there may be pieces of equipment described which are not included in your vehicle or which are only available to specific markets. The equipment contained in your vehicle is detailed in the product's sale documentation. Contact your local Volkswagen Dealership for further information.

All data in this Owner's Manual correspond to the information available at the time of going to print. Due to continuous technical improvement of the vehicle, actual vehicle features and equipment may differ from the indications provided in this manual. No discrepancy in data, illustrations or descriptions shall form the basis for any legal claim.

Please ensure that the complete manual set is always in the vehicle when lending or selling the vehicle.

- An [alphabetical index](#) is included at the end of this manual.
- A [list of abbreviations](#) detailing technical terms and acronyms can be found at the end of the manual.
- [Directions and positions](#) such as left, right, front and rear are normally relative to the vehicle's direction of travel, unless otherwise indicated.
- [Illustrations](#) assist with orientation and should be regarded as schematic representations.
- [Short definitions](#) highlighted before some of the sections in this manual, summarize the functions and use of a system or piece of equipment. Further information on the systems and equipment, apart from their features, commands and system limitations, is found in the respective sections.
- Any technical changes made to the vehicle after publication of this booklet are provided in a [Supplement](#) that is included with the manual set.

Standard booklets in the manual set:

- Owner's Manual
- Service Registry Booklet (for markets without digital service plan) (*may not be available for some countries*)

Additional booklets in the manual set (optional):

- Supplement



Description of symbols



Refers to an excerpt within a chapter that contains important information and safety notes . Such reference must always be observed.



Indicates that the section is continued on the next page.



Indicates the end of a section.



Indicates situations in which the vehicle must be stopped as quickly as possible.



The symbol indicates a registered trademark. However, the absence of this symbol does not constitute a waiver of the rights concerning any term.



Symbols of this type reference warnings



within the same section or page, indicating potential risks of accidents and injuries, as well as how they can be avoided.



Cross reference to information about possible damage to your vehicle within the same section or on a given page.



DANGER

Texts with this symbol indicate extremely dangerous situations, which may lead to fatal or severe injuries if you do not observe the warning.



WARNING

Texts with this symbol indicate dangerous situations which will lead to fatal or severe injuries if you do not observe the warning.



CAUTION

Texts with this symbol indicate dangerous situations, which may lead to light or severe injuries if you do not observe the warning.



NOTICE

Texts with this symbol indicate dangerous situations, which may lead to vehicle damages if you do not observe the warning.



Texts with this symbol are environment preservation recommendations.



Texts with this symbol contain additional information.



Overview of the vehicle

Front view

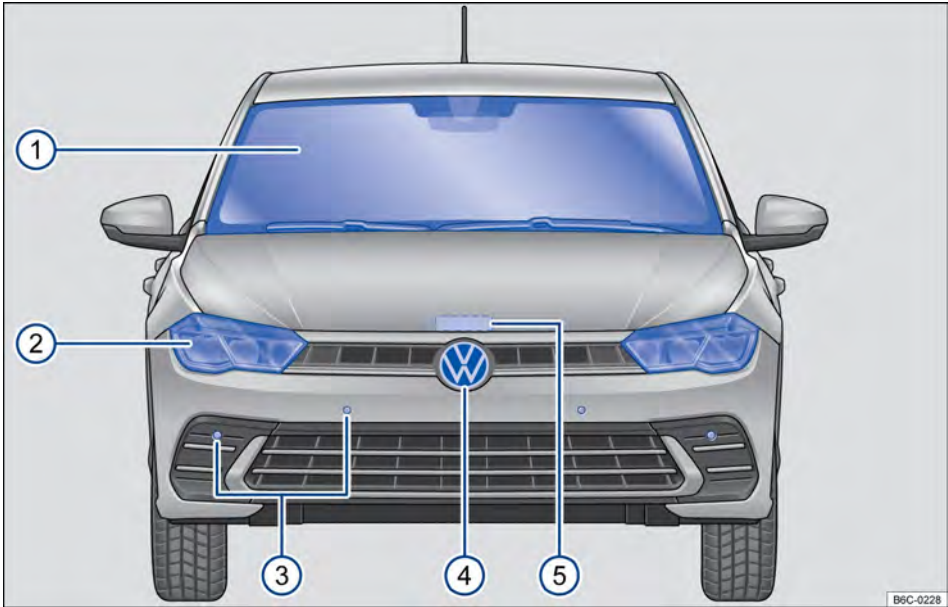

Fig. 2 Front view of the vehicle.

Key for → Fig. 2:

① Windscreen	
– Windscreen wipers.....	86
– Rain and light sensor in the region of the interior mirror.....	87
② Headlights.....	79, 197
③ Front Park Distance Control sensors.....	122
④ Behind the VW logo: radar sensor of assist systems	
⑤ Bonnet release lever.....	215

Bumper cover

Depending on the vehicle version, there may be a bumper cover that must not be removed. The cover does not have any purpose in Brazil. <

Side view

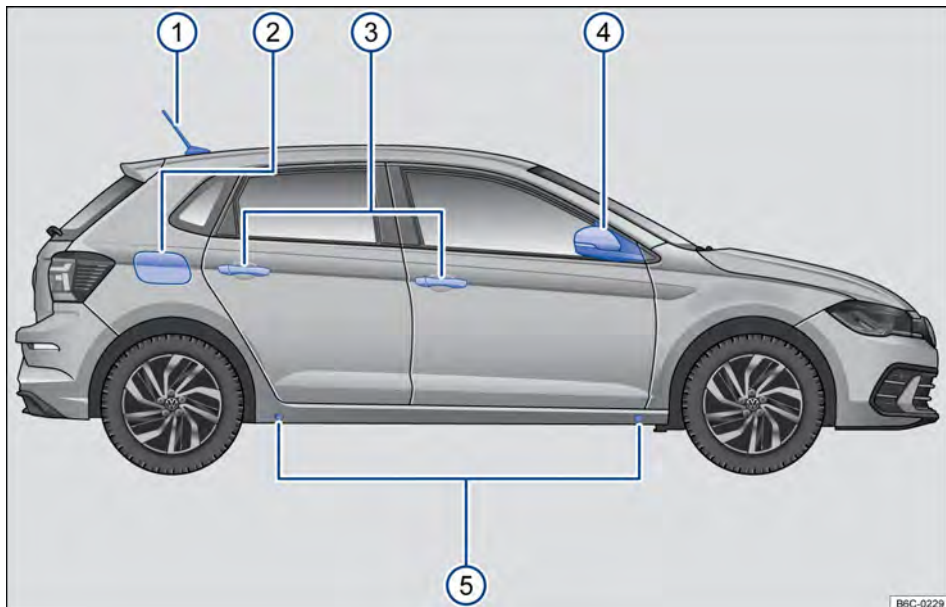

Fig. 3 Side view of the vehicle.

Key for→ Fig. 3:

① Roof aerial.....	265
② Tank flap.....	191
③ Exterior door handles.....	63
④ Exterior mirrors.....	88
⑤ Jacking points.....	247

Rear view

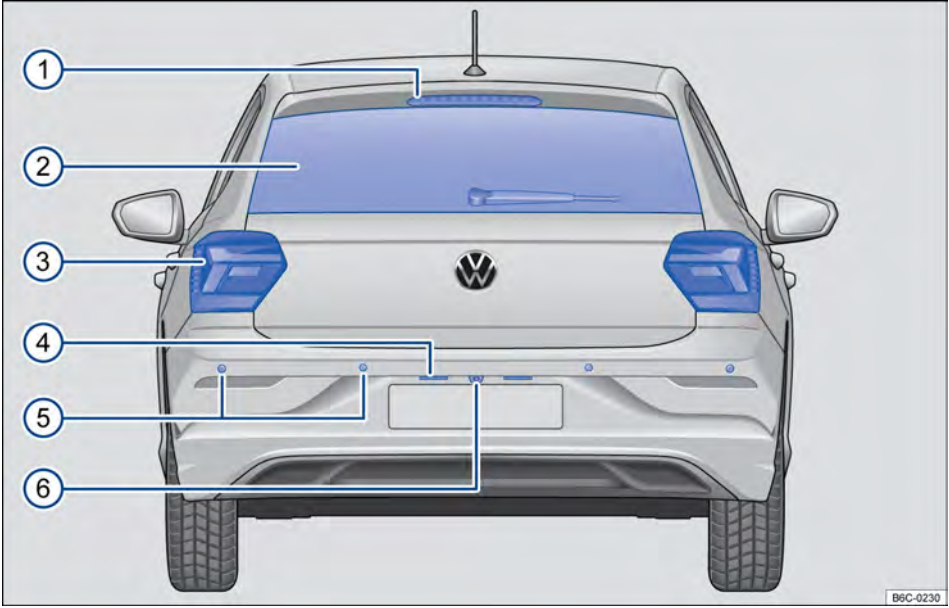

Fig. 4 Rear view of the vehicle.

Key for→ Fig. 4:

①	High-mounted brake light	
②	Rear window	
	– Rear window heating switch	92
	– Rear window wiper	86
③	Tail lights	79, 197
④	Rear number plate lights	197
⑤	Rear Park Distance Control sensors	122
⑥	Rearview camera system	125

Driver door

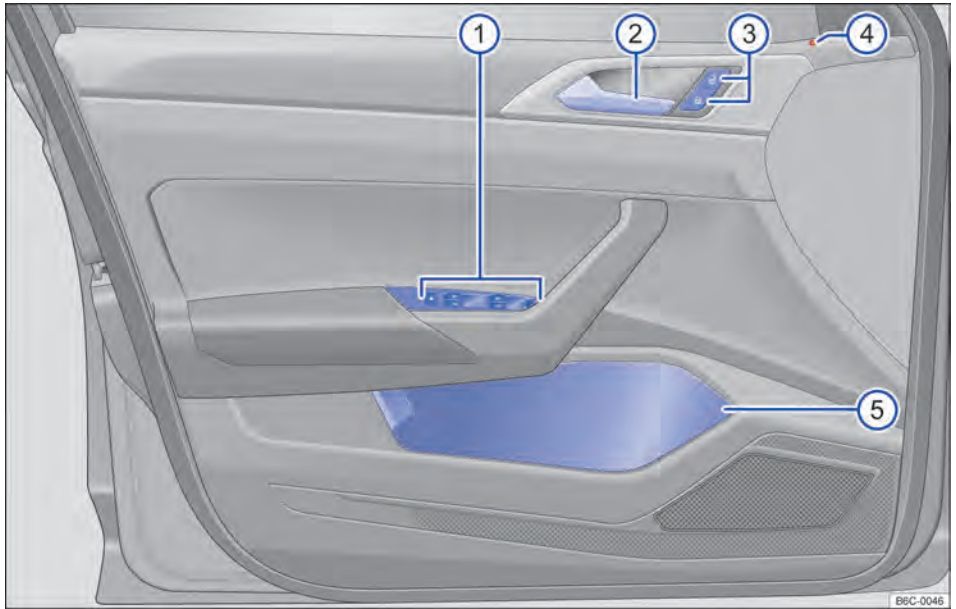

Fig. 5 Overview of the controls in the driver door.

Key for→ Fig. 5:

① Region for:	
– Setting rotary control for electric exterior mirrors.....	88
– Buttons for operating electric windows.....	71
② Interior door handle.....	63
③ Central locking button for locking and unlocking the vehicle.....	63
④ Central locking indicator lamp.....	64
⑤ Storage compartment.....	130

Driver's side

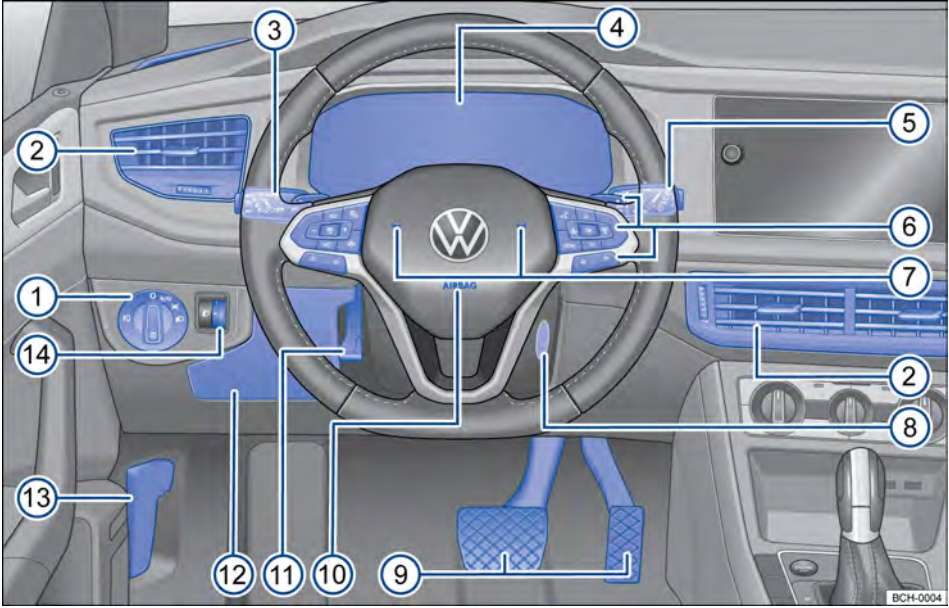

Fig. 6 Overview of the driver side.

Key for → Fig. 6:

① Light switch	79
② Air vents	92
③ turn signal and main beam lever	79
④ Instrument cluster	15
– with warning and indicator lamps	13
⑤ Lever for window wipers and washers	86
– with buttons to operate the TRIP, OK/RESET menus	27
⑥ Multifunction steering wheel controls:	
– Tiptronic paddles	112
– Audio $\llbracket \triangleright$	
– Cooperate the driver assistance systems RES, SET , Ⓢ , Ⓣ , - CNCL + or - CNL +	118
– Volume controls ⏮ , ⏭ , 🔊	
– Operate menu selection	
⏏ OK , ⏴ , ⏵ , VIEW (depending on vehicle version without function)	28
– Voice command activation 🗣 (no function)	
– Access the phone menu or answer a phone call 📞 (depending on the vehicle and radio version, this key has no function or phone calls can only be answered via the radio)	
⑦ Horn (works only when the ignition is switched on)	
⑧ Ignition lock	104
⑨ Pedals	97
⑩ Driver front airbag installation location	46 ▶

⑪ Steering column adjustment lever.....	73
⑫ Fuse box access cover.....	204
⑬ Bonnet release lever.....	215
⑭ Headlight range control switch.....	84 ◀

Centre console

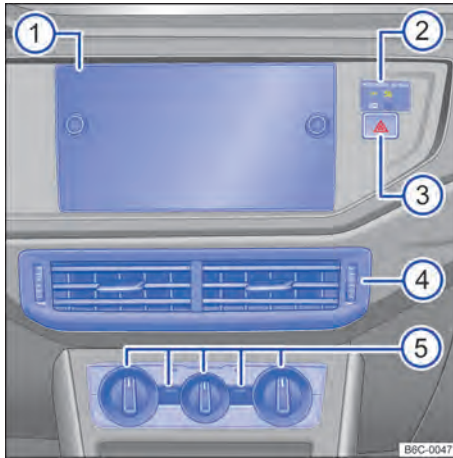

Fig. 7 Overview of the upper section of the centre console.

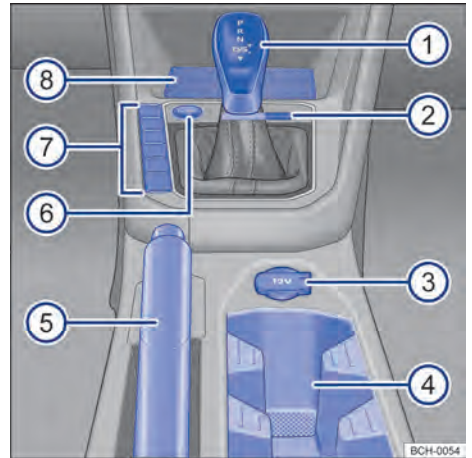

Fig. 8 Overview of the lower section of the centre console.

Key for→ Fig. 7:

① Radio system.....	137
② Front passenger front airbag deactivated indicator lamp OFF	43
③ Hazard warning lights button	58
④ Air vents.....	92
– According to the version of the vehicle, there may exist air vents for the rear seat passengers.	
⑤ Climatronic or air conditioning operating controls.....	92

Key for→ Fig. 8:

① Lever for:	
– Manual gearbox.....	110
– Automatic gearbox.....	111
② Card holder.....	130
③ 12-volt socket.....	136
④ Stowage compartment with drink holder on the centre console.....	134
⑤ Handbrake lever.....	121
⑥ Engine starter button (Press & Drive).....	104 ▶

⑦	Depending on the vehicle's version, button for:	
	– Start-Stop system.....	108
	– driving mode selection.....	117
	– park distance control (PWS).....	122
	– boot lid opening.....	69
⑧	Storage compartment	
	– with Qi wireless charging function.....	131

Front passenger side

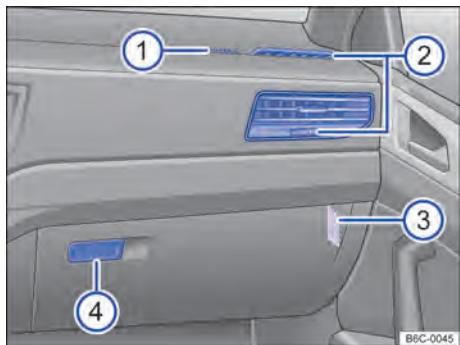



Fig. 9 Overview of the front passenger side.

Key for → Fig. 9:



①	Location of front passenger front airbag in the dashboard.....	42
②	Air vents.....	92
③	Key-operated switch to turn off the front passenger front airbag (if equipped).....	47
④	Opening lever for the stowage compartment.....	130

Symbols in the roof headliner

Symbol	Definition
 OFF, 	Interior and reading lights switch buttons → page 79.

Driver's information















Warning lamps and indicator lamps



















Warning and indicator lamps indicate a number of warnings → , faults →  or other specific functions. Some warning and indicator lamps light up when the ignition is switched on and should go out once the engine is running or the vehicle is in motion.





















Depending on the version, additional text messages could appear in the display on the instrument cluster to provide further information or to ask you to perform certain tasks → page 14.



Depending on the vehicle equipment level, symbols may be displayed in the instrument cluster instead of warning lamps.

Sound signals can also be heard when certain warning or indicator lamps light up.

Symbol	Meaning → 
	Central warning lamp. Observe the additional information displayed on the instrument cluster.
	 Stop driving! Parking brake engaged. → page 121
	 Stop driving! Brake fluid level too low or faulty brake system. → page 224
	 Stop driving! Coolant temperature too high or engine coolant level too low. → page 222
	 Stop driving! Engine oil pressure too low. → page 218
	Flashing:  Stop driving! Steering damaged. → page 116
	On: electromechanical steering not working. → page 116
	Driver or front passenger seat belt not fastened. → page 34

Symbol	Meaning → 
	Fault in the alternator. → page 226
	Central warning lamp. Observe the additional information displayed on the instrument cluster.
	Lit: ESC damaged or switched off by the system. → page 127
	Flashing: ESC or TCS enabled and running. → page 127
	Traction control (TCS) manually disabled. → page 127
	ABS faulty or not functioning. → page 127
	Driving illumination partially or totally out of order. → page 197
	Fault in pollutant emission control system. → page 192
	Cold start system heating (TOTAL-FLEX engine). → page 226
	Fault in electronic engine output control. → page 192
	Reduced electromechanical steering. → page 116
	Tyre pressure to low or damaged tyre pressure control system. → page 231
	Fuel tank almost empty. → page 18
	On: Engine oil level very low. → page 218
	Flashing: engine oil system damaged. → page 218
	Fault in front belt tensioner system or airbag. → page 42
	Manual gearbox: excessive clutch temperature or damaged clutch. → page 110

Symbol	Meaning → 
	Automatic gearbox: damage in the automatic gearbox. → page 111
	Left or right turn signals. → page 79
	Hazard warning lights switched on. → page 58
	Emergency brake activation lights. → page 58
	On: Step on the brake pedal! (start the engine). → page 111
	Flashing: the interlock button of the selector lever is not engaged. → page 114
	Cruise control system (GRA) on. → page 118
	Main beam is switched on or the headlight flasher is being operated. → page 79
	Manual gearbox: the clutch does not transmit the total torque of the engine. → page 110
	Start-Stop system enabled. → page 108
	Start-Stop system not available. → page 108
	Eco driving mode. → page 117
	Normal driving mode. → page 117
	Sport driving mode. → page 117
	Individual driving mode. → page 117
	Service reminder or service about to become due. → page 26
	Charge status of the connected mobile phone battery. Only when activated by the factory-fitted mobile phone interface → page 137.
	Outside temperature below +4° C. → page 20
	Cruise control system on. → page 118

Symbol	Meaning → 
	Cruise control system (GRA) damaged. → page 118
	Instructions regarding vehicle wallet information.

WARNING

Failure to observe the warning lamps could lead to your vehicle breaking down in traffic, and to accidents and serious injuries.

- Never ignore any warning lamps or text messages that appear.
- Stop the vehicle as soon as possible and when safe to do so.
- Stop the vehicle at a safe distance away from moving traffic and ensure that no part of the exhaust system can come into contact with any inflammable material underneath the vehicle, e.g. dry grass, fuel or oil, etc.
- Broken-down vehicles lacking due signalling increase the risk of accidents both for you and for other road users. Always switch on the hazard warning lights and set up the warning triangle to warn other road users.
- Before opening the engine compartment cover, switch off the engine and allow it to cool down sufficiently.
- The engine compartment of any motor vehicle is a dangerous area and may cause severe injuries → page 213, *Safety guidelines for work in the engine compartment.*

NOTICE

Failure to observe the illuminated indicator lamps could lead to vehicle damages. ◀

Instrument cluster

Introduction

According to its version, the vehicle may be equipped with an analogue or digital instrument cluster (Active Info Display) version 1 or version 2. ▶

After starting the engine with the vehicle's battery completely flat, or with a replacement battery in the vehicle, the system's configuration (time, date, comfort and programming configurations) may have been deleted or become corrupted. Check and adjust the settings after the vehicle battery has been sufficiently recharged.

⚠ WARNING

Accidents and injuries can occur if the driver is distracted.

- Never operate the instrument cluster's buttons while the vehicle is in motion.
- To prevent the risk of accidents and injuries proceed with all the settings of the indicators of the instrument cluster's display and those of the radio system's display only when the vehicle is stopped.

Analogue instrument cluster

📖 Please refer to **▲** at the start of the chapter on page 15.

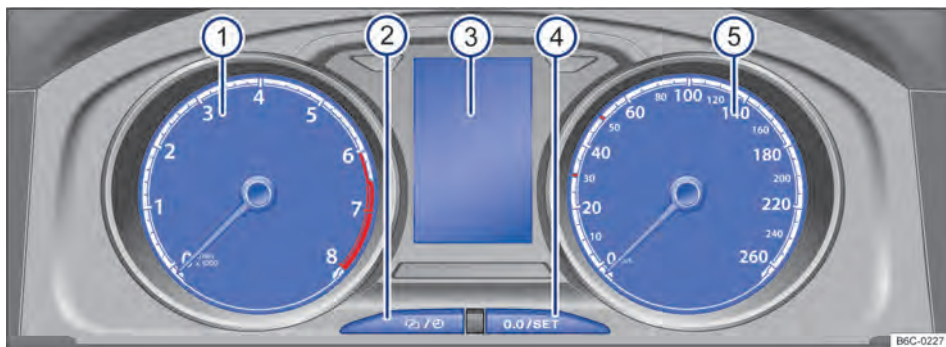



Fig. 10 Analogue instrument cluster.

Some of the controls and functions depicted are specific to certain models/versions or are optional.

Explanations to the instruments → **Fig. 10**:

- ① **Rev. counter** (running engine speed in revolutions x 1.000 per minute) → page 18.
- ② **Clock setting knob**¹⁾  → page 25.
- ③ **Display indicators** → page 20.
 - Fuel level display → page 18.

- ④ **Reset button** or to display the (trip) recorder.
 - Press the  button for *about 2 seconds* to reset the trip recorder.
- ⑤ **Speedometer** (speed indicator).

⚠ NOTICE

Some segments may remain lit after switching on the ignition, with no effect on its operation.

¹⁾ According to the vehicle's version, the clock can also be set through the configurations menu of the radio display.

Digital instrument cluster (Active Info Display) - version 1

📖 Please refer to ⚠ at the start of the chapter on page 15.

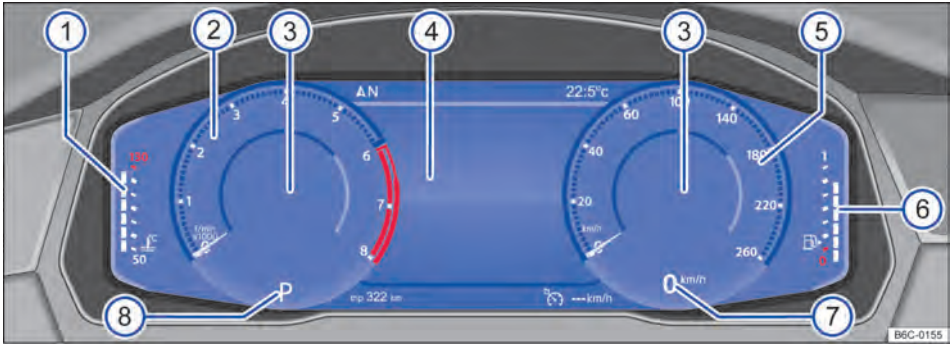

Fig. 11 Active Info Display (version 1) on the dash panel.

The Active Info Display is a digital instrument cluster with a high resolution colour TFT display. Through the selection of different information profiles other round classic instruments can be displayed, such as rev counter or speedometer.

According to the vehicle version, the digital instrument cluster and the trip data display functions may not be available.

Explanations to the instruments → Fig. 11:

- ① **Engine temperature indication** → page 19.
- ② **Rev. counter** (running engine speed in revolutions x 1.000 per minute) → page 18.
- ③ **Information profile indicator**. The displayed content varies according to the selected information profile.
- ④ **Display indicators** → page 20.
- ⑤ **Speedometer** (speed indicator).
- ⑥ **Fuel gauge** → page 18.
- ⑦ **Digital speed display**.
- ⑧ **Currently engaged gear or selector lever position** → page 111.

Information profiles

Depending on the vehicle version, the radio may not be available.

According to the radio version and the selected information profile, additional information is shown at the centre of the round instruments → Fig. 11 ③ of the Active Info Display.

Variant 1 - different topic-specific information profiles can be selected by way of the radio button , on the function selection pad , select **Active Info Display**. The following information profiles can be selected:

- **Classic**: without additional displays.
- **Consumption & Fuel range**: digital display of average consumption and graphic display of the current fuel consumption in the centre of the rev counter. Digital fuel range display in the centre of the speedometer.
- **Efficiency**: digital display of average consumption and graphic display of the current fuel consumption in the centre of the rev counter.
- **Driver assist system**: graphic representation of different driver assist systems or digital travel time display in the centre of the rev counter. Arrow navigation or compass display in the centre of the speedometer.

Digital instrument cluster (Active Info Display) - version 2

📖 Please refer to ▲ at the start of the chapter on page 15.

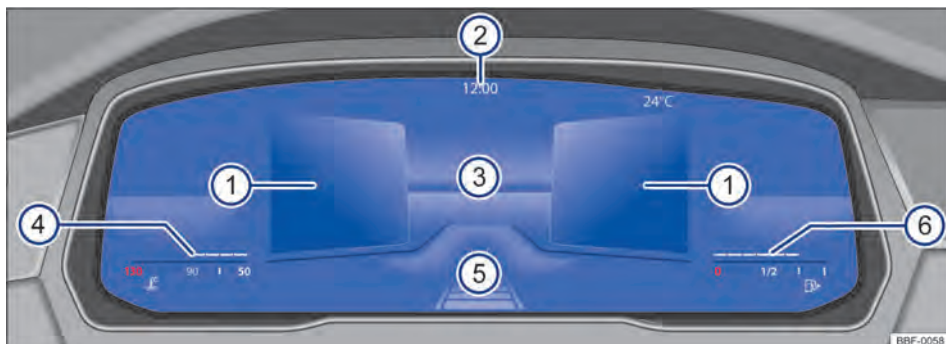

Fig. 12 Active Info Display (version 2) on the dash panel.

The Active Info Display is a digital instrument cluster with a high resolution colour TFT display. Additional content may be displayed by selecting different profiles and indicators.

Depending on the vehicle version and country, the digital instrument cluster and the trip data display functions may not be available.

Explanations to the instruments → Fig. 12:

- ① Information profile indicator.
- ② Time and temperature.
- ③ Main display area.
- ④ Currently engaged gear or selector lever position.
- ⑤ Driver assistance enabled..
- ⑥ Range.

Main indicator

Depending on the vehicle version, the information available in the cluster may not be available.

The main display → Fig. 12③ can be switched by pressing **[View]** on the multifunction steering wheel. The representation in the display area can show the following views:

- **Summary:** after completing the readiness check: displays information on vehicle status in areas ①, such as current mileage.
- **Digital view:** digital speedometer with information profiles.
- **Speed:** classic speedometer representation as a round gauge.
- **Rev. counter:** classic rev. counter representation as a round gauge.

Information profiles





The information profiles ① can be configured or hidden separately from each other. Multiple data can be displayed on driving, navigation warnings or information regarding audio playback or the phone interface.

Selecting driving profiles:



- In the multifunction steering wheel, press **[⏪]** or **[⏩]** to select the right or left information profile area.
- Use the arrow buttons **[▲]** or **[▼]** to select the desired information profile.
- Press **[OK]** to confirm the selection.

Selecting driving profiles in the round gauge:

- To select a driving profile in the main display ③ with view adjusted to round gauge, proceed as follows:
- Use the arrow buttons **[▲]** or **[▼]** to select the desired information profile.
- Press **[OK]** to confirm the selection.

 Depending on the vehicle and radio version, to make a phone call and if the first position in the calls list is not accessible, use the arrow buttons  or  to navigate and the button  to make the call. 

Tachometer (Rev counter)



 Please refer to  at the start of the chapter on page 15.

The tachometer may differ depending on the vehicle version or may not be available.

The start of the red zone on the rev counter indicates the maximum engine speed of a run and warm engine for each selected gear. Change to the next higher gear, position the selector lever to **D/S** or relieve the accelerator pedal before the needle reaches the red zone → .

NOTICE

- While the engine is cool, avoid high rotations, total acceleration and increased engine load.
- To avoid engine damages, the rev. counter needle must not remain in the red area of the scale for more than a short period of time.

 Switching to higher gears in advance helps save fuel and reduce operating noises. 

Fuel gauge



 Please refer to  at the start of the chapter on page 15.



Fig. 13 In the analogue instrument cluster: fuel gauge.

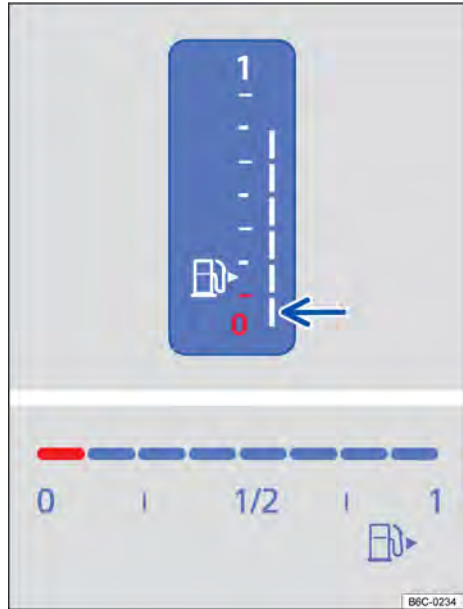



Fig. 14 In the digital instrument cluster: fuel gauge.

The fuel gauge may vary depending on the vehicle model → [Fig. 13](#) or → [Fig. 14](#).

Fuel tank almost empty

The yellow indicator lamp must light up. The reserve fuel (red mark) will be consumed → .

- Fill the tank as soon as possible → .

When switching the ignition on, certain warning and indicator lamps flash to check functions. Such lamps go out after a few seconds.

WARNING

Driving the vehicle when the fuel level is too low could lead to your vehicle breaking down in traffic, accidents and serious injuries.

- When the fuel level is too low, the fuel supply to the engine could be irregular, especially when driving up or down hills and inclines. 



- The steering, all driver assist systems and brake assist systems will not function if the engine stops due to a lack of fuel or irregular fuel supply.
- Always fill the tank when it is still 1/4 full. This reduces the risk of running out of fuel and breaking down.

NOTICE

Do not run the tank completely empty. Irregular filling periods can cause backfiring and allow unburnt fuel to enter the exhaust system. This could damage the catalytic converter!

 The small arrow next to the fuel pump symbol → Fig. 13 or → Fig. 14 in the display instrument indicates the side of the vehicle on which the tank flap is located.

Engine coolant temperature indicator

 Please refer to  at the start of the chapter on page 15.

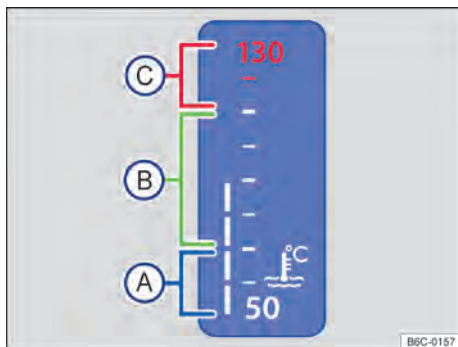

Fig. 15 Engine coolant temperature indicator in the digital instrument cluster (version 1): (A) cold zone; (B) normal zone; (C) warning zone.



Fig. 16 Engine coolant temperature indicator in the digital instrument cluster (version 2): (A) cold zone; (B) normal zone; (C) warning zone.

The engine coolant temperature gauge may differ depending on the vehicle version or may not be available.

- (A) **Cold zone.** The engine has not yet reached its operating temperature. Avoid engine overloading and high rotation while the engine is cooled.
- (B) **Normal zone.**
- (C) **Warning zone.** Coolant temperature too high.

and Engine coolant

The red centre warning lamp is on. In addition a text message is displayed on the instrument cluster display.

The engine coolant level is not correct or the coolant system is faulty.

Engine coolant

For vehicles with an analogue combined instrument panel, the control light flashes red.

The engine coolant level is not correct or the coolant system is faulty.

and Engine coolant

The red centre warning lamp is on. In addition a text message is displayed on the instrument cluster display.

The engine coolant level is not correct or the coolant system is faulty.

Stop driving!

- Stop the vehicle, turn the engine off and let it cool down.
- Check coolant level, if the level is low, refill with engine coolant → page 223.
- If the warning lamp remains lit despite the coolant level being correct, then there is a fault in the system. Contact a Volkswagen Dealership.

Display indicators - analogue and digital (version 1)

📖 Please refer to ⚠ at the start of the chapter on page 15.

On the dash panel insert display several different pieces of information may be displayed according to the version of the vehicle:

- Doors, bonnet and boot lid open
- Warning and information displays → page 23
- Distance displays
- Time
- Exterior temperature
- Selector lever positions (automatic gearbox) → page 111
- Gear recommendation → page 98
- Driving data indicator (multifunction display) and menus for several settings → page 27
- Service interval display → page 26
- Start-Stop system status indicator → page 108
- Engine code

Doors, bonnet and boot lid open

After unlocking the vehicle and during driving, the open doors as well as an open bonnet or an open boot lid are indicated on the display of the instrument cluster as well as announced by sound alarms. The screen may vary according to the version of the fitted instrument cluster.

Distance displays

The *odometer* records the total distance travelled by the car.

The *trip recorder* (trip) shows the distance travelled since the trip recorder was last reset. The last digit stands for 100 m.

- *Vehicles with analogue instrument cluster:* briefly press the **0.0/SET** button on the instrument cluster → page 15 to reset the trip recorder to 0.
- *Vehicles with a digital instrument cluster:* use the arrows on the multifunction steering wheel **⬆** or **⬇**, go to **Trip data** menu, select the **trip** indicator and briefly press the **OK** button on the multifunction steering wheel.

Exterior temperature indicator

Whenever the exterior temperature is below +4°C, a "snowflake symbol" ❄ appears on the exterior temperature indicator (ice on the road). This symbol remains lit until the outside temperature rises above +6 °C → ⚠.

If the vehicle is parked or moving at a very low speed, the indicated temperature may be slightly higher than the actual exterior temperature, due to the heat generated by the engine.

The measurement range is -40°C to +50°C.

Selector lever positions (automatic gearbox)

The gear selected is displayed on the side of the selector lever and on the display in the instrument cluster. With the selector lever in **D/S** position as well as with Tiptronic, the respective selected gear may be indicated, if the case, on the instrument cluster → page 111.

Gear-change indicator

Depending on the vehicle version, a gear selection recommendation may be indicated on the instrument cluster display to optimize fuel savings → page 98.

Radio

In some versions, certain radio functions are indicated on the instrument cluster display only while the vehicle is running.

Engine code

Vehicles with analogue instrument cluster.

- Turn the ignition on without starting the engine.
- Press and hold the **0.0/SET** button on the instrument cluster pressed for about fifteen seconds for the engine identification letters to be displayed.

Vehicles with digital instrument cluster.



- Turn the ignition on without starting the engine.
- On the instrument cluster **Trip data** menu, select the **Fuel range** display.
- Hold the **OK** button on the multifunction steering wheel pressed for about five seconds, upon release, the **Services** menu will be displayed → page 25.
- Go to the **Engine code** menu item.

WARNING

There may be ice layers on roads and bridges even if the exterior temperature is above freezing temperature.

- There may be ice layers on roads even if the exterior temperature is above +4°C and the "snowflake symbol" is not indicated on the display.
- Never consider only the exterior temperature indicator!

Display indicators - digital (version 2)

 **Please refer to  at the start of the chapter on page 15.**

On the dash panel insert display several different pieces of information may be displayed according to the version of the vehicle:

- Doors, bonnet and boot lid open
- Warning and information displays → page 23
- digital
- Date and Time
- Radio displays
- Exterior temperature
- Selector lever positions (automatic gearbox) → page 111
- Gear recommendation → page 98
- Service interval display → page 26
- Low-power driving status
- Engine code
- Driver assist system display
- Cooling fan return display
- Driving data indicator (multifunction display) and menus for several settings → page 27

- Engine oil temperature
- Phone guidance

Doors, bonnet and boot lid open

After unlocking the vehicle and during driving, the open doors as well as an open bonnet or an open boot lid are indicated on the display of the instrument cluster as well as announced by sound alarms. The screen may vary according to the version of the fitted instrument cluster.

Automatic gearbox selector lever positions

The gear selected is displayed on the side of the selector lever and on the display in the instrument cluster. The gearshift pattern is shown when pressing the brakes or the selector lever on the instrument cluster → page 111.

Exterior temperature indicator

Whenever the exterior temperature is below +4°C, a "snowflake symbol" ❄ appears on the exterior temperature indicator (ice on the road).

This symbol remains lit until the outside temperature rises above +6 °C → .

If the vehicle is parked or moving at a very low speed, the indicated temperature may be slightly higher than the actual exterior temperature, due to the heat generated by the engine.

The measurement range is -45 °C to +76 °C.

Gear-change indicator

Depending on the vehicle version, a gear selection recommendation may be indicated on the instrument cluster display to optimize fuel savings → page 98.

Fuel saving driving status

While driving, the instrument cluster display shows the vehicle's fuel saving driving status .

Engine code

- Open the **Service** → page 25 menu.
- Go to the **Engine code** menu item.

Radiator fan return display

This display is shown after completing the driving readiness check and if the radiator fan is in return. ▶

Subsequent radiator fan operation time may be conditioned by:



- Active brake cooling after downhill driving.
- Engine heat dissipation after high load (e.g. towing a trailer).

WARNING

There may be ice layers on roads and bridges even if the exterior temperature is above freezing temperature.



- There may be ice layers on roads even if the exterior temperature is above +4°C and the “snowflake symbol” is not indicated on the display.
- Never consider only the exterior temperature indicator!

Travel data display (multifunction display)

 Please refer to  at the start of the chapter on page 15.

The travel data indicator (multifunction display) displays the several different driving and consumption data and is equipped with 3 memories.

Switching between displays

- *Vehicles without multifunction steering wheel:* press the  switch on the windscreen wiper lever → page 27.
- *Vehicles with multifunction steering wheel:* press the  or  button → page 28.

Toggle between the memories

With the ignition turned on and the memory displayed, press the  button on the wiper lever or the  button on the multifunction steering wheel.

Memory “As of travel start”

Display and storage of the driving and consumption data collected from turning the ignition on to turning it off. When driving is interrupted for over 2 hours, the memory is automatically deleted after resuming driving.



Memory “As of fuelling up”

Display and storage of the collected driving and consumption data. The memory is deleted after fuelling up and the vehicle starts moving.



“Long-term” Memory

The memory collects the driving data for up to 19 hours and 59 minutes or 99 hours and 59 minutes of travel time or 1999.9 km or 9999.9 km of driven distance. When one of these maximum marks¹⁾ is surpassed, the memory is deleted.

Manually deleting the travel data memory

- Select the memory that you wish to delete.
- Press and hold  in the window wiper lever or  in the multifunction steering wheel for approximately two seconds.

Selecting indicators

According to the vehicle and radio version, the possible trip data indicators to be displayed on the instrument cluster can be set in the radio system by way of the  button **OR** through the settings button . Simply touch the function button  → page 28.

Indicator “Fuel range”

The estimated distance in km that may be travelled with the amount of fuel in the tank, under the current driving style.

“Average consumption” Indicator

The average consumption in km/l is shown after a distance of 300 meters, after switching on the ignition. The display will show dashes up to this point. Displayed values are updated every 5 seconds.

“Consumption” Indicator

The current fuel consumption is displayed in km/l when the vehicle is motion with running engine. The current value is calculated in 30 meter intervals and updated approximately every second.

“Oil temperature” Indicator

The engine oil temperature display may not be available on the instrument cluster display according to the vehicle version.

Current engine oil temperature as digital indicator. 

¹⁾ According to the instrument cluster version.

“Warning at --- km/h” Indicator

For analogue instrument cluster:

If the set speed (within the range of 30 km/h (18 mph) and 150 km/h (93 mph)) is exceeded, acoustic and visual warnings will be given.

Digital speed indicator

Current vehicle speed displayed digitally.

“Average speed” Indicator

The average speed will be shown after a distance of 300 meters travelled since the ignition was switched on. The display will show dashes up to this point. Displayed values are updated every 5 seconds.

“Distance covered” Indicator

Distance travelled in km since the ignition was switched on.

“Travel time” Indicator

Travel time in hours (h) and minutes (min) elapsed since the ignition was switched on.

Saving a speed alarm speed

For analogue instrument cluster:

- Warning at --- km/h indicator selection.
- Press the **OK/RESET** button on the wiper lever or the **OK** button on the multifunction steering wheel to save the current speed and to activate the warning.
- Set the desired speed within 5 seconds using the **TRIP** button on the wiper lever or the **Δ** or **▽** buttons on the multifunction steering wheel. Press the **OK/RESET** or **OK** button again or wait a few seconds. The speed is saved and the warning activated.
- To deactivate, press the **OK/RESET** or the **OK** button again. The saved speed is deleted.

(→ page 13), and, if required, also by acoustic alarms. The display of the icons and texts may vary according to the fitted instrument cluster.

Existing functional faults can also be accessed manually. To do so, access the **Vehicle status** menu → page 27.

Priority 1 warning message

The red central warning lamp blinks or is on - partly in association with warning buzzers or additional symbols.  **Stop driving!** Dangerous situation. Check the damaged function and eliminate its cause. Seek assistance from a Volkswagen Dealership, if necessary.

Priority 2 warning message

The yellow central warning lamp blinks or is on - partly in association with warning buzzers or additional symbols. Faulty functions or lack of fluids may damage or interrupt vehicle operation. Check the faulty function as soon as possible. Seek assistance from a Volkswagen Dealership, if necessary.

Guidance on information in the owner's manual

Further guidance on the current warning message can be found in the owner's manual.



Information text.

Information about various procedures within the vehicle.

 According to the version some adjustments and displays may be made/seen on the radio system.

 When there are several warnings, the icons will be displayed in sequence a few seconds each. The symbols will appear until the faults are rectified.

Warning and information texts

 Please refer to  at the start of the chapter on page 15.

The system runs a check on certain components and functions in the vehicle when the ignition is switched on or while the vehicle is in motion. Function faults are indicated by red and yellow warning symbols with warning and information text messages on the instrument cluster display

Driver alert system (interval recommendation)

📖 Please refer to ⚠️ at the start of the chapter on page 15.



Fig. 17 On the instrument cluster display: driver alert system icon.

The driver alert system warns the driver when his driving attitude indicates tiredness.

Depending on the vehicle version, the driver alert system indicator may not be available.

Function and operation

The driver alert system warns the driver when his driving attitude indicates tiredness.

The driver alert system senses the driving behaviour at the beginning of a trip and from this derives possible weariness indications. This is constantly compared to the actual driving behaviour. Should the system detect signs of fatigue of the driver, it sounds a “gong” alarm and displays a visual warning with an icon → Fig. 17 on the display of the instrument cluster together with a supplementary text message. The text message on the instrument cluster display is displayed for about 5 seconds and, if necessary, is repeated once. The last message is saved by the system.

The message on the instrument cluster display can be turned off by pressing the **OK/RESET** button on the wipers lever or the **OK** button on the multifunction steering wheel → page 27. The message on the instrument cluster display may be accessed again through the multifunction indicator → page 23.

Operating conditions

Driving behaviour is only assessed at speeds between 60km/h and approximately 200km/h.

Turning on and off

Depending on the vehicle and radio version, the Driver Alert System can be activated or deactivated through the radio system with the button **CAR** OR by through the settings button **+**. Simply touch the function button **Car** → page 28.

Operating limitations

The alertness detection system has system limitations. The following conditions may cause the alertness detection system to operate only in a limited way or not to operate altogether:

- Speeds below 60 km/h.
- Speeds above 200 km/h.
- Curvy stretches.
- Roads in poor condition.
- Unfavourable climate conditions.
- When the driver is too inattentive.

Under the following conditions the driver alert system gets reset:

- Ignition is turned off.
- Driver's safety belt is loose and the driver door is open.
- The vehicle is standing still for over 15 minutes.

When driving over a longer period at low speed (less than 60 km/h), the assessment is automatically reset by the system. When driving faster later on, the driving behaviour is recalculated.

⚠️ WARNING



The intelligent alertness detection technology is not able to overcome physical limitations and operates only within the limitations of the system. The higher level of convenience provided by the alertness detection system should not encourage the driver to take risks. When driving over longer distances take regular and long enough breaks.

- The driver is ultimately always responsible for his driving capacity.
- Never drive a vehicle when tired.
- The system does not recognize a low level of alertness under all circumstances. Observe the information provided in section “Operational limitations” → page 24.





- In some situations the system may incorrectly interpret an intentional driving manoeuvre for lack of alertness from the driver and an indication for weariness.
- No critical alarm is sounded for the so called “microsleep (napping at the steering wheel)” episodes!
- Pay attention to the indications on the instrument cluster display and follow the corresponding instructions.

 The alertness detection system was solely developed for driving on highways and well paved roads.



 In case of malfunction, seek assistance from a Volkswagen Dealership.

- Briefly press  to set the minutes. Numbers are displayed in ascending order. Keep the  button pressed to run fast forward.
- Press the  button again to conclude the clock setting.

Time setting by way of the digital instrument cluster (Active Info Display)





- On the menu Trip data, select the Range display.
- Keep the  button on the multifunction steering wheel pressed for about five seconds, upon release, the services menu will be displayed on the digital instrument cluster display → page 25.
- Select the Time menu.
- Set the time with the arrow buttons  or .  

Time





 Please refer to  at the start of the chapter on page 15.

Time setting by way of the radio system



Depends on the radio and vehicle version.

- Press the radio  button.
- Touch the function button  to open the Vehicle Settings menu.
- Select the menu item Date and time to set the time → page 28.
- **OR**
- Press the settings button .
- Touch the  function button to open the menu.
- Select the menu item Date and time to set the time → page 28.

Time setting by way of the analogue instrument cluster

- Switch on the ignition.
- To adjust the clock, press the  button on the instrument cluster → page 15 to select the hour indicator.
- Briefly press button  to set the hour. Numbers are displayed in ascending order. Keep the  button pressed to run fast forward.
- Briefly press the  button to select the minutes indicator.

Services Menu





 Please refer to  at the start of the chapter on page 15.

Depending on the vehicle version, settings may be configured using the Service menu of the digital instrument cluster (Active Info Display).

Open the Service menu in the digital instrument cluster (version 1)

On the Journey data menu of the instrument cluster select the Range indicator and keep the  button on the multifunction steering wheel pressed for about five seconds, upon release the Service menu is displayed. Browse through the menu using the multifunction steering wheel buttons.

Open the Service menu in the digital instrument cluster (version 2)

Access the Travel type/trip information profile. On the Travel type/trip, press and hold  or  on the multifunction steering wheel in the same direction for 6 seconds. Browse through the menu using the arrow buttons  and .

Reset the service interval display

Select the Service menu and follow the instructions on the digital instrument cluster display. 

Reset the oil change service

Select the **Reset oil service** menu and follow the instructions on the digital instrument cluster display.

Reset the inspection service

Select the **Reset inspection** menu and follow the instructions on the digital instrument cluster display.

Reset the trip recorder

To reset the trip recorder, select the **Reset trip** menu and follow the instructions on the digital instrument cluster display.

Engine code

Select the **Engine code** menu. The engine code is displayed on the digital instrument cluster display.



Set the time

Select the **Time** menu and set the correct time with the arrow buttons Δ or ∇ .

Copyrights

Select the **Copyright** menu to access copyright information.

Service interval display

 Please refer to  at the start of the chapter on page 15.

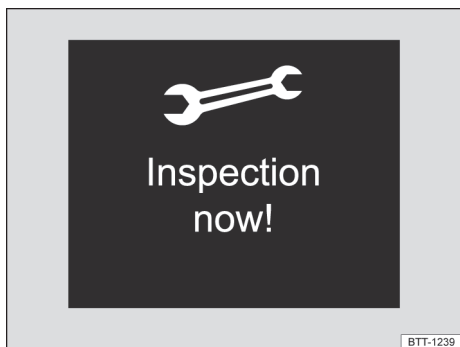

Fig. 18 On the instrument cluster display: indication example of a service event soon to become due (schematic representation).

The service interval indicators show on the instrument cluster display → Fig. 18 or on the radio system display.

There being different instrument cluster and radio system versions available, display indications may vary.

Service warning

When a service is becoming due, a service warning is displayed when turning the ignition on.

The mileage or specified interval time correspond to the mileage or interval until the next service.



Service reminder

When a **service is about to become due** a warning is sounded and, for a brief instant, the wrench icon  may be displayed on the instrument cluster display along with other exhibits → Fig. 18.

Access the service deadline

With the ignition turned on and the vehicle stationary, it is possible to access the current service deadline.

 *Service deadline access via the radio system, depends on the vehicle and radio versions.*

- Press the radio **CAR** button.
- Touch the function button  to open the Vehicle Settings menu.
- Select the **Service** item on the menu to display the service information.
- **OR**
- Press the settings button .
- Touch the **Car** function button to open the menu.
- Select the **Service settings** item on the menu to view service information.

Vehicles with analogue instrument cluster.

- Press and hold the  button on the instrument cluster pressed until the word **Service** appears on the display.
- Release the button and wait for approximately two seconds or press the **0.0/SET** button. The current service interval is displayed.



Vehicles with Digital instrument cluster (Active Info Display).

- The interval can be consulted via the **Services** menu → page 25. 

Resetting the service interval display

If the service was not performed by a Volkswagen Dealership, the instrument cluster display can be reset as follows:





Vehicles with analogue instrument cluster.

- Switch off the ignition.
- On the instrument cluster, press and hold the  button.
- Turn the ignition on again.
- Release the  button.
- Confirm the request to restart the service on the instruments panel with the  button.

Vehicles with Digital instrument cluster (Active Info Display).

- The service interval display can only be reset via the **Service** menu → page 25.

Do not reset the display between service intervals. This may result in incorrect displays.

 The service message disappears after a few seconds with the engine running or after pressing the  or  button on the instrument cluster, or the  button on the multifunction steering wheel.

Dash panel insert operation

Introduction

Some menu options can only be called up when the vehicle is stationary.



In vehicles equipped with multifunction steering wheels, the window wiper lever buttons are absent. In these cases, the multifunction display is operated exclusively through the multifunction steering wheel buttons.

WARNING

Drivers distracted while driving could lead to accidents and injuries.

- Never access the instrument cluster menus while the vehicle is in motion.

Dash panel insert menus

 Please refer to  at the start of the chapter on page 27.

The scope of the menus and information indicators depends on the electronic components shipped with the vehicle and vehicle version scope.

Some menu options can only be called up when the vehicle is stationary.



Travel data → page 22

Audio → page 137

Phone → page 137

Vehicle status → page 27

Operation by way of the windshield wiper lever

 Please refer to  at the start of the chapter on page 27.

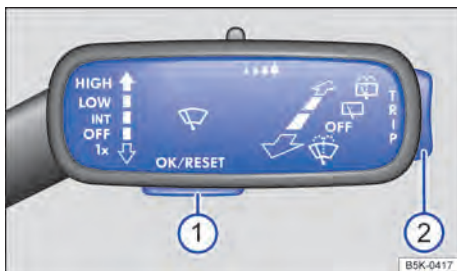





Fig. 19 Vehicles without multifunction steering wheel: press button  on the windows wiper lever to confirm the menu items and the rocker switch  to switch among the menus.

While a priority 1 warning message is displayed, it is not possible to call up any menu. All warning messages automatically disappear after a few seconds. In addition, certain warning messages can be confirmed and hidden with the  button.

Menu or information screen selection

- Switch on the ignition.
- If a message or the vehicle pictogram is shown, press the → **Fig. 19**  button, if necessary, press several times.

- To display the menus → page 27 or to return to the menu selection from a menu or from an information display, just keep the selector → Fig. 19 ② pressed.
- Press the selector up or down to scroll through the menu.
- To access the menu or the displayed information, press the → Fig. 19 ① button and wait a few seconds for the menu or the information display to open automatically.

Changing the menu settings

- In the menu, press the → Fig. 19 ② selector up or downward until the desired menu item is selected.
- Press the → Fig. 19 ① button to confirm the selected change. A “tick-off sign” indicates that the function or system is enabled.

Returning to the main menu

To exit the menu, select the **Return** item on the menu.

seconds. In addition, some warning messages can be confirmed and hidden using the **OK** button on the multifunction steering wheel.

Menu or information screen selection

- Switch on the ignition.
- When a message or the vehicle pictogram is displayed, press the **OK** → Fig. 20 button, case required press several times.
- To display and navigate the menu press the **☰** or **☷** → Fig. 20 button.
- To access the menu or the information display screen, press the **OK** → Fig. 20 button or wait a few seconds for the menu or the information screen to open on its own.

Changing the menu settings

- On the displayed menu use the arrow buttons **▲** or **▼** → Fig. 20 to select the desired item.
- Press **OK** → Fig. 20 to confirm the selected change. A “tick-off sign” indicates that the function or system is enabled.

Returning to the main menu

Press the **☰** button or select **Return** menu item.

i For vehicles without a radio, the controls for the multifunction steering wheel are deactivated. If an original Volkswagen radio is subsequently installed at a Volkswagen Dealership, it is possible to activate the controls on the multifunction steering wheel.

Operation by way of the multifunction steering wheel

📖 Please refer to **⚠** at the start of the chapter on page 27.



Fig. 20 Right hand side of the multifunction steering wheel: menu operation and instrument cluster information exhibit buttons.

Depending on the version and model of your vehicle, the multifunction steering wheel may vary.

While a priority 1 warning message is displayed, it is not possible to call up any menu. All warning messages automatically disappear after a few

Radio controls and display

📖 Introduction



The radio concentrates important vehicle systems in a central control unit, such as the configurations menu or the radio function.

Basic command information

The text below contains relevant information for the configuration of the **Vehicle settings** menu. The basic radio system control information as well as the safety and warning displays to be followed are described → page 137.

System settings and vehicle information display - radio variant 1

Depends on the radio and vehicle version.

After pressing the radio system  button, the information can be displayed or settings can be adjusted touching the respective touch pad function. For example, by touching the selection function button  on the **Vehicle status** menu, it is possible to check on the actual status of systems or system failures to be shown.

- Vehicle settings → page 29.
- Active media.
- Trip data.
- Vehicle status.
- Convenience item.
- Radio station selection.

System settings and vehicle information display - radio variant 2

Depends on the radio and vehicle version.

It is possible to display information or adjust settings on the radio display by pressing the button  and by touching the respective function surfaces:

- Vehicle settings → page 29.
- Active media.
- Convenience item.
- Radio station selection.

Depending on the vehicle version, some information and settings can be performed on the main radio screen, dragging to the left and selecting the respective function:

- Trip data.
- Vehicle status.
- Operating mode → page 117.
- Active Info Display → page 16.
- Power monitor - Sport function → page 30



WARNING

Accidents and injuries can occur if the driver is distracted. Operation of the radio system may distract from the surrounding traffic happenings.

- Always drive carefully and responsibly.



 After starting the engine with the vehicle's 12 V battery completely flat, or with a replacement battery in the vehicle, the system's configuration (time, date, convenience and programming configurations) may have been deleted or become corrupted. Check and adjust the settings after the 12 V vehicle battery has been sufficiently recharged.

Menu Vehicle settings

 Please refer to  at the start of the chapter on page 29.

In the Infotainment system vehicle settings, you can switch individual functions and systems on and off as well as carry out settings.

Accessing the Vehicle settings menu

- Switch on the ignition.
- Case required turn the radio system on.
- Press .
- Touch the function button  to open the **Vehicle Settings** menu.
- Touch the respective function buttons on the **Vehicle settings** menu to access other menus or to configure the menu items. **OR**
- Touch the  function button to open the menu.
- Touch the respective function buttons on the **Car** menu to access other menus or to configure the menu items.

When the selection box on the function button is ticked off , the corresponding function is enabled.

The changes to the settings menus are automatically assumed immediately after having been made.

Touching the  function button returns you to the previous menu.

Power monitor - Sport function



 Please refer to  at the start of the chapter on page 29.



Fig. 21 On radio display: vehicle data monitor.

The power monitor is a display for sports driving. The digital instruments indicate in real time the relative values for the pressure in bar, the speed, the temperature and the position of the accelerator pedal, which are determined by means of the vehicle's sensors. This provides a dynamic driving overview to the driver.



Depending on the vehicle and radio version, the power monitor may not be available.

Open vehicle data monitor

- On the main radio screen, swipe left once and select .
- The vehicle data monitor opens on the display → Fig. 21.

The following instruments can be displayed:

- **Turbo (load pressure indicator):** the load pressure indicator shows the charge circuit pressure between the turbocharger and the engine (in “bar”). The farther right the needle, the higher the engine power.
- **Tachometer:** the tachometer indicates the number of engine revolutions per minute (RPM). In order to calculate the number of revolutions around an axis, the frequency unit RPM is multiplied by 1000 (revolutions x 1,000 per minute of the engine running).

- **Gear indicator:** shows the currently engaged gear or the selector lever position.
- **Digital speed indicator:** shows the vehicle's current driving speed (in km/h).
- **Throttle:** the Throttle Position Sensor (TPS) shows the throttle position. The horizontal bar moves to the right as the accelerator pedal is pressed.
- **Engine coolant temperature indicator:** this indicator is equivalent to the temperature gauge on the instrument cluster. If the engine is submitted to excessive stress or high exterior temperatures, the horizontal bar moves to the right. This is of no relevance as long as the control indicator light  does not light up or blink on the instrument cluster.
- **Fuel level indicator:** this indicator is equivalent to the fuel gauge on the instrument cluster. As the vehicle consumes fuel, the horizontal bar moves to the left. This is of no relevance as long as the control indicator light  does not light up on the instrument cluster.

WARNING

Accidents and injuries can occur if the driver is distracted. Operating the radio unit may distract drivers from the surrounding traffic.

- Always drive carefully and responsibly.

NOTICE

After cold engine starting, avoid high engine revs, overloading and excessive acceleration.

 Due to the principle of determining the power available in the vehicle, values displayed do not guarantee physical accuracy.

Safety

Overall guidelines

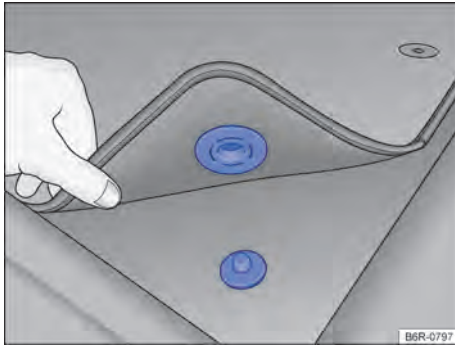



Fig. 22 Driver side mat attached to the floor pin.

Preparations for travel and driving safety

Observe the following information both before and during every journey to ensure your own safety, and the safety of all passengers and other road users → :

- ✓ Check that all lights and turn signals are working properly.
- ✓ Check the tyre pressure (→ page 236) and fuel level (→ page 14).
- ✓ Ensure that you have a good, clear view through all of the windows.
- ✓ The supply of air to the engine may not be suppressed and the engine should not be covered with covers or insulating materials →  in *Safety guidelines for work in the engine compartment* on page 214.
- ✓ Secure any objects and luggage in the stowage compartments, the luggage compartment or on the roof → page 178.
- ✓ Ensure that you are able to operate the pedals freely at all times.
- ✓ Secure any children travelling in the vehicle in a restraint system suitable for their weight and size → page 49.
- ✓ Adjust the front seats, headrests and mirrors properly in accordance with the size of the occupants → page 32.
- ✓ Wear proper shoes that provide good grip for your feet when using the pedals.

- ✓ The floor mat in the footwell on the driver side must be securely fastened to ensure the pedal area is unobstructed. The driver side mat might be attached to the floor pin → Fig. 22.
- ✓ Assume a correct sitting position before and while driving. This also applies to all passengers → page 32.
- ✓ Fasten your seat belt correctly before setting off and keep it properly fastened throughout the journey. This also applies to all passengers → page 34.
- ✓ Each vehicle occupant must sit in a seat of their own and must have their own seat belt.
- ✓ Never drive if your driving ability is impaired, e.g. by medication, alcohol, drugs, among other substances capable of influencing your perception and reaction.
- ✓ Do not allow yourself to be distracted from the traffic (e.g. by passengers, telephone calls, browsing through display menus.)
- ✓ Always adjust speed and driving pattern according to visibility, climate, road, and traffic conditions, under respective speed limits.
- ✓ Observe traffic regulations and speed limits.
- ✓ When travelling long distances, stop and take a break regularly – at least every two hours.
- ✓ Carry animals in the vehicle using restraint systems based on their weight and size.

Driving abroad

Some countries adopt special safety regulations and relevant prescriptions for exhaust gases which may differ from the structural condition of the vehicle. Volkswagen recommends that you learn about any legal requirement and the following issues concerning your destination before travelling abroad:

- ✓ Does the vehicle need any technical modifications for driving abroad, e.g. masking or switching the headlights over?
- ✓ Are the necessary tools, diagnostic equipment and spare parts available for service and repair work?
- ✓ Is there a Volkswagen Dealership in the destination country?
- ✓ Is there unleaded petrol with the correct octane number and free of metallic additives (such as manganese) in the destination country? 

Driving abroad (Continued)

- ✓ Are the correct engine oil (→ page 218) and other service fluids that comply with Volkswagen specifications available in the destination country?
- ✓ Are special tyres required for travelling in the destination country?

Checks when fuelling

Never carry out any work on the engine or in the engine compartment if you are not familiar with the necessary procedures and the general safety requirements, as well as without available resources, fluids and tools → page 213! The work should be carried out by a Volkswagen Dealership or qualified workshop. Please ensure that the following points are checked regularly, preferably every time you fill the tank:

- ✓ Windscreen washer fluid level → page 217
- ✓ Engine oil level → page 218
- ✓ Engine coolant level → page 222
- ✓ Brake fluid level → page 224
- ✓ Tyre pressure → page 236
- ✓ Vehicle lighting necessary for traffic safety:
 - Turn signals
 - Side light, dipped beam and main beam headlights
 - Tail light lamps
 - Brake light
 - Number plate light

Information about changing bulbs → page 197.

DANGER

Follow the important safety instructions related to the front passenger's front airbag → page 51, *Installation and child seat usage in the vehicle*.

WARNING

Driving under the influence of alcohol, drugs, medication and/or narcotics can cause serious accidents and fatal injuries.



- Alcohol, drugs, medication and/or narcotics can severely impair perception, reaction times and driving safety. This could cause you to lose control of the vehicle.

WARNING

Always observe current traffic regulations and speed limits, and think ahead when driving. Correct interpretation of a driving situation can make the difference between reaching your destination safely and having an accident with severe injuries.

NOTICE

Volkswagen may not be held liable for damages caused to the vehicle due to low-quality fuel, insufficient/incorrect maintenance, and use of non-genuine parts.

 Regular servicing of your vehicle not only maintains its value, but also ensures that your vehicle remains roadworthy and in perfect working order. Servicing work should therefore always be carried out in accordance with the Volkswagen maintenance guidelines. Under severe operating conditions it may be necessary to carry out some maintenance jobs prior the next scheduled service. Additional information on adverse conditions is available on → page 249, which prior reading is essential. Contact a Volkswagen Dealership for more information. 

Adjusting the seat position

Introduction

Number of seats

The vehicle has a total of 5 seats: 2 front seats and 3 rear seats. Each seat is equipped with safety belts.

WARNING

Assuming an incorrect sitting position in the vehicle can increase the risk of severe or fatal injuries during a sudden driving or braking manoeuvre, in the event of a collision or accident, or if the airbags are triggered.

- All vehicle occupants must assume a correct sitting position before setting off and maintain this position throughout the trip. This also applies to the use of seat belts. 

- The number of vehicle occupants must never exceed the number of seats with seat belts in the vehicle.
- Always secure children in the vehicle with an authorised restraint system suitable for their height and weight → page 49, *Transporting children in the vehicle*, → page 42, *Airbag system*.
- Always keep your feet in the footwell while the vehicle is in motion. Never place your feet on the seat or on the dash panel and never hold your feet out the window. The airbag and seat belt can otherwise not provide optimal protection and can actually increase the risk of injury during an accident.

- Never put your feet on the dash panel.
- Never place your feet on the seat cushion or seat backrest.
- Never travel in a footwell.
- Never travel on a seat without wearing the seat belt.
- Never travel in the internal luggage compartment.

⚠ WARNING

Any incorrect sitting position in the vehicle increases the risk of severe or fatal injuries in the event of an accident or sudden driving or braking manoeuvre.

- All vehicle occupants must maintain a correct sitting position and wear their seat belt properly while the vehicle is in motion.
- Sitting in an incorrect position, not fastening the seat belt, or leaving too short a distance to the airbag exposes the occupants to the risk of sustaining critical or fatal injuries, especially if the airbags are triggered and strike an occupant who has assumed an incorrect sitting position.

Dangers of an incorrect sitting position

📖 Please refer to **⚠** at the start of the chapter on page 32.

If the seat belts are not worn or are worn incorrectly, the risk of severe or fatal injuries increases. Seat belts can only provide optimal protection if the seat belt routing is correct. An incorrect sitting position considerably impairs the level of protection provided by the seat belts. This could lead to severe or even fatal injuries. The risk of severe or fatal injuries is especially augmented when a triggered airbag hits an occupant who has assumed an incorrect sitting position. The driver is responsible for all vehicle passengers, especially if they are children.

The following list contains examples of sitting positions that could be dangerous for all occupants.

Whenever the vehicle is in motion:

- Never stand in the vehicle.
- Never stand on the seats.
- Never kneel over the seats.
- Never tilt the backrest too far to the rear.
- Never lean against the dash panel.
- Never lie on the rear seat.
- Never sit on the front edge of a seat.
- Never sit sideways.
- Never lean out of a window.
- Never put your feet out of a window.

Correct sitting position

📖 Please refer to **⚠** at the start of the chapter on page 32.

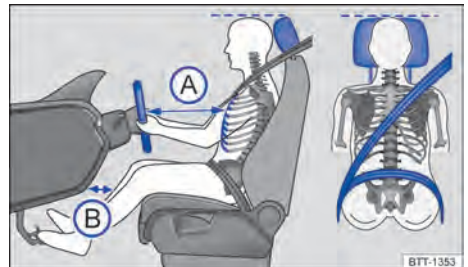

Fig. 23 Correct distance between the driver and the steering wheel, correct seatbelt position and correct headrest adjustment.

The following points describe the correct sitting positions for the driver and passengers.

Persons who due to their physical build are unable to sit correctly in the vehicle should contact a Volkswagen Dealership to learn about possible special installations. The seat belts and airbags

can only provide a maximum level of protection if a correct sitting position is assumed. Volkswagen recommends using a Volkswagen Dealership for this purpose.

Volkswagen recommends the following sitting positions on the seats for the occupants own safety and to reduce the level of injury in the event of a sudden braking manoeuvre or an accident:

Points for the driver:

- Move the backrest into an upright position so that your back rests fully against it.
- Adjust the seat so that the distance between the steering wheel and the driver's chest is at least of 25 cm → Fig. 23 (A) and so the driver can firmly hold the steering wheel by its outer rim with both hands and with slightly flexed arms.
- The steering wheel must always point towards the breastbone and not towards the face.
- Adjust the driver's seat lengthwise so that the pedals may be reached with slightly flexed legs and so that the distance between the knees and the dashboard is at least 10 cm → Fig. 23 (B).
- Adjust the height so that you can reach the highest point of the steering wheel.
- Always leave both feet in the footwell to maintain control of the vehicle at all times.
- Fasten seat belts properly → page 34.

Points for the front passenger:

- Move the backrest into an upright position so that your back rests fully against it.
- Push the front passenger seat as far back as possible so that the airbag can provide maximum protection if it is triggered.
- Always keep your feet in the footwell while the vehicle is in motion.
- Fasten seat belts properly → page 34.

Points for rear vehicle passengers:

- Adjust the head rest so its top edge is at the same height as the top of the head → Fig. 23 – but not below eye level. Position the back of your head as close to the head restraint as possible.
- In case of short stature individuals, push the head restraint all the way down, even if the head is then located underneath the top edge of the head rest.
- For taller people, push the head rest up as far as possible.
- Always keep your feet in the footwell while the vehicle is in motion.
- Adjust and fasten seat belts properly → page 34.

Seat belts

Introduction

Check the condition of all seat belts regularly. In case of damages to belts, connections, automatic belt retractor, or seat belt latches, the respective seat belt must be immediately replaced by a Volkswagen Dealership → ⚠. One must use correct spare parts that are compatible with the vehicle, equipment level and model year. Volkswagen recommends using a Volkswagen Dealership for this purpose.

⚠ WARNING

Incorrectly fastened or unfastened seat belts increase the risk of severe or fatal injuries. Seat belts will only offer the optimum level of protection when they are fastened and used properly.

- Seat belts are the most effective means of reducing the risk of severe and fatal injuries in case of accidents. For the protection of the driver and of all vehicle occupants, seat belts must always be fastened properly when the vehicle is in motion.
- Before every trip, each vehicle occupant must assume a correct sitting position, correctly fasten the seat belt belonging to their

seat and keep it fastened properly throughout the trip. This applies to all passengers in any traffic condition.

- While the vehicle is in motion, secure all children travelling in the vehicle in a restraint system suitable for their age, as well as properly secured seat belts → page 49, *Transporting children in the vehicle.*
- Only start driving when all passengers have correctly fastened their seat belts.
- Only ever insert the latch plate into the buckle of the associated seat, and always ensure that it engages properly. Using a buckle that does not belong to the seat that you are occupying reduces the level of protection and can lead to severe injuries.
- Never let any foreign bodies or liquids enter the seat belt buckle slot. This could prevent belt buckles from working properly.
- Never unfasten the seat belt while the vehicle is in motion.
- Never allow more than one person to share the same seat belt.
- Never allow children or babies to be transported on someone's lap, or while being held.
- Never drive wearing loose, bulky clothing (such as an overcoat over a jacket). This could prevent the seat belts from fitting and functioning properly.

WARNING

Damaged seat belts are extremely dangerous and can cause severe or fatal injuries.

- Never damage the belt by trapping it in the door or in the seat mechanism.
- If the belt bands fabric or any other part of the seat belt becomes damaged, the seat belt may tear during an accident or sudden braking manoeuvre.
- Damaged seat belts must be replaced immediately with new seat belts at a Volkswagen Dealership. Seat belts used during an accident and subjected to stress or belt tensioner activation must be replaced by a Volkswagen Dealership. Replacement may be necessary even if there is no apparent damage. The belt anchorage should also be checked.

- Never attempt to repair, modify or remove the seat belts yourself. All repairs to seat belts, belt retractors and buckles must be carried out by a Volkswagen Dealership.

Warning lamp



 Please refer to  at the start of the chapter on page 34.



Fig. 24 Instrument cluster display warning lamp.



Fig. 25 Seat belt status indicator for rear seats in the instrument cluster display.

An acoustic warning sounds for a few seconds if the seat belts are not fastened prior to reaching a speed of approximately 25 km/h or whenever the seat belts are unfastened while driving. In addition, the warning lamp flashes  → Fig. 24.

The warning light  only turns off, with the ignition switched on, after the driver and front passenger have fastened their respective seat belts.

Rear seat belt status indicator

After switching the ignition on, the seat belt status indicator → Fig. 25 shows in the instrument cluster display whether rear seat passengers have fastened their seat belts.



The symbol indicates that the passenger in this seat has fastened the seat belt.



The symbol indicates that the passenger in this seat has not fastened the seat belt.

The seat belt status indication is shown for approximately 60 seconds whenever a seat belt is fastened or removed in the rear seats. The indication can be hidden by pressing **[0.0 / SET]** on the instrument cluster display.

If a rear seat belt is removed while driving, the seat belt status indicator flashes for up to 60 seconds. A sound warning is also activated when driving at speeds higher than 25 km/h.

⚠ WARNING

Incorrectly fastened or unfastened seat belts increase the risk of severe or fatal injuries. Seat belts will only offer the optimum level of protection when they are used properly.

Frontal collisions and the laws of physics

📖 Please refer to **⚠** at the start of the chapter on page 34.



Fig. 26 Unbelted occupants in a vehicle heading for a brick wall.

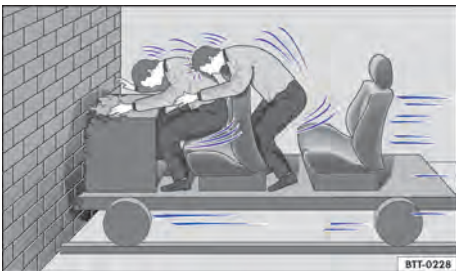

Fig. 27 Unbelted occupants in a vehicle striking a brick wall

The physical principles involved in a frontal collision are relatively simple. As soon as the vehicle is in motion → Fig. 26, both the moving vehicle and its passengers gain movement energy. Such energy is known as “kinetic energy”.

The higher the vehicle speed and the heavier the weight of the vehicle, the greater the amount of energy that will have to be released in the event of an accident.

However, the most significant factor is the vehicle speed. For example, when the speed doubles from 25 km/h to approximately 50 km/h (15 mph to approximately 30 mph), the kinetic energy increases fourfold!

◀ The amount of “kinetic energy” depends on the vehicle speed and weight of the vehicle and passengers. The higher the speed and the heavier the weight, the greater the amount of energy that will be released in the event of an accident.

Passengers not wearing seat belts are, therefore, not “connected” to the vehicle. In the event of a frontal collision they will continue to move forward at the same speed at which the vehicle was travelling before impact, until something stops them. Because the passengers in our example are not restrained by seat belts, the entire amount of kinetic energy will only be released at the point of impact against the wall → Fig. 27.

At a speed of approximately 50 km/h (30 mph), the forces acting on the body during an accident can easily exceed one tonne (1,000 kg). These forces are even greater at higher speeds.

This example applies not only to frontal collisions, but to all kinds of accidents and collisions. ◀

What happens to passengers who have not fastened their seat belts

📖 Please refer to ⚠ at the start of the chapter on page 34.



Fig. 28 An unbelted driver is thrown forward.



Fig. 29 The unbelted rear passenger is thrown forward violently, hitting the belted driver.

Many people believe that they can brace their weight with their hands in a minor collision. This is not true.

Even at low speeds, the forces acting on the body in a collision are so great that occupants cannot brace themselves with their arms and hands. In a frontal collision, unbelted passengers are thrown forward and will make unchecked contact with parts of the vehicle interior, e.g. the steering wheel, dash panel, or windscreen → Fig. 28.

The airbag system is not a substitute for the seat belts. When triggered, airbags only provide additional protection. Airbags are not triggered in all kinds of accidents. Even if the vehicle is equipped

with an airbag system, all vehicle occupants, including the driver, must fasten their seat belt and wear it correctly while the vehicle is in motion. This reduces the risk of severe or fatal injuries in the event of an accident - regardless of whether an airbag is available.

An airbag can only be triggered once. To achieve best possible protection, seat belts must always be worn properly. This also ensures that protection is provided in accidents in which the airbag is not triggered. Any vehicle occupant not wearing a seat belt can be thrown out of the vehicle and sustain even more severe or even fatal injuries as a result.

It is also essential for rear passengers to wear seat belts properly, as they could otherwise be thrown forward violently in an accident. Rear passengers who are not wearing seat belts endanger not only themselves and the driver, but also other people in the vehicle → Fig. 29.

Seat belts protect

📖 Please refer to ⚠ at the start of the chapter on page 34.

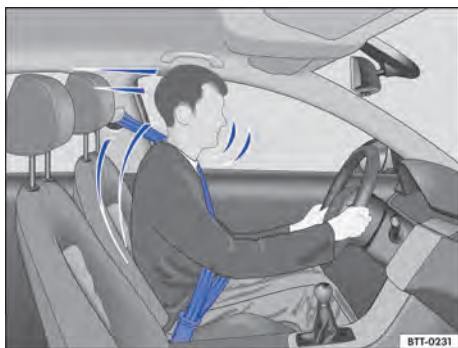

Fig. 30 Driver restrained by a properly positioned seat belt during a sudden braking manoeuvre.

Correctly fastened seat belts can make a major difference. When fastened properly, seat belts hold the vehicle occupants in the correct sitting positions and considerably reduce the kinetic energy in the event of an accident. Seat belts also help to prevent uncontrolled movements that could lead to severe injuries. Additionally, wearing seat belts properly reduces the risk of being thrown from the vehicle → Fig. 30.

Passengers wearing seat belts correctly benefit greatly from the ability of the belts to reduce the kinetic energy generated. The front crumple zones and other passive safety features (such as the airbag system) are also designed to mitigate kinetic energy. The amount of energy generated will thus decrease, thereby reducing the risk of injury.

The illustrated examples describe frontal collisions. Properly worn seat belts also substantially reduce the risk of injury in all other types of accidents. This is why seat belts must be fastened before every trip - even if you only planning on going "around the block". Ensure that all passengers also wear their seat belts properly.

Accident statistics have shown properly worn seat belts to be an effective means of substantially reducing the risk of injury and improving the chances of survival in severe accidents. Furthermore, properly worn seat belts ensure proper airbag operation in case of accidents. This is why wearing a seat belt is a legal requirement in most countries.

Although the vehicle is equipped with airbags, seat belts must be used at all times. For example, the front airbags will only be triggered in certain types of frontal collision. Front airbags will not be triggered during minor frontal collisions, minor side collisions, rear collisions, rolls or accidents in which the airbag trigger threshold in the control unit is not exceeded.

Therefore, always wear your seat belt and ensure that your passengers have fastened their seat belts properly before driving.

- ✓ Never remove, modify or repair the seat belt or any part of the belt fixture system.
- ✓ Always fasten the seat belt correctly before driving and wear it properly while the vehicle is in motion.

Twisted seat belt

If it is difficult to remove the seat belt from the belt guide, the seat belt may have become twisted if it was returned too quickly into the side trim: In this case:

- Take hold of the latch plate then slowly and carefully pull out the seat belt.
- Untwist the seat belt and guide it back slowly by hand.



Fasten the seat belt even if you are unable to undo the twist. However, the twist should not be in an area of the seat belt that comes into direct contact with the body! The twist should be corrected immediately by a Volkswagen Dealership.

WARNING

Using seat belts incorrectly increases the risk of severe or fatal injuries.

- Regularly check to see if the seat belt and its related parts are in perfect working conditions.
- Keep the seat belts clean.
- Do not allow the belt bands to become jammed, damaged or to rub on any sharp edges.
- Always keep the latch plate and slot in the buckle free from foreign bodies and liquids.

Using seat belts

 Please refer to  at the start of the chapter on page 34.

Checklist

Using seat belts → :

- ✓ Check the condition of all seat belts regularly.
- ✓ Keep the seat belts clean.
- ✓ Never let any foreign bodies and liquids get on to the seat belt, the latch plate or into the slot for the seat belt buckle.
- ✓ Do not trap or damage the seat belt and latch plate (e.g. when closing the door).

Fastening and unfastening seat belts

📖 Please refer to ⚠ at the start of the chapter on page 34.

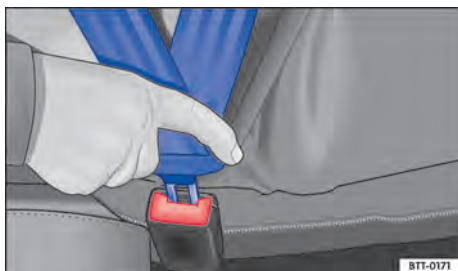

Fig. 31 Inserting the seat belt latch plate into the buckle.



Fig. 32 Removing the seat belt latch plate into the buckle.

If worn properly, seat belts hold the vehicle occupants in the correct sitting position during an accident or braking manoeuvre, giving occupants maximum protection → ⚠.

Fastening the seat belts

Fasten seat belts before driving.

- Always properly adjust the front seats and head rests (if equipped) → page 32.
- Lock the rear seat backrest in its proper position → ⚠.
- Gently pull the seat belt through the latch plate, across the chest and the pelvic area. **Do not** twist the seat belt → ⚠.
- Insert the latch plate securely into the buckle of the respective seat → Fig. 31.
- Pull test the seat belt to ensure that the latch plate is securely locked in the buckle.

Unfastening the seat belts

Unfasten seat belts only when the vehicle is stationary → ⚠.

- Press the red button in the buckle → Fig. 32. The latch plate is released and springs out.
- Guide the belt back so that it rolls up easily, without twisting the seat belt and without damaging the trim.

⚠ WARNING

Incorrect seat belt routing can cause severe or fatal injuries in the event of an accident.

- The seat belts only offer best protection when the backrests are in the proper position and the seat belts have been fastened properly according to the occupant's height.
- Unfastening seat belts while the vehicle is in motion can lead to severe or fatal injuries in the event of an accident or sudden braking manoeuvre.

Seat belt routing

📖 Please refer to ⚠ at the start of the chapter on page 34.

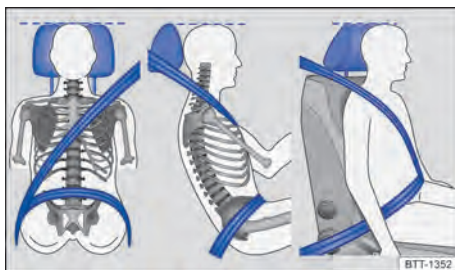

Fig. 33 Correct seat belt routing and head rest adjustment.



Fig. 34 Correct seat belt routing during pregnancy.

Seat belts only provide an optimum level of protection during an accident and reduce the risk of severe or fatal injuries when they are routed correctly. Correct seat belt bands routing also holds the vehicle occupants in position so that an inflating airbag can offer the maximum level of protection. Therefore always fasten your seat belt and ensure that the seat belt routing is correct.

An incorrect sitting position can cause severe or fatal injuries → page 32, *Adjusting the seat position*.

Correct seat belt routing

- The shoulder part of the seat belt must always lie on the centre of the shoulder, never across the neck, over or under the arm, or behind the back.
- The lower seat belt strap must always lie across the pelvis, never across the stomach.
- The seat belt must always lie flat and firm against the body. Slightly stretch the seat belt if necessary → Fig. 33.

For **pregnant women**, the seat belt must be positioned over the chest and as low as possible over the pelvis, so that no pressure is exerted on the lower body – this applies to all pregnancy stages → Fig. 34.

Correct seat belt routing according to height

The seat belt routing can be adjusted as follows:

- Belt height adjuster for the front seats → page 41.
- Front seat with height adjustment → page 74.

⚠ WARNING

Incorrect seat belt routing can cause severe injuries in the event of an accident or a sudden braking / driving manoeuvre.

- The seat belts only offer best protection when the backrests are in the proper position and the seat belts have been fastened properly.
- The shoulder part of the seat belt must lie on the centre of the shoulder and never under the arm or across the neck.
- The seat belt must lie flat and firmly over the chest.
- The lower seat belt strap must always lie across the pelvis, never across the stomach. The seat belt must lie flat and firmly over the pelvis. Slightly loosen the seat belt if necessary.
- For pregnant women, the lap part of the seat belt must be as low as possible over the pelvis around the “bulge” of the belly.
- Do not twist the belt bands while securing the seat belt.
- Never hold the seat belt away from the body by hand.
- The belt bands should not lie over hard or fragile objects, such as glasses, pens or keys.
- Never use seat belt clips, retaining rings or similar items to alter the seat belt routing.

i If a person's physical build prevents them from routing the seat belt properly, contact a Volkswagen Dealership to find out about any special modifications so that the seat belts and airbags can provide the optimum level of protection. ◀

Belt height adjuster

📖 Please refer to ⚠ at the start of the chapter on page 34.



Fig. 35 Next to the front seats: seat belt height adjuster.

Depending on the vehicle's version, seat belt height adjustment may not be available.

The seat belt height adjusters for the front seats can be used to adjust the seat belt position on the shoulder area according to the body size, so it can be fastened properly:

- Press and hold the shoulder belt guide as indicated by the arrows → Fig. 35.
- Push the shoulder belt guide up or down so that the seat belt lies over the middle of the shoulder → page 39, *Seat belt routing*.
- Let go of the shoulder belt guide.
- Pull sharply on the seat belt to check whether the shoulder belt guide is engaged securely.

⚠ WARNING

Never adjust the seat belt height when the vehicle is in motion.

Automatic belt retractor, belt tensioner and belt roll-back function

📖 Please refer to ⚠ at the start of the chapter on page 34.

Seat belts are part of the vehicle's safety system → page 45 and are made up of the following important functions:

Automatic belt retractor

The safety belts are fitted with an automatic retriever roller, this device keeps the safety belt adjusted to the passenger's body. Full freedom of movement in the passenger's upper body area is made possible when the seat belt is pulled slowly or when the vehicle is travelling at normal speeds. However, the automatic belt retractor locks the seat belt if the belt is pulled out quickly, during sudden braking, when driving uphill or downhill or around bends, and during acceleration.

Seat belt tensioners

Front seat belts are equipped with belt tensioners and roll-back function. Rear seat belts are not equipped with these features.

Belt tensioners are activated by sensors during severe frontal and rear collisions, tightening the seat belts against the direction in which they are pulled. Safety belt clearances are eliminated when the belt tensioner is activated, reducing the forward movement of passengers towards the impact direction. Belt tensioners works together with the airbag system. Belt tensioners are not activated in minor front collisions, rolls or accidents in which the threshold in the control unit is not exceeded.

- ◀ A fine dust may be generated upon activation. This is perfectly normal and does not represent fire risk.

Seat belt roll-back function

The front seat belts are equipped with roll-back function.

The seat belt roll-back function minimizes seat belt force acting over the body in case of accidents.

 All safety requirements must be observed when the vehicle or components of the system are scrapped. Volkswagen Dealerships are familiar with such requirements.

Airbag system

Introduction

The vehicle is equipped with one front airbag for the driver and one for the passenger. Front airbags can provide the driver and front passenger with additional chest and head protection if the seat, seat belts, head rests and, in the case of the driver, steering wheel are adjusted and used correctly. Airbags are meant to provide additional protection. Airbags are not a substitute for seat belts. Seat belts must always be worn, even when the vehicle is equipped with front airbags.

WARNING

Never rely solely on the airbag system for your protection.

- Even if an airbag is triggered, it only offers additional protection.
- The airbag system only enhances protection if the seat belt is properly used, in order to mitigate injuries → page 34, *Seat belts*.
- Before every trip, each vehicle occupant must assume a correct sitting position, correctly fasten the seat belt belonging to their seat and keep it fastened properly throughout the trip.

WARNING

The risk of injury increases if there are any items located between the occupant and the deployment area of the airbag when it is triggered. This will impinge on the deployment zone of the airbag or the items will be flung against the body.

- Never hold any objects in your hand or on your lap while the vehicle is in motion.
- Never transport any objects on the front passenger seat. Objects could enter the deployment zone of the airbag during sudden braking or driving manoeuvres and then be flung dangerously through the vehicle interior if the airbag is activated.
- People, animals or objects must never be in-between the vehicle's front seat occupants, the rear side seat occupants and the airbag expansion areas. Ensure this is also followed by children and passengers.

Service and disposal of belt tensioners

 Please refer to  at the start of the chapter on page 34.

Seat belts may become damaged during any work on the belt tensioners or while removing or refitting any vehicle parts in conjunction with any other repair work. Such damages will not always be noticeable. The consequence may be that the belt tensioners could function incorrectly, or not function at all, in the event of an accident.

Regulations must be observed to ensure that the effectiveness of the belt tensioner is not reduced and that removed parts do not cause any injuries or environmental pollution. Volkswagen Dealerships are familiar with such requirements.

WARNING

The risk of severe or fatal injuries may be increased if the seat belts, automatic belt retractors and belt tensioners are not used correctly, or if they are repaired by a non-professional. In this case, the belt tensioners may not be triggered when they should, or they may be triggered unexpectedly.

- Only Volkswagen → page 260, *Accessories, modifications, repairs and part replacement* may carry out repairs, adjustments or removal and refitting of parts in the belt tensioner system or seat belts.
- Belt tensioners and automatic belt retractors cannot be repaired. They must be replaced.
- Belt tensioners can only be activated once. Once the belt tensioners are activated, they must be replaced.

 Airbag modules and belt tensioners may contain toxic substances. This product cannot be disposed / discarded along with common trash. For your own safety and comfort, Volkswagen recommends replacing belt tensioners and airbag modules only at Volkswagen Dealerships.

⚠ WARNING

The airbag system only supports a single airbag triggering event. If the airbags are triggered, the airbag system must be replaced.

- Airbags that have been triggered, and any affected system parts, must immediately be replaced with new parts that are approved by Volkswagen for the vehicle.
- Airbag system repairs and part replacements must only be carried out by Volkswagen Dealerships. Volkswagen Dealerships have the necessary tools, diagnostic equipment, repair information and qualified personnel for this purpose.
- Never use recycled airbag components or components that have been taken from end-of-life vehicles in your vehicle.
- Never alter any components of the airbag system.

⚠ WARNING

A fine dust (non-toxic) may be generated upon activation. This is perfectly normal and does not represent fire risk.

- The fine dust can cause irritation to the skin and eye membranes and cause breathing difficulties, particularly for people suffering from asthma or people who have or had other respiratory problems. To help reduce breathing difficulties, get out of the vehicle or open the windows or doors for more fresh air.
- If you come into contact with the dust, wash your hands and face with a mild soap and water before eating.
- Do not let the dust get into your eyes or into open wounds.
- If dust has entered your eyes, rinse them with water.

⚠ WARNING

Cleaning products cause the airbag module surfaces to become porous and brittle. In case of activation, such parts could break and cause severe injuries.

- Never apply any chemical or cleaning products to the airbag module surfaces. Use only damp cloths to clean these areas.



Front passenger front airbag system type

📖 Please refer to ⚠ at the start of the chapter on page 42.

Front passenger airbag system with front airbag deactivation

The front passenger airbag is manually deactivated through a switch activated by the vehicle key → page 47.

Signs of the airbag system with front passenger airbag deactivation:

- Front passenger front airbag in the dash panel.
- Indicator lamp  on the Instrument cluster display.
- Indicator lamp PASSENGER AIR BAG OFF  in the upper part of the centre console.
- Indicator lamp PASSENGER AIR BAG ON  in the upper part of the centre console.
- Key-activated switch next to the dash panel on the front passenger side (visible only with open door).

Indicator lamp

📖 Please refer to ⚠ at the start of the chapter on page 42.





Fig. 36 In the upper part of the centre console: front passenger front airbag indicator lamp off [A] or on [B].

 The yellow indicator lamp on the instrument cluster display lights up briefly after switching on the ignition to test for proper operation, and goes off after a few seconds.

OFF  Front passenger front airbag disabled. The yellow indicator lamp on the centre console is permanently on → Fig. 36 [A].

ON  Front passenger front airbag enabled. The yellow indicator lamp on the centre console turns off automatically around 60 seconds after turning the ignition on or after enabling the front passenger front airbag with the key-activated switch → Fig. 36 [B].



If, with **disabled** front passenger front airbag, the PASSENGER AIR BAG **OFF**  indicator lamp in the upper part of the centre console **is not permanently lit** or if it lights up together with the  indicator lamp on the instrument cluster, the airbag system may be malfunctioning → .

DANGER

When the airbag system indicator lamp is lit, there are damages in the airbag system and it may not trigger correctly, may not trigger at all or may trigger unexpectedly. This can cause severe or fatal injuries.

- The airbag system must be checked by a Volkswagen Dealership as soon as possible.
- Never fit a child seat on the front passenger seat while the airbag system is activated! The passenger front airbag may be triggered in an accident, despite damages.

Troubleshooting

 Please refer to  at the start of the chapter on page 42.

Airbags system or belt tensioner damaged

The yellow indicator lamp is permanently on. A message will also be shown on the instrument cluster display.

A malfunction was identified in at least one airbag or belt tensioner.

- Contact a Volkswagen Dealership.
- Belt tensioners and the airbag system must be checked.

OFF Front passenger front airbag disabled

The yellow indicator lamp is permanently on for the deactivated front passenger front airbag.

The front passenger front airbag is deactivated.

- Check whether the front passenger front airbag needs to stay deactivated, for instance, while using a child seat on the front passenger seat.



ON Front passenger front airbag enabled

The yellow indicator lamp for the front passenger front airbag turns on for approximately 60 seconds after turning the ignition on or after activating the front passenger front airbag with the key-activated switch.

The front passenger front airbag is on.

- Check whether the front passenger front airbag should remain on.

Description and function of the airbags

 Please refer to  at the start of the chapter on page 42.

The airbag protects the vehicle's occupants in an accident, cushioning the occupant's movements in case of frontal collisions.

When an airbag is triggered, it is inflated by a gas generator. This causes the airbag covers to break, and the airbags inflate forcefully to cover their deployment zones within milliseconds. After holding vehicle occupants in place, who must always wear their respective seat belts, inflated airbags release a gas through openings located away from the vehicle occupants. This can reduce the risk of severe and fatal injuries. A triggered airbag will not always prevent other injuries such as swelling, bruising and grazing. Heat by friction can also be generated during an airbag triggering event.

Airbags provide no protection for the arms or lower body parts.

The most important factors regarding airbag triggering are the type of accident, the vehicle impact area, the angle, the intensity of the impact, the vehicle structure, and the obstacle to which the vehicle collided. Therefore, airbags are not triggered in all collisions.

The airbag system's triggering depends on the intensity of the impact registered by an electronic control unit. If the accident's characteristics do not fall under the parameters configured in the control unit, the airbags are not triggered. Vehicle damages and cost repairs are used as indicators that the airbag system should have been triggered. Important factors in the triggering of the airbag include the nature (hard or soft) of the object that the vehicle hits, the angle and intensity of impact, and the vehicle impact area.



Airbags are merely used as additional safety features for the seat belts in some accidents in which the impact intensity is sufficient to trigger the airbags. Airbags can only be triggered once and only in certain situations. The seat belts are always there to provide protection in situations in which the airbags are not triggered or have already been triggered. For example, if the vehicle collides with a further vehicle following the initial collision, or is hit by another vehicle.

The airbag system is part of the vehicle's overall passive safety concept. The airbag system can only work effectively when the occupants are wearing their seat belts correctly and have assumed a proper sitting position  → page 32.

Components of the vehicle safety concept

The following vehicle safety equipment makes up the vehicle's safety concept to reduce the risk of severe and fatal injuries. Depending on the vehicle version, some of the equipment may not be fitted in your vehicle or may not be available at all in some countries.

- Front airbags for driver and front passenger.
- Driver and front passenger's airbags.
- Height-adjustable head restraints optimised for rear impact.
- Seats.
- Optimised seat belts for all seats.
- Adjustable steering column.
- Brakes / parking brakes.
- Belt tension limiter for the driver and front passenger.
- Seat belt warning lamp .

- Airbag indicator lamp .
- PASSENGER AIR BAG OFF  indicator lamp on the upper part of the centre console.
- PASSENGER AIR BAG ON  indicator lamp on the upper part of the centre console.
- Belt tensioners for the driver and front passenger.
- Belt height adjuster for the front seats.
- If necessary, child seat anchoring points on the rear side seats.
- If necessary, anchoring point for the upper child seat fastening belt.
- Sensors and control units.

Situations in which the front and side airbags are not triggered:

- If the ignition is switched off during a collision.
- If the impact intensity measured in control units is too small during frontal collisions.
- During minor side collisions.
- During rear collisions.
- If the vehicle rolls over.
- If the impact intensity measured by the control unit is insufficient to trigger the airbags.

In case of airbag triggering - Crash detection function

Whenever airbags are deployed during an accident, the crash detection function is activated and the following actions may occur:

- Vehicle doors unlocking (valid for vehicles equipped with central locking system) → page 63.
- Fuel supply cut off → page 189.
- Activation of inner vehicle lights → page 85.
- Activation of warning lamps → page 58.

Warning lamps may be switched off via the dash panel switch. 

Front airbags

📖 Please refer to ⚠️ at the start of the chapter on page 42.

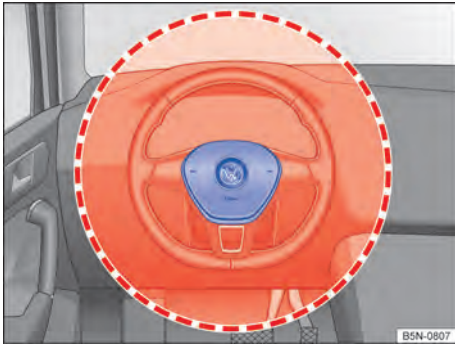

Fig. 37 Location and deployment zone of the driver front airbag.

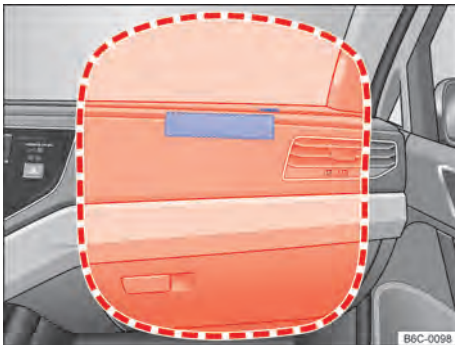

Fig. 38 Installation location and expansion zone of the passenger front airbag.

In conjunction with the seat belts, the front airbag system gives the front occupants additional protection for the head and chest in the event of a severe frontal collision. Farthest distance from the front airbag is recommended; at least 25 cm → page 32. This allows the front airbags to inflate fully when triggered, thus providing maximum protection.

The driver's front airbag is placed in the steering wheel → Fig. 37 and the front airbag for the front passenger is placed in the dash panel → Fig. 38. Airbag locations are identified by the text "AIR-BAG".

The areas highlighted in red → Fig. 37 and → Fig. 38 are covered by the front airbags when triggered (deployment zone). For this reason, you must never leave or attach any items in these areas → ⚠️.

The airbag covers fold out from the steering wheel → Fig. 37 or from the dashboard → Fig. 38 when the driver and passenger front airbags are triggered. The airbag covers remain connected to the steering wheel or the dashboard.

⚠️ DANGER

Once triggered, the airbag inflates at high speed.

- Always leave the deployment zones of the front airbags clear.
- Never attach any items, such as drink or telephone holders, GPS, etc., to the covers of the airbags or anywhere in the airbag deployment zone.
- Front seat occupants must never carry any people, pets or objects in the deployment zone between themselves and the airbags.
- Do not attach objects, such as GPS devices, to the windscreen above the front passenger's front airbag.
- Do not attach, line, modify, or place any materials over the centre steering wheel surface (horn activation) and the front passenger airbag module surface, on the dash panel.

⚠️ WARNING

The front airbags are triggered in front of the steering wheel → Fig. 37 and dash panel → Fig. 38.

- When driving, always hold the steering wheel with both hands on the outside of the ring: 9 o'clock and 3 o'clock positions.
- Adjust the driver seat in such a way that there is at least 25 cm between your breastbone and the hub of the steering wheel. If your physical build makes it impossible to fulfil this requirement, you must contact a Volkswagen Dealership in order to implement any necessary modifications.
- Adjust the passenger seat so that the distance between the passenger and the dashboard is as wide as possible. ▶

 Airbag system parts must never be reused in case of vehicle or component scrapping. All applicable environment disposal standards must be followed, in addition to other safety standards in effect. Volkswagen Dealerships are familiar with such requirements.

Switching the passenger front airbag on and off manually with the key activated switch



 Please refer to  at the start of the chapter on page 42.







Fig. 39 On the dash panel on the front passenger side: key activated switch to enable or disable the front passenger front airbag.

Depending on the vehicle version, the front passenger airbag on/off switch may not be available.



When securing a rear-facing child seat in the front passenger seat, the front passenger front airbag must be switched off!

Enabling the front passenger front airbag



- Switch off the ignition.
- Open the front passenger door.
- Unfold the vehicle key bit → page 60.
- Using the key bit, turn the key-activated switch → Fig. 39 →  to  **ON**.
- Remove the vehicle key from the key activated switch and fold the key bit inward.
- The PASSENGER AIR BAG  indicator lamp in the upper part of the centre console lights up and turns off after about 60 seconds → page 43.



- Close the front passenger door.
- While the ignition is switched on, check that the PASSENGER AIR BAG  indicator lamp in the upper part of the centre console is *not* lit → page 43.

Disabling the front passenger front airbag

- Switch off the ignition.
- Open the front passenger door.
- Unfold the vehicle key bit → page 60.
- Using the key bit, turn the key-activated switch → Fig. 39 →  to  **OFF**.
- Remove the vehicle key from the key activated switch and fold the key bit inward.
- Close the front passenger door.
- The PASSENGER AIR BAG  indicator lamp in the upper part of the centre console is permanently lit while the ignition is on → page 43.

Disabled front passenger front airbag indicator

A disabled front passenger front airbag is indicated **exclusively** by the PASSENGER AIR BAG  indicator lamp permanently lit in the upper part of the centre console ( permanently-lit yellow light) → page 43.

When the PASSENGER AIR BAG  indicator lamp in the upper part of the centre console is **not permanently lit** or if it is lit together with the  indicator lamp on the instrument cluster, no child restraint system must be assembled on the front passenger seat for safety reasons. The front passenger front airbag could be triggered in an accident.

WARNING

The front passenger front airbag may only be deactivated in special cases.

- Switch the front passenger front airbag on and off only while the ignition is switched off to prevent damages to the airbag system.
- The driver is responsible for the correct positioning of the switch activated by the key.
- Disable the front passenger front airbag only when, under special circumstances, there is a child seat mounted on the passenger seat.
- Enable the front passenger front airbag again as soon as the child seat is no longer being used on the front passenger seat.

NOTICE

An insufficiently inserted key blade may get damaged when turning the key in the key activated switch.

NOTICE

Do not leave the vehicle key inserted into the key activated switch as this may cause damage to the door lining, to the dash panel, to the key activated switch and to the vehicle key when closing the front passenger door.

Side airbags

Please refer to  at the start of the chapter on page 42.

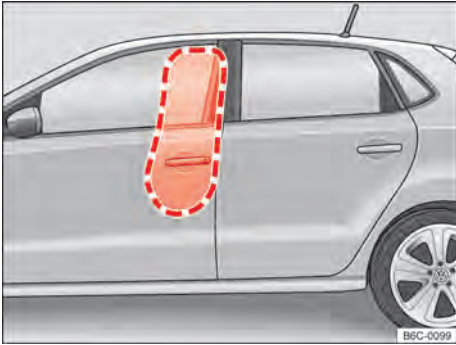

Fig. 40 On the left side of the vehicle: side airbag deployment zone.

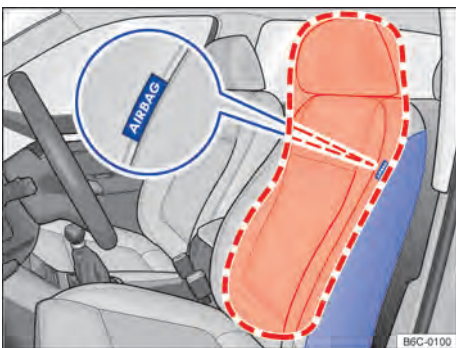



Fig. 41 Front seat side: installation location and deployment zone of the side airbags.

The side airbags are placed in the driver and front passenger seat's backrest outer padding → Fig. 41. Airbag installation locations are identified with the inscription "AIRBAG".

The red highlighted areas → Fig. 40 and → Fig. 41 are covered by the side airbags when triggered (deployment zones). For this reason, you must never leave or attach any items in these areas → .

In the case of a side collision, the side airbags on the collision side are triggered and thereby reduce the risk of injuries to the body parts turned towards the impact side of the vehicle's occupants.

WARNING

Once triggered, the airbag inflates at very high speed in a fraction of seconds.

- Always leave the deployment zones of the side airbags clear.
- People, animals or objects must never be in-between the vehicle's front seat occupants, the rear side seat occupants and the airbag expansion areas. Ensure this is also followed by children and passengers.
- Hang only light clothes on the vehicle's clothing hook. Do not leave any heavy or cutting objects in the pockets.
- Do not install accessories on the doors.
- Apply only seat or protective covers expressly released for use in the vehicle. Otherwise the side airbag may not insufflate when triggered.

WARNING

Inadequate handling of the front seats may prevent the side airbags from operating correctly and cause serious injuries.

- Never remove the vehicle front seats or alter parts thereof.
- When excessively high forces are applied to the side supports of the seats backrest, the side airbags may not operate correctly, may not operate at all or be accidentally triggered.
- Damages to the original seat covers or to the seams in the area of the side airbag modules must be checked immediately by a Volkswagen dealership.

Transporting children in the vehicle

Introduction

Child seats reduce the risk of injury in an accident. Always transport children in child seats, according to applicable laws!

Note:

- Child seats are grouped according to the child's size, age and weight.
- Installing child seats in the vehicle can be executed with different retaining systems.

For safety reasons child seats must preferably be mounted on the backseats → page 51, *Installation and child seat usage in the vehicle*.

Before transporting babies and children in child seats on the front passenger seat, it is imperative to read all airbag system information and learn about potential injuries airbag deployment can cause children in the 0 and 0+ group.

This information is very important for the safety of the driver and all passengers, especially babies and small children.

Volkswagen recommends using child seats from the Volkswagen Original Accessories Program. These child seats were developed and approved for use in Volkswagen vehicles.

WARNING

Children who are not strapped in or who are not strapped in properly could sustain severe or fatal injuries while the vehicle is in motion.

- Never leave a child seat facing backwards on the front passenger seat without disabling the airbag for risk of possible injuries from the triggered airbag.
- Volkswagen recommends to always transport children of age under 12 years or less than 1.50 m high on the rear seat.
- Always secure children in the vehicle with an authorised restraint system suitable to their height and weight.
- Always fasten children's seat belts or child seats, or secure all chairs transported to the ISOFIX system and ensure the proper sitting position.

- Ensure that the seat belt routing is correct for each use condition. If the seat belt must be passed over the child's body, ensure that the seat belt passes through the child's shoulder and never through the child's neck.
- Never allow children or babies to be transported on someone's lap, or while being held.
- Only ever fasten one child into each child seat.
- Read and observe the child seat's manufacturer instructions, especially regarding proper seat belt attachment.
- Replace child seats that withstand any force during an accident as they could have sustained damage that may not be visible.

WARNING

An unsecured, unoccupied child seat could be flung through the vehicle interior in the event of a sudden braking manoeuvre or accident. This could cause injuries.

- Always secure child seats safely, even if they are not being used, or have it safely stowed in the luggage compartment when driving.

Child seat types

Please refer to **WARNING** at the start of the chapter on page 49.

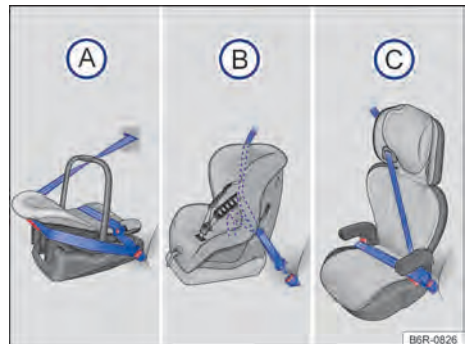

Fig. 42 Figures (A), (B) and (C) illustrate the main securing points for the child restraint system for children only wearing the seat belt.

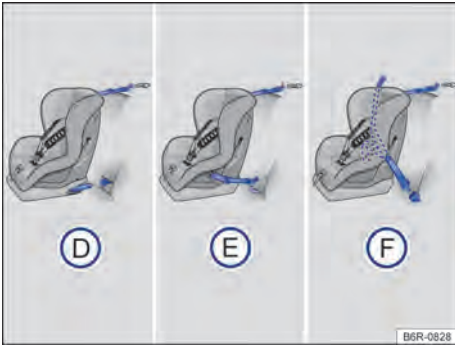

Fig. 43 On the rear seat: figures **D** e **E** illustrate the securing principle of the child retention system to the bottom retention eyes and the top tether. Figure **C** illustrates how to fasten the child restraint system with the vehicle seat belt and the top tether.

Always secure child seats properly, safely and in accordance with the installation instructions from the child seat manufacturer.

The mounted child seat must be secured by the vehicle's seat belts or the ISOFIX and Top Tether system and must not allow any longitudinal or transversal movement.

Country-specific standards for transporting children in vehicles

Child seats must conform to the ECE-R 44¹⁾ standard (Europe). Additional information can be obtained from your Volkswagen Dealership and online at www.volkswagen.com.

Country-specific securing systems

Child seat types → Fig. 42:

- (A)** Portable crib → baby convenience seat
- (B)** Child seat
- (C)** Lifting seat

The systems are made up of attachments for child restraint systems for children wearing the seat belt in the rear seat.

Fastening variants → Fig. 43:

- (D)** ISOFIX or i-Size retaining eyebolts and top fastening belt, type "Top Tether"
- (E)** Universal LATCH and "Top Tether" type securing belt.
- (F)** Automatic three-point seat belt and "Top Tether".

The systems show the securing of the child restraining system with a Top Tether securing belt and the bottom mounting points on the seat.

Group classification for child seats according to ECE-R 44

Weight class	Child's weight	Age
Group 0	up to 10 kg	up to approximately 9 months
Group 0+	up to 13 kg	up to approximately 18 months
Group 1	9 kg to 18 kg	approximately 8 months to 3 ¹ / ₂ years
Group 2	15 kg to 25 kg	approximately 3 to 7 years
Group 3	22 kg to 36 kg	approximately 6 to 12 years

In addition to age range, other aspects must be considered for child seat adjustment purposes, such as weight, height, and physical build of the child, since the child's biotype may not correspond to the majority of the population within the same age range. In case of doubts, please contact a Volkswagen Dealership.

Child seats that have been tested and approved under the ECE R 44 standard bear the test mark firmly on the seat: a capital E in a circle, below the test number.

Child seats by approval categories

Child seats can have the approval category "universal", "semi-universal", "vehicle-specific" (all according to ECE-R 44) or "i-Size" (according to ECE-R 129).

¹⁾ ECE Regulation: Economic Commission for Europe-Regelung

(Universal:) “universal” approved child seats are approved for installation in all vehicles. A template list is not required. With universal approval for ISOFIX, the child seat must be additionally secured using a top tether strap (Top Tether).

(Semiuniversal:) a “semi-universal” approval requires, in addition to the normal requirements for universal approval, safety devices to secure the child seat that require additional testing. Child seats with “semi-universal” approval have a list of models in which the vehicle must be contained.

(Específica do veículo:) a vehicle-specific approval requires, for each vehicle model, a dynamic test of the child seat in the vehicle, carried out separately. Child seats with “vehicle specific” approval also have a list of models.

(i-Size:) child seats with “i-Size” approval must meet the requirements laid down in the ECE-R 129 standard with regard to installation and safety. Consult the child seat manufacturer to find out which child seats are approved for that vehicle according to i-Size.



Legislation and legal requirements take precedence over the descriptions in this Owner's Manual.

Guidelines on the installation of a child seat

On the installation of a child seat, observe the following general guidelines. They are valid for all child seat securing systems.

- Read and follow the child seat manufacturer instructions → .
- Preferably mount the child seat on the rear bench seat behind the front passenger seat so that child may exit the vehicle on the sidewalk side.
- Disable the front passenger front airbag when mounting a child seat facing backwards on the front passenger seat.
- When mounting the child seat on the front passenger seat, position the front passenger seat fully back → page 32.
- Always leave sufficient clear space around the child seat. Adjust the seat in front of the child seat, if necessary. Observe and follow without fail the correct driver seat or front passenger seat position → page 32.
- The child seat backrest must fully rest against the vehicle seat backrest. Adjust the backrest position to have the child seat fully resting against it. Should the installed child seat touch the head restraint of the vehicle seat, preventing it from correctly resting on the vehicle's backrest, push the head restraint way up or remove and store it safely in the vehicle → page 77.

Installation and child seat usage in the vehicle

 Please refer to  at the start of the chapter on page 49.

The laws of physics, which come into force on a vehicle during a collision or any other kind of accident, also apply to children → page 34. In contrast to adults and teenagers, however, children's muscles and bones are not yet fully developed. Children have a higher risk for children of sustaining severe injuries in case of an accident.

Children must be transported using child restraint systems that are specifically suited to their size, weight and physical build, as children's bodies are not yet fully developed.

Country specific specifications

In relation to the use of child seats and their securing possibilities, there are divergent prescriptions and legal determinations in force in the different countries. Not all countries allow you to transport children on the front passenger seat.

Airbag sticker

In the vehicle there will exist stickers with important information on the front passenger front airbag. The content depends on the country and may vary. Check the sticker attached to the driver and/or front passenger sun visor.

Prior installing a child seat backwards it is imperative to observe the warnings → .

Hazards of transporting children on the front passenger seat

Not all countries allow you to transport children on the front passenger seat.

Exceptions provided to transport children in the front seat → .

- When the vehicle only has front seats.
- When the number of children below the age of 10 exceeds the rear seat capacity. In this case, children with greatest stature may be transported in the front seat, using the vehicle's seat belt or the appropriate securing system according to the child's age.

The triggering of the front passenger front airbag while using a **backwards installed child seat** may result in severe or fatal injuries → ⚠.

A backwards installed child seat on the front passenger seat is to be used only when the front passenger front airbag is disabled. A disabled front passenger front airbag is indicated by a PASSENGER AIR BAG OFF  warning light permanently lit on the centre console. Disabling the front passenger front airbag → page 47.

Do not disable the front passenger front airbag when using a **forward turned child seat**. When installing a child seat, adjust it to be as far as possible from the front passenger front airbag. The triggering of the front passenger front airbag may cause severe injuries → ⚠.

Not all child seats have been approved for use on the front passenger seat. The child seat must have been specially approved by the manufacturer for its use on the front passenger seat of vehicles with front and side airbags. Volkswagen Dealerships keep an up-to-date list of approved child seats.

Hazards related with side airbags

When triggered, the side airbag may hit the child's head and severely injure the child → ⚠.

DANGER

Never use child seats facing backwards in the front passenger seat while the front passenger airbag is activated. The child may be killed upon front airbag deployment, since the child seat is impacted with great strength and projected against the backrest.

DANGER

Using child seats backwards on the front passenger seat increases the risk of severe or fatal injuries to the child in case of an accident.

- Disabling the front passenger front airbag . If the front passenger front airbag cannot be disabled it is not permitted to use child seats turned backwards.
- Use only child seats approved by the child seat manufacturer for use on the front passenger seat with front and side airbag.

WARNING

Risk of injury with incorrectly installed child seats.

- Observe and follow the child seat manufacturer's installation instructions and warnings.

WARNING

Risk of injury when using a child seat turned frontward on the front passenger seat.

- Position the front passenger seat as far back as possible to ensure the child seat remains as far away as possible from the front passenger front airbag.
- Place the seat backrest in a vertical position that allows the child seat to fit in place.
- The seat belt height adjustment must be adjusted to the most adequate position for the height of the child or the child seat.
- Use only child seats approved by the child seat manufacturer for use on the front passenger seat with front and side airbag.

WARNING

In the event of an accident, the rear seat is the safest place for children with properly fastened seat belts.

- A suitable child seat, correctly fitted and used on one of the rear seats, will provide the maximum level of protection for children up to 12 years old in most accident scenarios.

WARNING

To prevent injuries from a triggered curtain or side airbag:

- Ensure that the child is not in the airbag's deployment zone → page 42, *Airbag system*.
- Do not place objects in the side airbag's deployment zone.



Attaching the child seat using the lower anchor points (ISOFIX, i-Size or LATCH)

📖 Please refer to ⚠️ at the start of the chapter on page 49.



Fig. 44 On the vehicle seat: identification of lower retaining rings for child seats.

The 2 retaining rings for each child seat equipped with ISOFIX system or i-Size can be accessed through the openings on the rear seat lining → Fig. 44.

ISOFIX installation overview

Depending on the size category **A** to **G** of the ECE-R 16¹⁾ European standard, the possibilities of installing child seats to the ISOFIX retaining system on the respective vehicle seats are listed in the following table.

	Group (weight class) of child seats with ISOFIX									
	Group 0: up to 10 kg		Group 0: up to 10 kg			Group 1: 9 kg to 18 kg				
			Group 0+: up to 13 kg			Rear-facing (opposite to the driving direction)		Front-facing (driving direction)		
Installation direction	Rear-facing (opposite to the driving direction)		Rear-facing (opposite to the driving direction)			Rear-facing (opposite to the driving direction)		Front-facing (driving direction)		
Size class	F	G	C	D	E	C	D	A	B	B1
Installation on the front passenger seat:	Seat without retaining rings; ISOFIX/LATCH fastening not available									
Installation in rear seats	IL-SU		IL-SU			IL-SU		IUF/IL-SU		

IL-SU: suitable seat to install child seats with ISOFIX, with "semi-universal" approval; refer to the list of vehicles of the child seat manufacturer.

IUF: suitable seat to install child seats with ISOFIX, with "universal" approval and Top Tether seat belt support.

Installing child seats with ISOFIX or i-Size

The installation location of the lower anchor points is marked with an ISOFIX symbol or an i-Size symbol.



Identification of ISOFIX anchorage points for child seats on rear seats.



Identification of i-Size anchorage points for child seats on rear seats.

Child seats with rigid attachment (ISOFIX or i-Size)

Guides can be used to install fixed-slot child seats, if provided along with the respective child seat. Guides assembled before the seat's coupling to the ISOFIX retaining rings facilitate the installation process and preserve the seat lining. Guides are locked in both of the vehicle's ISOFIX retaining rings → ①.

- Observe and follow the instructions → page 51, *Installation and child seat usage in the vehicle.*
- Follow the child seat manufacturer's instructions when installing or removing child seats → ⚠️.

¹⁾ ECE Economic Commission for Europe-Regelung

- If necessary, fold down the protective cover of the ISOFIX or i-Size anchor points.
- Fit the child seat onto the retaining rings → Fig. 44 in the direction of the arrow. The child seat must be safely and audibly (clicking sound) secured in place.
- Push the head restraint fully upwards or remove it altogether to prevent interference with the child seat → page 77.
- Perform a traction test in both sides of the child seat to ensure both locks are secured.

Child seat with adjustable tethers (LATCH)

- Observe and follow the instructions → page 51, *Installation and child seat usage in the vehicle*.
- Follow the child seat manufacturer's instructions when installing or removing child seats → .
- When fastening belts are provided along with the child seat, place the child seat on the seat surface and hook the fastening belt hooks to the retaining rings → Fig. 44.
- Push the head restraint fully upwards or remove it altogether to prevent interference with the child seat → page 77.
- Evenly stretch the fastening belts in the respective adjustment device. The child seat must be properly supported on the vehicle seat.
- Perform a traction test in both sides of the child seat to ensure both locks are secured.

WARNING

The lower child seat retaining rings must not be used as cargo strapping rings. Only secure appropriate child seats in the lower retaining rings.

- Only the fastening belts provided with the respective child seat must be used to secure child seats with adjustable tethers (LATCH). Adapted or improvised belts must never be used to secure child seats.

NOTICE

- In order to prevent permanent upholstery damages, the fixed-slot fitting guides (ISOFIX) must be removed from the retaining rings whenever the child seat is not installed to the vehicle's retaining rings.
- In order to avoid damages to fabrics, upholstery or guides, the fixed-slot fitting guides (ISOFIX) must always be removed from the retaining rings before folding the rear seat forward. 

Securing child seats with Top Tether

📖 Please refer to ⚠️ at the start of the chapter on page 49.



Fig. 45 retention eyes for the top tether on the back side of the rear seat.

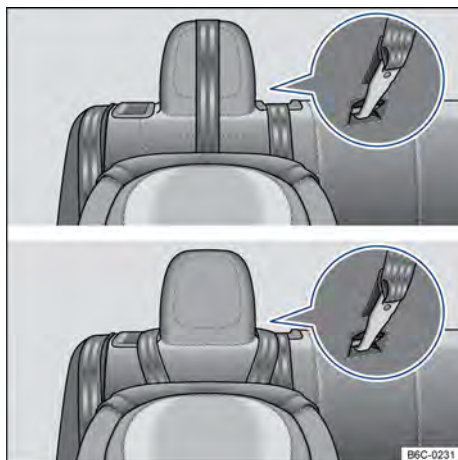

Fig. 46 On the rear seat backrest: [A] position of the seat belt laces in the case of non-adjustable head restraints with Top Tether individual belt, [B] position of the seat belt laces in the case of non-adjustable head restraints with V-shaped Top Tether belt.

Besides being secured to the ISOFIX anchoring points, ISOFIX child seats with universal approval must also be secured with a top tether.

Secure the top tether only to the appropriate retention eyes. The appropriate eyes for the top tether are identified by a symbol, and, if the case, by the inscription "TOP TETHER".

- Observe and follow the instructions → page 51, *Installation and child seat usage in the vehicle.*
- Follow the child seat manufacturer's instructions when installing or removing child seats → ⚠️.
- If possible, fully push up or remove the headrest to avoid interference with the child seat → page 77.
- Secure the child seat to the lower ISOFIX retaining rings → page 53. The child seat must be safely and audibly (clicking sound) secured in place.
- *For vehicles with the removable headrest:* Push the head restraint fully upwards or remove it altogether to prevent interference with the child seat → page 77.
- *For the Top Tether single-belt child seat with integrated headrest:* guide the Top Tether belt over the integrated headrest → Fig. 46 (A).
- *For V-shaped Top Tether seat belt child seat with integrated headrest:* guide the Top Tether belt sideways on the integrated headrest towards the rear → Fig. 46 (B).
- Stretch the tether until the child seat is supported on the upper part of the seat backrest.
- Install the luggage compartment cover → page 179.

Reinstall the headrest after installing the child seat → page 77.

⚠️ WARNING

Child seat with lower retaining rings and top tethers must be assembled as per the manufacturers' instructions. Otherwise, users may be subject to severe injuries.

- Always secure only *one* top child seat strap to one retaining ring in the luggage compartment.
- Always use appropriate retaining rings for the respective straps.
- Never secure straps to strapping eyelets.
- Only the belt provided along with the respective child seat (if available) must be used in the Top Tether. Adapted or improvised tethers cannot be used.

Securing child seats using the seat belt

📖 Please refer to ⚠ at the start of the chapter on page 49.

Universal child seats may be secured with the seat belt of seats indicated on the table with **u**. When such seats cannot be secured, an **X** is indicated.

Weight class	Child seat assembly direction	Front passenger seat		Rear side seats	rear central seat
		Front passenger airbag enabled	Front passenger airbag disabled		
Group 0 : up to 10 kg	Secured opposite to the driving direction	X	u	u	u
Group 0+ : up to 13 kg	Secured opposite to the driving direction	X	u	u	u
Group 1 : 9 to 18 kg	Secured opposite to the driving direction	X	u	u	u
	Secured in the driving direction	u	X	u	u
Group 2 15 to 25 kg	Secured in the driving direction	u	X	u	X
Group 3 22 to 36 kg	Secured in the driving direction	u	X	u	X

Securing child seats using the seat belt

- Observe and follow the instructions → page 51, *Installation and child seat usage in the vehicle*.
- Read and follow the instructions provided by the child seat manufacturer.
- If the child seat is assembled on the front passenger seat, push the front passenger seat as far back as possible and adjust the backrest to an upright position to comfortably fit the child seat.
- The seat belt height adjustment must be adjusted to the most adequate position for the height of the child or the child seat.
- Place the child seat over the seat and pass the seat belt as per the child seat manufacturer's instructions.

- Push the head restraint fully upwards or remove it altogether to prevent interference with the child seat → page 77.
- Ensure that the seat belt is not twisted.
- Insert the seat belt latch plate into the respective buckle until a "clicking" sound is heard.
- The seat belt must lie firmly and adequately over the child seat or the child.
- Conduct seat belt traction test – ensure that the lower belt strap is locked and can no longer be pulled out.

Removing child seats

Unfasten seat belts only when the vehicle is stationary → ⚠.

- Press the red button in the buckle. The latch plate is released and springs out.
- Guide the belt back by hand so that it rolls up easily, without twisting the seat belt and without damaging the trim.
- Remove the child seat from the vehicle according to the instructions given by the child seat manufacturer.

⚠ WARNING

Unfastening seat belts while the vehicle is in motion can lead to severe or fatal injuries in the event of an accident or sudden braking or driving manoeuvres.

- Unfasten seat belts only when the vehicle is stationary .

Childproof lock

📖 Please refer to **⚠** at the start of the chapter on page 49.

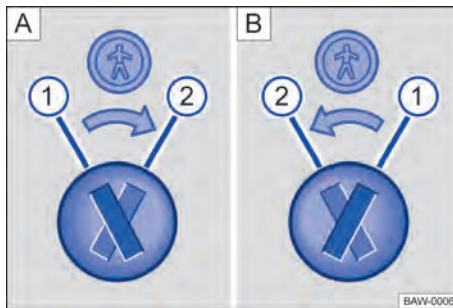

Fig. 47 Childproof lock: **A** rear left door, **B** rear right door.

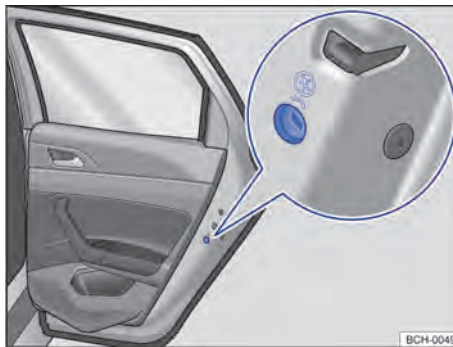

Fig. 48 On the rear door (right-hand side): childproof lock.

Key for → Fig. 47:

- ① Childproof lock disabled.
- ② Childproof lock enabled.

The childproof lock prevents the rear doors from being opened from the inside (e.g. so that children cannot open the doors accidentally while the vehicle is in motion).

When the childproof lock is activated the door can only be opened from the outside.

Enabling or disabling the childproof lock

- Unlock the vehicle and open the respective rear door.
- Fold the vehicle key blade out → page 60.
- Insert the key blade into the childproof lock groove to enable or disable the lock → Fig. 47.

⚠ WARNING

When the childproof lock is enabled, the door cannot be opened from the inside.

- Never leave unattended children or people with special needs in the vehicle with the doors locked. This may mean that these people lock themselves in the vehicle in case of emergencies. Locked individuals can be exposed to extremely high or low temperatures or lack of breathable air.
- Depending on the time of year, locked vehicles can be subjected to extremely high or low temperatures. This can cause serious injuries and illness or fatalities, particularly for small children.

In an emergency

Making you and your vehicle safe







Fig. 49 On the upper portion of the centre console: warning lamp switch.

Observe any legislation concerning the safety of a broken down vehicle. For example, many countries stipulate that you have to switch on the hazard warning lights → page 59.

Checklist

To ensure your own safety and the safety of your passengers, observe the following points in the order given → :

1. Stop the vehicle at a safe distance away from moving traffic and on a suitable surface → .
2. Switch on the hazard warning lights with the  → Fig. 49 button.
3. Apply the handbrake → page 120.
4. Vehicles with manual gearbox: move the gear shift lever into the neutral position → page 110.
5. Vehicles with automatic gearbox: position the selector lever to **P** → page 111.
6. Stop the engine and remove the key from the ignition lock → page 104.
7. Ensure that all occupants exit the vehicle away from moving traffic and proceed to a safe position, e.g. behind the guardrail.
8. Take all vehicle keys with you when you leave the vehicle.
9. Place the warning triangle in position to draw the attention of other road users to your vehicle.
10. Allow the engine to cool down and, if necessary, seek expert assistance.

When the hazard warning lights are switched on, all turn signals flash at the same time. The turn signals   and an indicator light at the switch  flash at the same time. The hazard warning lights also work when the ignition is switched off.

Lit indicator lights could indicate a change in direction or lane while towing or by activating the turn signal lever. The indicator lights are temporarily interrupted.

Examples in which hazard warning lights must be switched on:

- When traffic ahead suddenly starts moving more slowly or you reach the tail end of a traffic jam. This will warn vehicles behind you.
- When there is an emergency.
- When the vehicle breaks down.
- When being towed.

Always follow local regulations for the use of the hazard warning lights.

If the hazard warning lights are not working, use an alternative method of drawing attention to the broken down vehicle (according to applicable legal provisions).

Emergency brake lights - ESS (Emergency Stop Signal)

For vehicles with ESS function and anti-lock brake system (ABS), during sudden and continuous braking at speeds greater than 80 km/h, the brake light lamp may flash to warn cars coming in from behind.

If the braking manoeuvre is further extended, maintaining the same deceleration rate, the warning lights are automatically activated and flash when the vehicle reaches a speed lower than approximately 10 km/h. Upon resuming vehicle movement, warning lights are automatically deactivated.

Warning lamps may also be switched off via the  dash panel → Fig. 49 switch.

WARNING

Broken-down vehicles lacking due signalling increase the risk of accidents both for you and for other road users.

- Stop the vehicle as soon as possible in a safe location. ▶

- Park the vehicle at a safe distance from moving traffic in order to lock all doors securely in an emergency.
- Switch on the hazard warning lights and set up the warning triangle to warn other road users.
- Never leave unattended children or people with special needs in the vehicle with the doors locked. This may mean that they are locked in the vehicle in an emergency. Persons locked in the vehicle may be exposed to extremely high or low temperatures.

⚠ WARNING

Ignoring any of the points on this important safety checklist can lead to accidents and injuries.

- Always follow the instructions on the checklist and comply with applicable safety precautions.

⚠ WARNING

The components of the exhaust system become very hot. This can cause fires and serious injuries.

- Never park the vehicle so that parts of the exhaust system can come into contact with inflammable material underneath the vehicle, e.g. dry grass, fuel, etc.

i The vehicle battery will discharge if the hazard warning lights are left on over a long period of time – even if the ignition is switched off.

i Whenever airbags are activated in accidents, warning lights may be automatically activated → page 45.

Emergency equipment

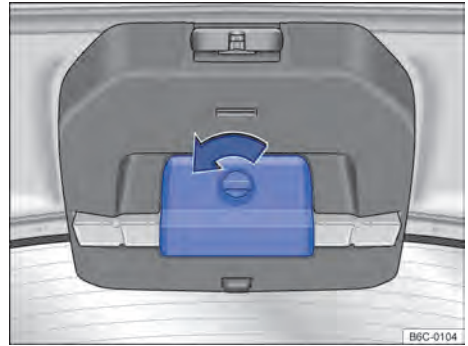

Fig. 50 On the rear lid: warning triangle holder.

Warning triangle

The warning triangle may not be available for some export markets.

With open boot lid, rotate the holder cover by 90° counter-clockwise → Fig. 50 (arrow), fold the holder downward and remove the warning triangle.

After use, fit the warning triangle back into the holder and close it.

Fire extinguisher

The fire extinguisher may not be available for some export markets.

According to the vehicle version, the fire extinguisher support may be situated in the footwell under the front passenger seat.

The fire extinguisher must correspond to the legal requirements, be always ready for use, and be regularly inspected (see the inspection seal on the fire extinguisher).

⚠ WARNING

Loose objects may be projected inside the vehicle in the event of a sudden driving or braking manoeuvre, as well as during accidents, and may cause severe injuries.

- Secure the warning triangle in the respective straps.

i The warning triangle must comply with applicable legal provisions in each country. ◀

Open and close

Vehicle key

Vehicle key functions

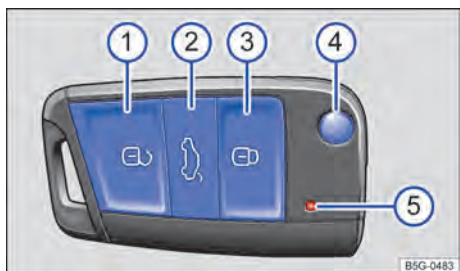

Fig. 51 Vehicle key with remote control.

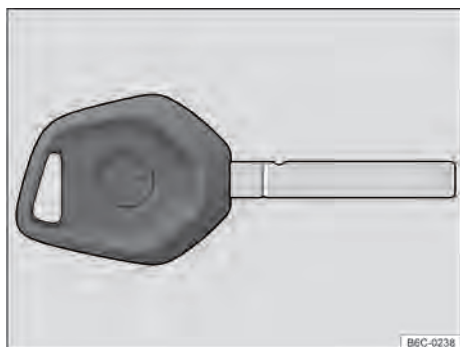

Fig. 52 Mechanical key.

Key for → Fig. 51:

- ① Central locking button: unlock the vehicle.
- ② Unlock the rear lid separately.
- ③ Central locking button: lock the vehicle.
- ④ Folding and unfolding the key blade.
- ⑤ Indicator lamp: flashes after pressing the button.

Locking or unlocking the vehicle from the outside

If it is necessary to unlock or lock the vehicle from the outside using the vehicle key with remote control through the door lock cylinder, remove the cover cap → page 66.

- **Unlock:** press . Keep pressed for convenience opening. **OR:** insert the vehicle key into the driver door lock cylinder and turn **counterclockwise**.
- **Lock:** press . Press and hold for comfort closure. **OR:** with the stem of the vehicle key, insert it into the driver's door lock cylinder and turn in **clockwise**.
- **Unlock the boot lid:** press the button → page 69. **OR:** insert the vehicle key into the driver door lock cylinder and turn **counterclockwise**. The rear lid is unlocked.
- **Lock:** all lights flash *once* to confirm.
- **Unlock:** all lights flash *twice* to confirm.

Note: according to the central locking function setting on the radio system → page 28, all doors and the boot lid will only be unlocked after the button is pressed for the second time.

It is possible to enable/disable the sound signal (horn) of the alarm activation/deactivation confirmation. Depending on the vehicle version, the radio version, and whether it has (or not) an alarm system:

- On the radio (variant 1), through the button .
- On the **Vehicle configuration** menu, enable or disable the sound confirmation → page 28.
- **OR**
- On the radio (variant 2), through the settings button .
- Touch the function button.
- On the **Open and close** menu, enable or disable the sound confirmation → page 28.

For the remaining vehicles go to a Volkswagen dealership to enable/disable the audible confirmation.

WARNING

Improper or unsupervised use of the vehicle keys can cause severe accidents or injuries.

- Always take all vehicle keys with you every time you leave the vehicle. Children or unauthorised persons could lock the doors and boot lid, start the engine, switch on the ignition and thus operate electrical equipment, such as the electric windows.
- Never leave unattended children or people with special needs in the vehicle. They could become trapped in the vehicle in an

emergency and may not be able to get themselves to safety. Depending on the time of year, for example, locked vehicles can be subjected to very high or very low temperatures. This can cause serious injuries and illness or fatalities, especially for small children.

- Never remove the vehicle key from the ignition lock when the vehicle is in motion.

NOTICE

Every vehicle key contains electronic components. Protect the key from damage, moisture and excessive vibration.

 Press the buttons on the key only when the corresponding function is actually needed. Unnecessary activation of the button can cause an unintentional unlocking or triggering of the vehicle alarm (if the vehicle is equipped with the alarm system). This also applies when it is believed to be beyond the effective range.

Replacing the battery

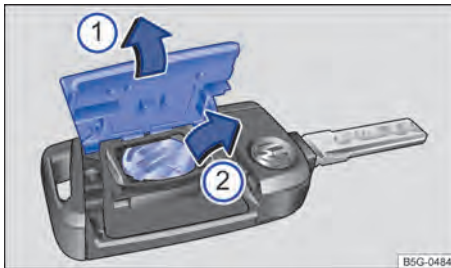

Fig. 53 Vehicle key: replacing the battery.

Key for → Fig. 53:

- ① Remove the cover.
- ② Remove the battery.

Volkswagen recommends having the battery changed by a Volkswagen Dealership.

- Fold the vehicle key blade out.
- Remove the cover ① in the direction of the arrow → ①.
- Remove the battery from the battery compartment using an appropriate tool ②.

- Position the new battery and push it in the opposite direction to the arrow ② into the battery compartment → ①.
- Press the cover in the opposite direction of the arrow ① onto the vehicle key housing until it engages.

⚠ DANGER

Should 20 mm diameter batteries or other lithium batteries be swallowed, severe or even fatal injuries may result within a short period of time.

- Always keep the vehicle key, key ring with batteries, spare batteries, round cells and other batteries out of the reach of children.
- Seek medical assistance immediately if you suspect someone has swallowed a battery.

NOTICE

- The vehicle key may be damaged if the battery is improperly changed.
- Unsuitable batteries may damage the vehicle key. Discharged batteries should only be replaced with new batteries of the same voltage rating, size and specification.
- Ensure that the battery is fitted the right way round.

 The batteries contain toxic substances. This product cannot be disposed / discarded along with common trash. There are specific legal requirements regarding the disposal / discarding of used batteries. For your safety and convenience, Volkswagen recommends replacing the battery only at a Volkswagen Dealership.

Synchronize the vehicle key

When it is impossible to unlock or lock the vehicle with the vehicle key, synchronize the vehicle key or replace the battery → page 61.

- Fold the vehicle key blade out.
- Remove the protective driver side door handle cover → page 66.
- Press the vehicle key button . Meanwhile, remain next to the vehicle.

- Use the key bit to open the vehicle within one minute. The synchronization process will be completed.
- Reinstall the protective driver side door handle cover. ◀

Troubleshooting

Vehicle cannot be locked or unlocked

The remote control vehicle key may be temporarily disabled due to obstacles, bad weather conditions, weak battery, or excessive transmitters operating in the same frequency range near the vehicle (e.g. mobile phones or transmitters).

OR: if the buttons in the vehicle key or one of the central locking buttons are pressed repeatedly within a short period of time, the central locking system will switch off briefly to prevent overloading. The vehicle will then be unlocked. Lock the vehicle if necessary.

The indicator lamp does not flash

When the indicator lamp of the vehicle key does not flash, this may indicate that the battery or the key itself must be replaced → page 61.

Spare key

To acquire a key for the vehicle, the vehicle identification number is required.

Several vehicle keys may be valid for a vehicle.

New vehicle keys can be obtained at a Volkswagen Dealership.

Keyless locking and starting system "Keyless Access"

Introduction

Depending on the vehicle version, the Keyless Access locking and starting system may not be available.

The Keyless Access locking and starting system enables that the vehicle be unlocked and locked without the active use of the key. For such, a valid vehicle key must be located near the vehicle. ◀

Unlocking or locking the vehicle with Keyless Access

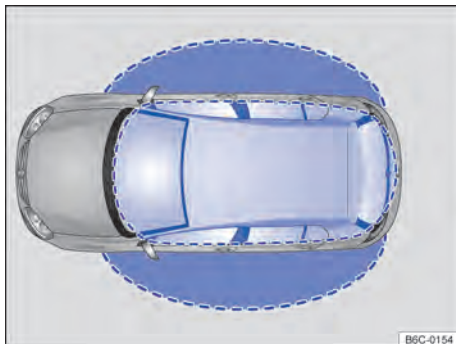

Fig. 54 Keyless Access: proximity areas.

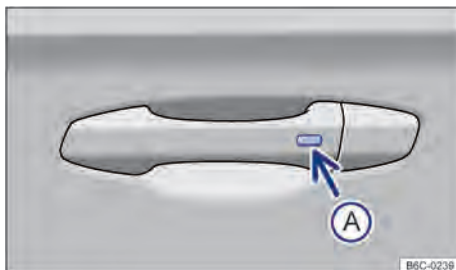

Fig. 55 On the door handle: button to unlock or lock.

Ⓐ Button on the outside of the door handle.

Unlocking the vehicle

- ① Press the button → Fig. 55 Ⓐ on the outside of the door handle.



Locking the vehicle

- ① Park the vehicle and switch off the ignition.
- ② Press the button → Fig. 55 Ⓐ on the outside of the door handle.

Unlocking is indicated by a *double* flash of all the turn signals, locking is indicated by a *single* flash.

Disable the Keyless Access temporarily

So that unauthorized third parties do not unlock and start the vehicle improperly, it is possible to temporarily deactivate the Keyless Access unlocking function: ▶

- Lock the vehicle with the  button on the vehicle key.
- Within 5 seconds, press the button on the outside of the door handle → Fig. 55 . So, don't grab the door handle. The Keyless Access locking and starting system is temporarily disabled.
- The Keyless Access is temporarily disabled.
- To confirm the system is disabled, wait at least 10 seconds and pull the door handle. The door must not open.

The vehicle can only be unlocked with the vehicle key the next time it is unlocked. After the next unlocking the Keyless Access is again enabled.

Configure Keyless Access

Depending on the radio version, Keyless Access can be configured in the menu **Car** from the radio.

Keyless Access can be configured in two ways:

- **Single door:** by pressing the button once, only the respective door is unlocked. When pressed again, all doors are locked.
- **All doors:** By pressing the button once, all doors are unlocked. When pressed again, all doors are locked.

NOTICE

For vehicles with the Keyless Access function, when the central locking is already activated and the vehicle key is accidentally left inside the luggage compartment, upon closing the boot lid, it locks and automatically unlocks again.

 With a low or flat vehicle or key battery, the vehicle may possibly not be unlocked or locked by means of the Keyless Access. The vehicle may be manually unlocked or locked → page 67.

 To make it possible to control a successful locking of the vehicle, disable the unlocking function for a few seconds.

 A vehicle with automatic gearbox can only be locked when the selector lever is in the **P** position.

Troubleshooting

Keyless Access does not work

Volkswagen recommends looking for a Dealership Volkswagen or a specialized company.

 If on the display of the instrument cluster the message **Keyless defective** is displayed, Keyless Access operation failures may occur. Contact a Volkswagen Dealership.

 If no valid vehicle key is inside the vehicles interior, or if same is not recognized, a corresponding message will be displayed on the instrument cluster display. This may be the case when the vehicle key suffers interference from another radio signal or when covered by another object, for example, an accessory for mobile devices or an aluminium suitcase.

Central locking button and doors

Introduction

The doors and boot lid can be manually locked and partially unlocked, for example, when the vehicle key or central locking system fails.

The central locking locks all the doors and the boot lid. The vehicle *cannot* be locked with the driver door open.

The vehicle can only be locked when the ignition is turned off or when the driver leaves the vehicle with the engine turned off.

A symbolic representation → page 13 on the instrument cluster display indicates that one or more doors are not closed.  **Stop driving!** Open the respective vehicle door and close it again.

These symbols are also visible when the ignition is switched off. The indicator turns off a few minutes after the vehicle is locked with the doors closed.

WARNING

Doors that are not closed properly can open suddenly while the vehicle is in motion and may cause severe injuries.

- In this case, stop the vehicle immediately and close the door.
- Ensure that the door is closed properly and that the lock has engaged.
- Doors must only be opened or closed after ensuring there is nothing or no one is in its path.

WARNING

Doors that are being held open by the door check may close in strong winds or if the vehicle is on a slope, which may result in injuries.

- Always keep a good grip on the handle when opening and closing doors.

WARNING

The path of the doors is a dangerous area and may cause injuries.

- Doors should only be opened or closed when you are sure that nobody is in their path.

WARNING

An emergency closing or opening of the doors without sufficient care may result in severe injuries.

- When the vehicle is locked from the outside, it is not possible to open the doors and the electric windows from the inside.
- Never leave unattended children, animals or people with special needs in the vehicle. They could become trapped in the vehicle in an emergency and may not be able to get themselves to safety.
- Depending on the time of year, for example, locked vehicles can be subjected to very high or very low temperatures. This can cause serious injuries and illness or fatalities, especially for small children.

WARNING

Improper use of the central locking system could cause serious injuries.

- The central locking system locks all doors. Locking the vehicle from the inside may prevent the doors from being opened unintentionally and unauthorised persons from entering the vehicle. However, locked doors can delay assistance to passengers inside the vehicle in the event of an accident or emergency.

- Never leave unattended children or people with special needs in the vehicle. All doors can be locked from the inside using the central locking button. This may mean that people lock themselves in the vehicle. Persons locked in the vehicle may be exposed to extremely high or low temperatures.
- Depending on the time of year, locked vehicles can be subjected to extremely high or low temperatures. This can cause serious injuries and illness or fatalities, particularly for small children.
- Never leave anyone inside a locked vehicle. They could become trapped in the vehicle in an emergency and may not be able to get themselves to safety.
- Open and close doors and the boot lid only when there is no one near its opening/closing range.

NOTICE

When carrying out an emergency opening or closing procedure, remove and install parts carefully in order to avoid damage to the vehicle. 

Driver door indicator lamp

 Please refer to  and  at the start of the chapter on page 63.



The central locking indicator lamp is located in the driver door → page 9.

The vehicle locks: the red LED flashes for about two seconds in short intervals, then more slowly. The indicator lamp does *not* flash, when the vehicle was locked with the locking button of the central locking system in the driver door → page 65. 

Automatic locking and unlocking

 Please refer to  and  at the start of the chapter on page 63.

The central locking system enables you to lock and unlock all doors, the boot lid and the tank flap. 

Depending on the vehicle and radio version, central locking settings can be set in the radio system with the button  OR with the settings button  and touch the function surface  → page 28.

Automatic locking (Auto Lock)

The vehicle locks automatically upon reaching a speed of approximately 20 km/h. When the vehicle is locked, the indicator lamp  on the central locking button will shine in yellow.

Automatic unlocking (Auto Unlock)



When one of the following condition occurs, all the doors and the boot lid are automatically unlocked:

- The vehicle is stopped and the vehicle key has been removed (*only for vehicles without Keyless Access*).
- **OR:** the vehicle is stationary and the  button was pressed.
- **OR:** the door handle was activated to open the door.
- **OR:** the airbags were triggered in an accident → page 45.

The automatic unlocking enables the access of rescuers to the interior of the vehicle.

A vehicle with automatic gearbox can only be locked when the selector lever is in the **P** position. <

Key for → Fig. 56:

-  Unlocks the vehicle.
-  Lock the vehicle.

The central locking button works either with the ignition on or off, only when all doors are closed.

If the vehicle is locked from outside with the remote control vehicle key or through the driver door with the mechanical key, the central locking button will not work.

If the vehicle was locked from the inside with the central locking button, then:

- The indicator lamp  on the button lights up in yellow when all the doors and the boot lid are closed.
- The anti-theft alarm system is **not** activated (if the vehicle is equipped with the alarm system).

The doors can be opened from the inside by pulling the door handle. The indicator lamp  on the button turns off. The doors that were not opened, as well as the boot lid, remain locked and may not be opened from the outside. <

Central locking button

 Please refer to  and  at the start of the chapter on page 63.



Fig. 56 On the driver door: central locking button.

Closing or opening the driver door in case of emergency

📖 Please refer to ⚠ and ⚠ at the start of the chapter on page 63.

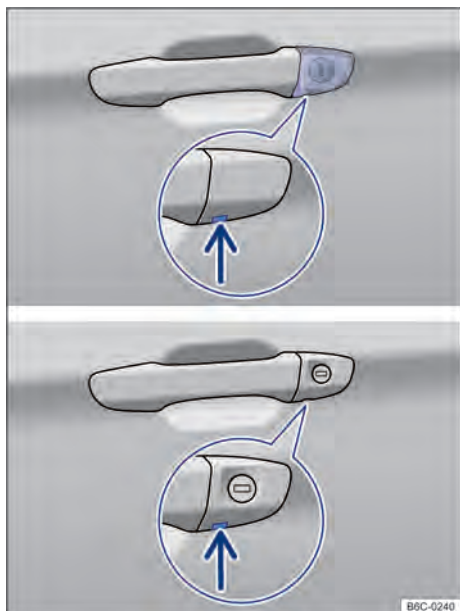

Fig. 57 Driver's door handle: lock cylinder.

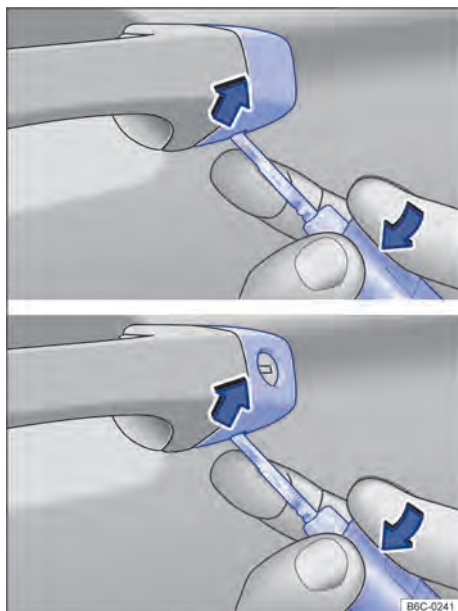

Fig. 58 Driver's door handle: remove cover.

All doors are usually locked when manually locking the door. Only the driver door is manually unlocked. Observe the anti-theft alarm instructions → page 63.

- Unfold the vehicle key bit → page 60.
- Insert the key blade from underneath into the cover opening → Fig. 57 (arrow).
- Keep the index finger underneath the key blade.
- Lift the cover cap with the vehicle key in the direction indicated by the arrow → Fig. 58.
- Insert the key blade into the lock cylinder and lock/unlock the vehicle.
- Pull the door handle and put the cover cap back on again.

Particularities of manual unlocking

- The anti-theft alarm remains enabled in the unlocked vehicle. However no alarm is triggered → page 64.
- The alarm is triggered immediately after opening the driver's door. ▶

- Upon turning on the ignition, the electronic immobiliser recognizes a valid vehicle key and disables the anti-theft alarm.
- After unlocking an emergency start must be performed → page 107.

i The anti-theft alarm is activated after manually locking the vehicle with the key blade → page 64.

By unlocking the vehicle or by opening the respective door from the inside, the manually locked door is again unlocked.

i The doors can be unlocked and opened from inside by pulling the door release handle.

Locking the front passenger door and rear doors in case of emergency

📖 Please refer to **⚠** and **🔔** at the start of the chapter on page 63.

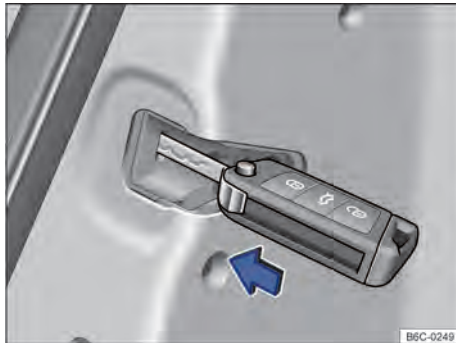

Fig. 59 On the doors, front right and rear: emergency locking of the vehicle with the metallic stem of the key.

The front passenger door and the rear doors can be manually locked. The anti-theft alarm system will **not** be activated.

- Open the door.
- Remove the rubber seal from the front of the door.
- Insert the metal shaft of the wrench into the slot → Fig. 59 and press.
- Fix the rubber seal again.
- Close the door completely.
- Check if the door is locked.
- Repeat this process in other doors, if necessary.

Troubleshooting

📖 Please refer to **⚠** and **🔔** at the start of the chapter on page 63.

Indicator lamp of the driver door permanently on

The LED light on the driver door flashes at short intervals and thereafter remains lit for about 30 seconds, flashing again thereafter.

The locking system is malfunctioning.

- Contact a Volkswagen Dealership.

The doors and boot lid can be manually unlocked or locked when the vehicle remote control key or central locking system → page 66 e → page 71 fails.

Turn signals do not flash

When the turn signals do *not* flash to confirm the locking of the vehicle:

- At least one of the doors or the boot lid is not shut.
- **OR:** in the convenience closing function not all the door windows are closed.

Vehicle automatically locked

When one of the following conditions is applied, the vehicle locks itself automatically after about 30 seconds.

- The vehicle was unlocked but not opened.
- The ignition was not turned on.
- The boot lid was not opened.

Procedure when locking with a second vehicle key

Keyless Access: the vehicle key that is inside the vehicle is blocked against engine starting as soon as the vehicle is locked from the outside by a second vehicle key. Press the **🔑** button on the vehicle key left inside the vehicle to enable it to start the engine → page 104.

Locking the vehicle after airbag deployment

The entire vehicle is unlocked when the airbags are triggered during an accident. Depending on the level of damage, the vehicle may be locked as follows after an accident:

- Switch off the ignition.
- Open and close one of the doors once.
- Remove the key from the vehicle and close → page 60.
- **OR:** press the central locking  button in the driver door → page 65.

 With a low or flat vehicle or key battery, the vehicle may possibly not be unlocked or locked by means of the Keyless Access. The vehicle may be manually unlocked or locked → page 66.

 If no valid vehicle key is inside the vehicles interior, or if same is not recognized, a corresponding message will be displayed on the instrument cluster display. This may be the case when the vehicle key suffers interference from another radio signal or when covered by another object, for example, an accessory for mobile devices or an aluminium suitcase.

Anti-theft alarm system

According to the vehicle version, the anti-theft alarm system may not be available.

The anti-theft alarm system is automatically engaged when locking the vehicle with the vehicle key or by touching the door sensor, for vehicles with Keyless Access.

The anti-theft alarm emits audible warning signals for about 25 seconds (per event) and visual warning signals for up to 5 minutes when the following non authorized actions are executed to the locked vehicle:

When does the system trigger an alarm?



- A door is opened.
- The engine compartment cover is opened.
- The boot lid is opened.
- Turning the ignition on with a non-valid vehicle key.

- One of the windows is removed, broken or opened.
- Movement inside the vehicle, for vehicles with interior movement monitoring system → page 68.

Switching off the alarm

- Unlocking the vehicle with the  unlocking button of the vehicle key.
- **OR:** turning the ignition on with a valid vehicle key. A brief alarm may occur for about a second.
- On vehicles with Keyless Access, the alarm can also be disabled by touching the door handle → page 62.

 The alarm goes off once again if, after the previous trigger, a new attempt to break into the same vehicle area or another protected area occurs.

 The anti-theft alarm system is **not** activated by locking the vehicle from inside with the central locking button .

 When the driver door is mechanically unlocked with the key, only the driver door is unlocked, not the entire vehicle. The central locking button is only enabled after the ignition is switched on, after which all doors can be electrically unlocked.

 The anti-theft alarm will not function correctly if the vehicle battery is weak or discharged.

Interior monitoring system

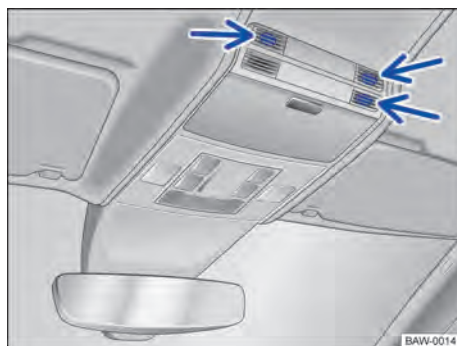





Fig. 60 On the roof console: vehicle interior monitoring sensors (arrows).

When movement is detected in the interior of a locked vehicle with enabled anti-theft alarm, the alarm is triggered and goes off → Fig. 60.

Switching on the interior monitoring system

Lock the vehicle using the remote control or mechanical vehicle key. When the anti-theft alarm is switched on, the interior monitoring system is also activated.

Temporarily disabling the vehicle interior monitoring system

- Switch on the ignition.
- Disable the vehicle interior monitoring system in the radio system button  OR selection button , touch the function surface  on the **Open and close** menu → page 28, depending on the vehicle and radio versions.
- Close all doors and the boot lid.
- Lock the vehicle with the vehicle key.

The vehicle interior monitoring system is disabled until the next vehicle locking.

Under the following situations it is advisable to disable the vehicle interior monitoring:

- When the vehicle needs to be carried.
- When the vehicle is transported.
- When the vehicle needs to be towed with suspended axle.
- When the vehicle needs to be put in an automatic vehicle washing system.

Risk of false alarm

The vehicle interior monitoring only works with the vehicle completely shut. Legal provisions must be followed. An alarm failure may occur under the following situations:

- If a window is fully or partly open.
- When easily moving items such as loose sheets of paper or mirror decoration items (e.g. air-fresheners) are left in the vehicle.
- If a mobile telephone that is left in the vehicle vibrates.



A permanent disabling of the vehicle interior monitoring is not possible.



When upon enabling the anti-theft alarm the doors or the boot lid are still open, only the anti-theft alarm will be enabled. Only after the closing of the doors and of the boot lid the vehicle interior monitoring is also enabled.

Boot lid

Introduction

The boot lid is locked and unlocked together with the doors.

WARNING

Incorrect and unsupervised unlocking, opening or closing of the boot lid can cause accidents and severe injuries.

- The boot lid must only be opened or closed after ensuring there is nothing or no one is in its path.
- Under no circumstances is the rear lid to be closed with the hand on the rear window. The rear window may splitter and cause injuries.
- After closing the boot lid, check to make sure that it is closed and locked correctly so that it does not open while the vehicle is in motion. The closed boot lid must be flush with the body panels.
- Always keep the boot lid closed while the vehicle is in motion so that no toxic exhaust fumes enter the vehicle's interior.
- Never open the boot lid when there is a load secured to it such as bikes. An open boot lid may lower due to additional weight. If necessary, support the boot lid or remove the additional load.
- Close and lock the boot lid and all vehicle doors when the vehicle is not in use. Ensure that no one remains in the vehicle.
- Never leave children playing unattended in or around the vehicle, especially when the boot lid is open. Children could climb into the luggage compartment and shut the boot lid, trapping themselves inside. Depending on the time of year, locked vehicles can be subjected to extremely high or low temperatures. This can cause serious injuries and illnesses or fatalities, particularly for small children.

- Never leave unattended children or people with special needs in the vehicle. All doors can be locked from the inside using the central locking button. This may mean that people lock themselves in the vehicle. Persons locked in the vehicle may be exposed to extremely high or low temperatures.

NOTICE

Before opening the boot lid, check whether there is sufficient space to open and close the boot lid (e.g. when parked in garages).

NOTICE

Never use the rear window wiper or the rear spoiler to secure loads or to hold on to. This may result in damages and may rip off the wiper or spoiler.

Opening and closing the boot lid



Please refer to  and  at the start of the chapter on page 69.



Fig. 61 On the centre console: boot lid release tab.

If, for instance a bicycle is installed on the boot lid luggage holder the boot lid cannot be opened → . Always remove items attached to the luggage holder before opening the boot lid and support the open boot lid.

Opening the boot lid

- To unlock the boot lid press the vehicle key  button.
- **OR:** in the centre console, press and hold  → Fig. 61 for a few seconds.
- **OR:** depending on the vehicle and radio versions, on the radio display touch the button  for a few seconds.

Closing the boot lid

- Pull the boot lid by its handle recess in the interior lining downward so it engages the lock → .

When the doors are locked the boot lid is also locked.

An icon on the instrument cluster display → page 13 indicates when the boot lid is not properly shut.

The boot lid is automatically locked when the vehicle is moving.

WARNING

Incorrect and unsupervised unlocking or opening of the boot lid can cause accidents and severe injuries.

- With a luggage holder attached over the boot lid, an unlocked boot lid is not always recognized. An unlocked boot lid might suddenly open while driving.

WARNING

Incorrect and unsupervised locking of the boot lid can cause accidents and severe injuries.

- When closing the rear lid, watch your hands keeping them out of reach of the closing sweep of the rear lid.

 If the boot lid is not opened within a few minutes after its unlocking it will be automatically locked again.

Emergency boot lid unlocking

📖 Please refer to ▲ and ⌚ at the start of the chapter on page 69.

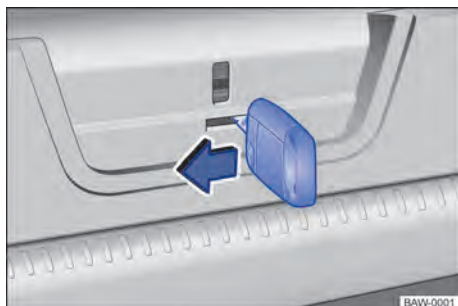

Fig. 62 In the luggage compartment: unlock the boot lid.

- Fold the rear seat backrest forwards → page 75.
- Remove luggage items in order to reach the boot lid from the vehicle interior.
- Unfold the vehicle key bit → page 60.
- Insert the key blade into the opening in the boot lid → Fig. 62 and move the release lever in the direction indicated by the arrow.

Troubleshooting

📖 Please refer to ▲ and ⌚ at the start of the chapter on page 69.

The boot lid cannot be opened or closed

Check if something is blocking the boot lid. It must be possible to move the boot lid by hand. This may require additional force.

Windows

Open or close windows

Manually opening or closing the windows

In vehicles *without electric windows*, activate the handle located in the internal door lining to open or close windows.

Electric opening or closing the windows

The buttons are located on the doors → page 9.

- 🔌 Opening the window: press the button.
Closing the window: pull the button.
- 🔌 Press to disable the rear door electric windows operating buttons.

The windows can still be operated using the door buttons for a brief period after the ignition has been switched off, provided the driver or front passenger door is not opened.

Depending on the vehicle version and equipment items, the convenience opening/closing and automatic closing features may not be available, vary in functions, or only be partially available.

One-touch opening and closing

The one-touch opening and closing function makes it possible to fully open and close the windows with a single touch. With this function it is not required to hold the Individual button pressed while fully opening or closing the window.

One-touch closing: pull the respective window button upwards to its second stage.

One-touch opening: press the respective window button downward to its second stage.

- ◀ **Interrupting the one-touch action:** press or pull the respective window operating button once again.



Convenience opening and closing

Depending on the vehicle version and equipment items, the convenience opening/closing and automatic closing features may not be available, vary in functions, or only be partially available.

Depending on the vehicle version, windows can be opened and closed from the outside using the vehicle key with the ignition off:

- ◀ – Press and hold unlock button (🔓) or lock button (🔒) on the vehicle key. All electric windows are opened or closed.
- *Closing in vehicles with Keyless Access locking and starting system:* press the door handle button → Fig. 55 for the lock.
- To stop the functions, release the unlock button or the lock button on the vehicle key OR release the key.

For this a valid vehicle key must be in the area of approach. Once all windows are shut the turn indicator lamps will flash *once*, in confirmation. ▶

Depending on the vehicle and radio version, different settings can be configured for operating the windows on the radio system, with the button  OR with the settings button  and touch the function surface  → page 28.

WARNING

Improper or careless use of the electric windows may cause severe injuries.

- Electric windows must only be opened or closed when you are sure that nobody and nothing is in their operating area.
- Never leave children or people who require special assistance unsupervised in the vehicle when the vehicle is locked.
- Always take all vehicle keys with you every time you leave the vehicle. After switching the ignition off and while the driver or front passenger door is not opened, the windows can still be operated for a brief period using the door buttons.
- When transporting children on the rear seats, always disable the rear electric windows using the safety button so they cannot be operated.

NOTICE

Rain water can enter the vehicle interior and damage the vehicle.

 The one-touch and roll-back functions will not work if there is a fault in the electric windows. Visit a Volkswagen Dealership or qualified workshop.

Roll-back function for the electric windows

The roll-back function for the electric windows can reduce the risk of injuries when the windows are closing.

When the one-touch closing operation of a window encounters a difficulty of movement because it is stiff or obstructed, the window will automatically open again → .

- Check to see why the window has not closed.
- Try to close the window again.
- After a few repeated activations of the roll-back function, the automatic window closing feature may be disabled.

Closing the window without the roll-back function

- Try to close the window again within a few seconds by holding the button. **The roll-back function will be deactivated for a small section of the path of the closing window.**
- If the closing procedure takes longer than a few seconds, the roll-back function enabled again. The window stops in case of difficulty to move on and opens again automatically.
- Please refer to a Volkswagen Dealership or qualified workshop if the window still cannot be closed.

WARNING

Closing the electric windows without the roll-back function can lead to severe injuries.

- Always pay attention when closing electric windows.
- Ensure that nobody obstructs the path of the electric windows, especially if the roll-back function is not active.
- The roll-back function does not prevent fingers or other body parts from being pressed against the window frame, resulting in injuries.

 The roll-back function is also activated if the windows are closed using the remote control or mechanical vehicle keys for convenience closing → page 71.

Troubleshooting

Restoring the one-touch opening and closing function

When the battery is disconnected or low with the windows not completely shut or, after some roll back operations, the One touch function will be disabled and needs to be reenabled:

- Switch on the ignition.
- Shut all windows and doors.
- Pull the respective window button upwards and keep it there for a few seconds.
- Release the button, then pull it up again and hold it in this position (till when, please?). The One -touch function is up and running again for use.

It is possible to reenable the One-touch function for the windows individually or for several of them simultaneously.

Steering wheel



Adjusting the steering wheel position

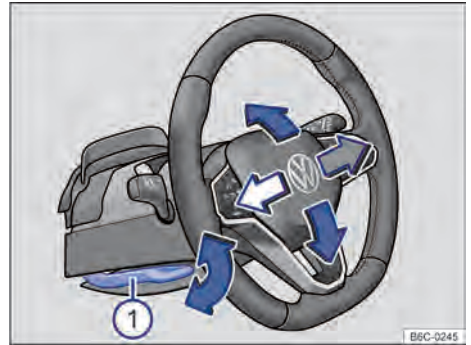

Fig. 63 Below and to the left of the steering wheel next to the steering column trim: steering wheel position adjustment lever.

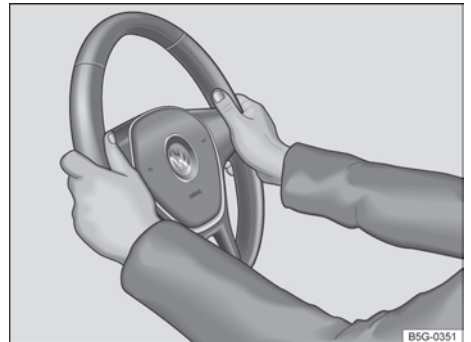



Fig. 64 On the steering wheel: 9 o'clock and 3 o'clock positions.

According to the version of the vehicle, the adjustable steering column may not be available.

Adjust the steering wheel position **before** driving and only while the vehicle is stationary → .

- Push the lever down, holding it by the handle → Fig. 63 ①.
- Adjust the proper distance between the driver and the steering wheel → page 33 using the driver seat controls → page 75. 

- Adjust the steering wheel position in order to be able to hold it by its outer rim *in 9 o'clock and 3 o'clock positions* → Fig. 64 with both hands and slightly flexed arms.
- Firmly hold the lever by the handle and push it upwards until the steering wheel is locked in place → ▲.

⚠ WARNING

- Always firmly push the lever ① upwards by the handle after adjusting, to secure the steering wheel in place.
- Never adjust the steering wheel when the vehicle is in motion. If you require adjusting the steering wheel while driving, safely park the vehicle before adjusting the steering wheel.
- Failure to follow these precautions may compromise the driver's ability to turn the steering wheel while driving.
- To maximize airbag efficiency in case of an accident, the steering wheel must be positioned facing the chest area (and not the face).
- While driving, always keep both hands on the rim of the steering wheel, at the *at the 9 o'clock and 3 o'clock positions* → Fig. 64, to reduce the risk of injury in case the driver front airbag is deployed.
- Never hold the steering wheel in the 12 o'clock position or other positions in which the arms are located over the airbag, since this may result in arm and hand injuries in case the airbag is deployed.
- Failure to observe the above instructions have a direct negative influence on the drivers protection in case of a frontal collision of the vehicle.

Seats and head restraints

Front seat

📖 Introduction

Front seat adjustment options are detailed below. Always ensure the seat is secured in position → page 32.

⚠ WARNING

Always adjust the seat and head restraints before driving.

- Push the front passenger seat as far back as possible.
- Adjust the driver seat in such a way that there is at least 25 cm between your breastbone and the hub of the steering wheel. Adjust the driver seat longitudinally in order for pedals to be fully pressed with slightly bent legs, and ensuring a minimum distance between the driver's knees and the dash panel of 10 cm. If your physical build makes it impossible to fulfil this requirement, contact a Volkswagen Dealership in order to implement any necessary modifications.
- Never travel with the backrest tilted far back. The further back the backrest is tilted, the greater the risk of injury caused by incorrect seat belt routing or an incorrect sitting position.
- Never travel with the backrest tilted forwards. When an airbag is triggered it could force the seat backrest backwards and injure vehicle occupants on the back seats.
- Adopt and maintain the greatest possible distance to the steering wheel and dash panel.
- You should always sit upright with your back against the seat backrest with the front seats properly adjusted. Do not position any body part too close where the airbags are fitted.
- The risk of serious injury is increased for passengers on the rear seat if they are not sitting upright because the seat belts are incorrectly positioned.

⚠ WARNING

Incorrect seat adjustment may cause accidents and severe injuries.

- The seats may only be adjusted when the vehicle is stationary, since the seat could otherwise change position unexpectedly while the vehicle is in motion, leading to a loss of vehicle control. Additionally, an incorrect seating position is adopted while adjusting the seat.
- Adjust the height, inclination and longitudinal direction of the driver's seat only when no one is in the seat adjustment area.
- The area for adjustment of the front seats may not be restricted by any items.

Manual front seat adjustment

📖 Please refer to ⚠ at the start of the chapter on page 74.



Fig. 65 On the front seat: controls.

All the possible controls are described below. According to the seat version the quantity of controls may vary.

Adjusting the seat position

Key for → Fig. 65:

- ① Action the lever and adjust the backrest rake to the desired position. Release the lever to secure the seat backrest in place.
- ② *Only the driver seat*, move the lever several times up or down to adjust the seat height.
- ③ Pull the lever to move the front seat front or backward. The front seat must be locked in place after releasing the lever.

Rear seats

📖 Introduction

The adjustment options for the rear seat are described below. Ensure that the seat position is properly adjusted → page 32.

Rear seat bench

The rear seat bench has clamping sleeves that secure the seat in place. The clamping sleeves may be damaged if the seat is disassembled, in which case they must be replaced.

Volkswagen does not recommend disassembling the seat bench or replacing the clamping sleeves without assistance. Contact a Volkswagen Dealership for more information.

⚠ WARNING

Improperly secured rear seat benches may cause severe injuries.

- Ensure the seat belt is not caught or damaged in the rear seat bench.
- No passengers of any age must be transported in the rear seat bench if it is not secured in place.

⚠ WARNING

An incorrect rear seat adjustment may cause accidents and severe injuries.

- Adjust the rear seat only with the vehicle at standstill, as to the contrary, the rear seat may move unexpectedly while driving. Additionally, an incorrect seating position is adopted while adjusting the seat.

- Adjust the rear seat only when there is no one in the adjustment area of the rear seat.

NOTICE

With the rear seat folded objects may enter the space between the seat and the luggage compartment floor. Prior pushing the rear seat backwards, remove possible objects from the intermediary space.

Folding the rear seat backrest forward or backwards

Please refer to  and  at the start of the chapter on page 75.

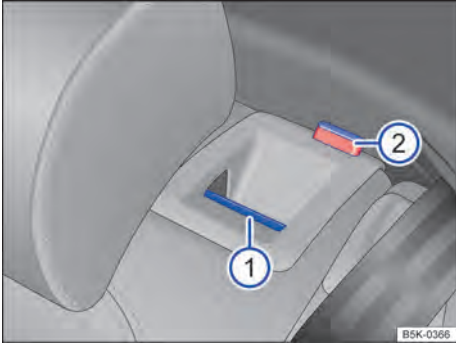





Fig. 66 On the rear seat backrest: unlocking button.

Depending on the vehicle, the rear seat backrest is split. Each rear seat backrest section can be folded forward individually to increase the luggage compartment.

Folding the rear seat backrest forwards

- Push the head rest all the way down → page 77.
- Pull the release button → Fig. 66  forward and simultaneously fold the rear seat backrest forward.
- The respective section of the rear seat backrest will be released when the red marker → Fig. 66  pops up.

Folding the rear seat backrest backwards

- Fold the rear seat backrest backwards and firmly press it until it clicks securely in place → .
- The rear seat backrest must always be securely engaged in order to ensure proper protection of the rear seat belts.
- The red marker → Fig. 66  must no longer be visible.

WARNING

- When folding the rear seat backrest forwards, always ensure that there is no one in the rear seat backrest area.
- Never fold the rear seat backrest forwards or backwards while the vehicle is in motion.
- Ensure that the seat belt is not trapped or damaged when folding back the rear seat backrest.
- Always keep hands, fingers, feet or other body parts away from the seat area when folding the rear seat backrest forwards and backwards.
- The rear seat backrest must always be securely engaged in order to ensure proper protection of the rear seat belts. This applies especially to the centre seat of the rear seat. If a seat is occupied and the respective rear seat backrest has not clicked securely into place, the seat occupant and rear seat backrest may move forward in the event of a sudden braking or driving manoeuvre or during accidents.
- The red marking  indicates that the backrest section is not docked. Always check whether the red marking is visible while the rear seat back rest is in upright position.
- If the rear seat backrest is tilted forward or is not securely locked in place, people or children of any age cannot be transported in such seat.

NOTICE

Folding the rear seat backrest back and forth in an uncontrolled or careless fashion may result in damages to the vehicle and other objects.

- Before folding the rear seat backrest forward, adjust the front seats in order to ensure that the rear seat upholstery or head restraint do not come into contact with the front seats. ►

- Always prior folding the rear seat backrest forward, ensure that there are no objects in the rear seat backrest area.

NOTICE

- On the centre rear seatbelt there is a latch plate height adjuster. When folding the rear seat backrest, the latch plate height adjuster and the latch plate may eventually slip underneath the seat. Should this happen, slide them back to a ready for use position.
- Keep the height adjuster always in a position favouring the handling of the latch plate and such that prevents it from making noise while driving.

Head restraints

Introduction

Depending on the vehicle version, the rear seat headrests are integrated to the seat backrests and are not adjustable.

The headrest adjustment and extension possibilities are described below. Ensure correct posture is adjusted → page 32.

All seats are equipped with head rests. The centre rear head restraint is designed solely for use with the centre rear seat. For this reason do not install the head restraint in other positions.

Correct head rest setting

Adjust the head rest so that its top edge is at the same height as the top of the head – but not lower than eye level. Position the back of your head as close to the head restraint as possible.

Head restraint setting for shorter people

Push the head restraint all the way down, even if the head is then located underneath the top edge of the head rest. There may be a small gap between the head rest and backrest in the lowest position.

Head restraint setting for taller people

Push the head restraint up as far as possible.

WARNING

Driving without head restraints or with incorrectly adjusted head restraints increases the risk of severe or fatal injuries in the event of an accident or sudden driving or braking manoeuvre.

- If a seat is occupied, the head restraint for that seat must be fitted and adjusted properly.
- Each vehicle occupant must adjust the head restraint to suit their body size, to help reduce the risk of neck injuries in case of accidents. At the same time, the top edge of the head restraint must be level with the top of the head, but no lower than eye level. Position the back of your head as close to the head restraint as possible.
- Never adjust the head restraint when the vehicle is in motion.

NOTICE

When removing or fitting head restraints, make sure that they do not hit the roof or front seat backrest. Otherwise, the roof and other vehicle parts could otherwise be damaged.

Adjusting, uninstalling and installing the headrest

Please refer to  and  at the start of the chapter on page 77.

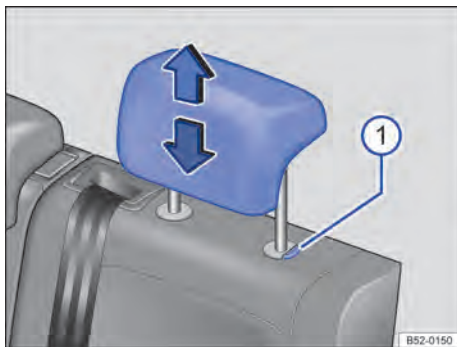

Fig. 67 Rear seat head restraints: adjust.

Depending on the vehicle version, the seat headrests may vary from model to model.

Adjusting the head rest height

- Move the headrest up or down in the direction of the arrow with the button → Fig. 67 ① held down → ▲ in *Introduction* on page 77.
- The head restraint must click securely into position.

Removing the rear head rest

- If needed, adjust the seat backrest so that the head restraint may be removed.
- Push the head rest all the way up → ▲ in *Introduction* on page 77.
- Press and hold → Fig. 67 ① to remove the head rest.

Fitting the rear head rest

- Release the rear seat backrest and fold it a bit forward → page 75.
- Position the head rest correctly over the head rest guides and then insert into the guides of the corresponding seat backrest.
- Press and hold → Fig. 67 ① to push the head rest downwards.
- Push back the rear seat backrest and allow to engage securely.
- Adjust the head rest so that a correct sitting position can be assumed → page 77. <

Front centre arm rest

To *raise*, pull the centre armrest gradually upward in the direction indicated by the arrow → Fig. 68.

To *lower*, pull the centre armrest downward.

⚠ WARNING

The front centre armrest may restrict the driver's liberty of arm movement and lead to severe accidents and injuries.

- Always keep the centre armrest stowage area closed while driving.
- Never ever transport a person or a child of any age on the centre armrest. Needless to say that it is forbidden to do so. <

Seat functions

Centre arm rest

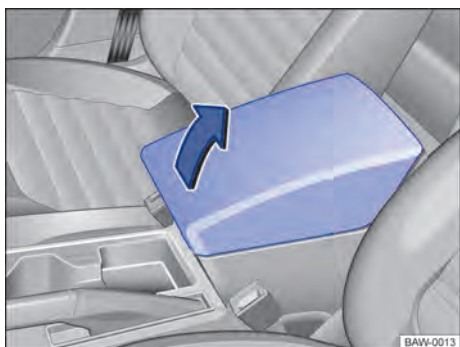

Fig. 68 Front centre arm rest.

Lights

Turn signals

Turn signals on /off

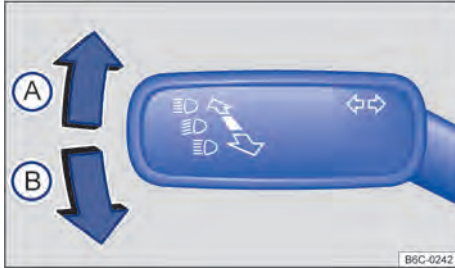

Fig. 69 On the left on the steering column: turn signal and main beam lever.

- Switch on the ignition.
- Move the turn signal and main beam lever from the centre position to the following position:

- (A) Right turn signal ➔.
- (B) Left turn signal ➜.

- Place the turn signal and main beam lever into its basic position to switch the turn indicators off.

If the sound signal does not sound with the turn indicator turned on, visit your Volkswagen dealership or specialized workshop to have the vehicle checked.

Intermittent convenience signals

To enable the convenience turn signal, move the turn signal and main beam lever up or down just to the point of resistance and release it. The turn signals flash three times.

To interrupt the convenience turn signal before time out, move the lever immediately in the contrary direction until the point of resistance and release it.

Depending on the vehicle and radio version, convenience turn signals can be enabled or disabled in the radio system with the button **CAR** OR with the settings button and touch the function surface **CAR** → page 28.

WARNING

Misuse or lack of use of turn signals, as well as forgetting to switch them on when appropriate, may confuse other road users. This could lead to accidents and severe injuries.

- Changing lanes, overtaking and conversion manoeuvres must always be indicated appropriately by using the turn signals.
- Turn off turn signals after changing lanes or completing overtaking and conversion manoeuvres.

The hazard warning lights also work when the ignition is switched off → page 58, *In an emergency*.

If one turn signal fails on the vehicle or on the trailer, the indicator lamp will start flashing approximately twice as fast.

Driving lights

Lights, switching on and off



Fig. 70 Next to the steering wheel: light switch (one variant).

Observe any country-specific regulations when using vehicle lighting.

Depending on the vehicle version, the **AUTO** function may not be available.

Turning the lights on

- Switch on the ignition.
- Turn the light switch to the corresponding position:

AUTO Automatic activation of the driving lights: the driving lights are automatically turned on and off according to the brightness and weather condition → , → page 80.

 Side lights switched on. The icon on the light switch shines in green colour.

 Dipped beam headlights switched off.

Turning the lights off

- Switch off the ignition.
- Turn the light switch to the corresponding position:

0 The lights are off.

AUTO The “Leaving home” function (orientation lighting) may be on → page 80.

 Side lights switched on. The icon on the light switch shines in green colour.

 Dipped beam off - while the vehicle key is inserted in the ignition or, on vehicles with Keyless Access the driver door is closed, the side lights stay on.

Daytime Running Light - DRL (Daytime Running Light)

The daytime running lights, according to the vehicle configuration, may increase the visibility of your vehicle in urban traffic during daytime.

The daytime running light turns on every time the ignition is turned on, when the light switch is switched to **0**,  or **AUTO** (with brightness detection).

The daytime running lights cannot be manually switched on or off.

WARNING

Severe injuries and accidents may occur if the road is not adequately illuminated and if the vehicle or pedestrians are not visible.

- Assist lighting systems are merely ancillary. The driver is responsible for controlling proper vehicle lighting.
- Always switch dipped beam headlights on with low light, fog or poor visibility.

WARNING

The side lights are not powerful enough to illuminate the street and make your vehicle seen by other road users.

- Always switch dipped beam headlights on with low light, fog or poor visibility.

- The rear lights are not connected to the daytime running lights. A vehicle without rear lights on may not be seen by other drivers in darkness, during rainstorms or other poor visibility conditions.

WARNING

The automatic driving light control (**AUTO**) only switches the dipped beam on or off in case of lighting variations.

- Turn the dipped beam on manually in case of special weather conditions, such as fog. 

Functions of the lights

Side light

When the light switch is turned to position , both headlights with the side lights, parts of the tail lights, the registration plate light, the button lights on the centre console and on the instrument cluster turn on.

Automatic driving light control **AUTO**

*Depending on the vehicle version, the automatic driving light control (**AUTO**) may not be available.*

The automatic driving light control is simply an ancillary system, which may not sufficiently recognize all driving conditions.

While the automatic driving light control is activated, low beams and lamps are automatically switched if the twilight sensor detects low lighting on the exterior environment, such as when crossing a tunnel during the day, or during night time. Whenever the vehicle is in an environment with intense solar lighting, with the light switch in position **AUTO**, low beams and lamps will be automatically switched off by the electric central system. And the daytime running lights will turn on.

The twilight sensor is located next to the rain sensor → page 87.

Acoustic warnings if lights are not switched off

When the vehicle key is removed from the ignition and the driver door is opened, acoustic warnings will be emitted under the following circumstances:

- light switch in position  or . 

With the “Coming Home” function turned on, when the driver door is opened, no acoustic alarm is sounded to indicate that the lights are still on.

Main beam on/off

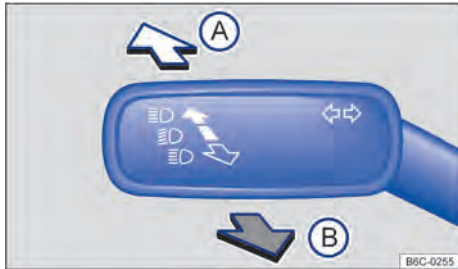

Fig. 71 Left on the steering column: turn signal and high beam lever (variant 1).

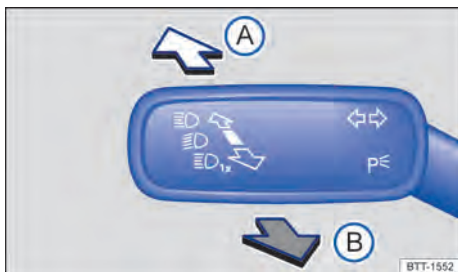

Fig. 72 Left on the steering column: turn signal and high beam lever (variant 2).

Depending on the vehicle version, the turn signal and high beam lever may change.

– Turn ignition and dipped beam on.

Move the turn signal and high beam lever from the central position to the following position (variant 1) → Fig. 71:

- Ⓐ Main beam turned on.
- Ⓑ Turn on the headlight flasher. The *headlight flasher* remains lit for as long as the lever is pulled. The high beam is deactivated when changing the lever position Ⓐ to the centre position.

Move the turn signal and high beam lever from the central position to the following position (variant 2) → Fig. 72:

- Ⓐ Main beam turned on.
- Ⓑ Operate the headlight flasher or turn the main beam off.

With the main beams on or when flashing the headlights the blue indicator lamp lights up on the dash panel insert.

WARNING

Setting headlights too high, and the incorrect use of the main beam, could distract and dazzle other road users. This could lead to accidents and severe injuries.

- Always ensure that the headlights are adjusted correctly.
- Never use the main beam or the headlight flasher if other road users could be dazzled.

Automatic high beam function

Depending on the vehicle version, the automatic high beam function may not be available.

The automatic high beam function automatically prevents glare when vehicles coming in the opposite direction or driving ahead are identified. In addition, the automatic high beam function recognizes generally illuminated areas and deactivates the high beam when passing through villages, for example.

Within the limits of the system, the high beam switches on and off automatically, depending on ambient and traffic conditions, as well as driving speed.

Switching on the automatic high beam function

- ① Switch on the ignition.
- ② Turn on automatic light control **AUTO**.
- ③ By tapping, move the turn signal and high beam lever forward from the base position.

With the automatic high beam function on, the control light comes on on the instrument cluster display. If the automatic high beam function is active, the blue control light of the high beam lights up in the combined instrument panel.

Turn off the automatic high beam function

Turn off the automatic high beam function **AUTO**.

Or: if the automatic high beam function is switched on and active, pull back the turn signal and high beam lever.

Or: if the automatic high beam function is switched on and active, touch the turn signal and high beam lever forwards. The manual high beam is now on. To switch off the manual high beam, if applicable, pull the turn signal and high beam lever backwards.

Or: turn off the ignition.

System limitations

The main beam must be manually turned off in the following conditions, since it is not turned off by the dynamic main beam adjustment:

- In poorly lit areas with high reflection.
- In poor road lighting conditions, such as pedestrian and cyclist lighting.
- In hairpin curves with semi-covered two-way road, steep uphill or downhill areas.
- With incoming vehicles in the opposite direction in roads with centre guards, whenever the driver's field of vision can clearly be obstructed by the centre guard (e.g. truck driver).
- In fog, snow or heavy rainfall.
- In dust and sand storms.
- In case of windscreen damages in the camera line-of-sight area.
- If the camera's line of sight is blurry, dirty or covered by stickers, ice and snow.
- If the camera automatically turns off due to high ambient temperature or long periods of direct sunlight. If the camera is available again, the high beam adjustment will also be available again.
- In case of malfunctioning cameras or power shortage.

WARNING

The increased level of comfort provided by high beam adjustment cannot replace the driver's attention. Improperly connecting the high beams can cause accidents and serious injuries, as the high beams can be distracting and dazzle other road users.

- Always check the driving light yourself and adjust it to light, visibility and traffic conditions.
- The dynamic main beam adjustment system may not correctly identify all driving conditions and only operate in certain situations with restrictions.
- If the camera's viewing area is dirty, covered or damaged, the operation of the high beam adjustment may be affected. This also applies to changes to the vehicle's lighting system, for example due to the installation of an additional headlight.

NOTICE

In order not to influence the operating capacity of the system, the following points must be observed:

- Clean the camera's viewing area regularly and keep it clean.
- Do not cover the camera's viewing area.
- Regularly check the windshield in the camera's view area for damage.

Dynamic main beam adjustment

Depending on the vehicle version, dynamic main beam adjustment may not be available.



The dynamic adjustment of the high beams illuminates the track and its boundaries as much as possible. At the same time, glare from the vehicle ahead or traffic in the opposite direction is avoided. With a camera, the system recognizes other road users who have their own lighting, as well as their distance from the vehicle itself, and specifically turns off areas in the light distribution. When glare from another road user can no longer be avoided, the main beam is switched off completely. In addition, the dynamic main beam control generally recognizes illuminated regions and deactivates the main beam when driving, for example through villages.

Within the limits of the system, the high beam switches on and off automatically, depending on ambient and traffic conditions, as well as driving speed.

Dynamic main beam control can be activated and deactivated in the vehicle settings in the Infotainment system.

Turn on dynamic main beam adjustment

- 1 Switch on the ignition.
- 2 Turn on automatic light control **AUTO**.
- 3 By tapping, move the turn signal and high beam lever forward from the base position.

If the high beams are switched on, the control light comes on  on the instrument cluster display. If the high beam adjustment is active, the blue control light  of the high beam lights up in the combined instrument panel.

Turn off dynamic main beam adjustment

Turn off automatic light control **AUTO**.

Or: if the high beam adjustment is on and active, pull back the turn signal and high beam lever.

Or: if the high beam adjustment is on and active, touch the turn signal and high beam lever forwards.

The manual high beam is now on. To switch off the manual high beam, if applicable, pull the turn signal and high beam lever backwards.

Or: turn off the ignition.

System limitations

The main beam must be manually turned off in the following conditions, since it is not turned off by the dynamic main beam adjustment:

- In poorly lit areas with high reflection.
- In poor road lighting conditions, such as pedestrian and cyclist lighting.
- In hairpin curves with semi-covered two-way road, steep uphill or downhill areas.
- With incoming vehicles in the opposite direction in roads with centre guards, whenever the driver's field of vision can clearly be obstructed by the centre guard (e.g. truck driver).
- In fog, snow or heavy rainfall.
- In dust and sand storms.
- In case of windscreen damages in the camera line-of-sight area.
- If the camera's line of sight is blurry, dirty or covered by stickers, ice and snow.

- If the camera automatically turns off due to high ambient temperature or long periods of direct sunlight. If the camera is available again, the high beam adjustment will also be available again.
- In case of malfunctioning cameras or power shortage.

WARNING

The increased level of comfort provided by high beam adjustment cannot replace the driver's attention. Improperly connecting the high beams can cause accidents and serious injuries, as the high beams can be distracting and dazzle other road users.

- Always check the driving light yourself and adjust it to light, visibility and traffic conditions.
- The dynamic main beam adjustment system may not correctly identify all driving conditions and only operate in certain situations with restrictions.
- If the camera's viewing area is dirty, covered or damaged, the operation of the high beam adjustment may be affected. This also applies to changes to the vehicle's lighting system, for example due to the installation of an additional headlight.

NOTICE

In order not to influence the operating capacity of the system, the following points must be observed:

- Clean the camera's viewing area regularly and keep it clean.
- Do not cover the camera's viewing area.
- Regularly check the windshield in the camera's view area for damage.

"Coming Home" and "Leaving Home" functions (orientation lighting)

With the orientation lighting, the area next to the vehicle is illuminated when leaving ("Coming Home") and when arriving at the vehicle ("Leaving Home"). For vehicles with light and rain sensors, the "Leaving Home" function is automatically controlled.

By activating the “Coming Home” or “Leaving Home” function, the dipped beam headlight and side lights are lit up as orientation lighting.

Depending on the vehicle and radio versions, the switch-off delay, enabling and disabling the function, may be configured in the radio system through the button **CAR** in the **Vehicle settings** menu and enabling or disabling the function **OR** by touching the selection button **⊕**, by touching the function surface **Car** on the **Light settings** → page 28 menu:

Turning the “Coming Home” function on

- Switch off the ignition.
- Action the headlight flasher for about one second.

The “Coming Home” lighting is turned on upon opening of the driver door. The *switch off delay time* starts with the closing of the last vehicle door or of the boot lid.

Turning the “Coming Home” function off:

- Automatically after the set lighting delay time has run out.
- **OR:** automatically when after about 30 seconds after having been turned on, a door or the boot lid of the vehicle remains open.
- **OR:** rotate the light switch to position **0**.
- **OR:** turning the ignition on.

Turning the “Leaving Home” function on:

- Unlock the vehicle when the light switch is positioned to **AUTO** and the rain and light sensor detects *darkness*.

Turning the “Leaving Home” function off

- Automatically after the set lighting delay time has run out.
- **OR:** locking the vehicle.
- **OR:** rotate the light switch to position **0**.
- **OR:** turning the ignition on.

Head light range control



Fig. 73 Next to the steering wheel: control of the headlight range ①.

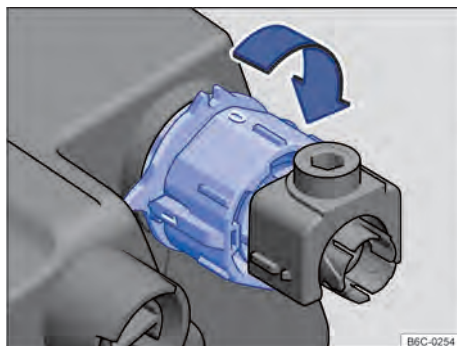

Fig. 74 In the engine compartment: headlight range adjustment switch.

Depending on the vehicle version, headlight range adjustment may not be available or may vary.

With the headlight range control, the low beam light can be adjusted based on vehicle occupation and luggage compartment load conditions. Thereby the driver has the best possible visibility conditions without dazzling the opposite drivers.

Headlight range adjustment with a switch next to the steering wheel:

The headlight range can be adjusted with the → Fig. 73 switch.

- Occupied front seats and empty luggage compartment.
- 1** All seats occupied and empty luggage compartment.
- 2** All seats occupied and loaded luggage compartment.
- 3** Only the driver seat occupied and fully loaded luggage compartment. ▶

Headlight range adjustment with switch in engine compartment:

The headlight range can be adjusted with the → Fig. 74 switch. Turn the switch in the direction of (arrow):

- 0 Occupied front seats and empty luggage compartment.
- 1 All seats occupied and empty luggage compartment.
- 2 All seats occupied and loaded luggage compartment. **OR**
Only the driver seat occupied and fully loaded luggage compartment.

WARNING

Heavy objects in the vehicle may affect headlight visibility and distract other road users. This could lead to accidents and severe injuries.

- Always adjust the light beam to current vehicle occupation and luggage compartment load conditions, in order to avoid dazzling other road users.

Masking or switching over headlights

When driving in countries with opposite driving directions, the asymmetric dipped beam headlights may dazzle oncoming traffic. Therefore, the headlights must be masked or switched over when driving in such countries.

If applicable, mask certain areas of the headlight with thin layers or switch over the position in a specialized company. Additional information can be obtained from your Volkswagen Dealership or qualified workshop.

 The use of thin layers over the headlights is only allowed for short periods of time. Seek out a Volkswagen Dealership for a permanent switch over.

Troubleshooting

Turn signals

-  Left or right turn signals. The indicator lamp flashes twice as fast from normal when one of the vehicle's turn lights has burned out. Check vehicle lighting.



Driving lighting



Driving lights completely or partially out. Check the vehicle lights and replace the respective bulb when burned out → page 197. When all bulbs are in good order, call on a specialized workshop. 



Interior lighting

Instruments and switches lighting

Depending on the vehicle and radio version, switch and instrument lighting brightness can be adjusted in the radio system with the button  **OR** with the settings button  and by touching the function surface  → page 28.

The adjusted brightness is automatically adjusted according to the ambient brightness in the vehicle.

 When the light switch is turned to **AUTO**, a sensor automatically switches the dipped beams, as well as the instrument and switch lighting on and off according to the ambient brightness.

 With the light switched off and the ignition on, the instruments lighting (needles and dials) is turned on. With the decrease of the ambient brightness the lighting of the dials is automatically reduced and, if necessary, turned off completely. This function should remind the driver to turn on the dipped beams, for example, when driving through tunnels. 

Interior and reading lights

Depending on the vehicle version, some interior lighting functions may not be available.

Press the respective button:





 Turning the front interior lighting on and off.



Turn on the automatic lighting of the interior lights when unlocking the vehicle, opening a door or removing the vehicle key from the ignition cylinder. 

0 or OFF  Switch off the automatic lighting of the interior lights when unlocking the vehicle, opening a door or removing the vehicle key from the ignition cylinder.

 /  Switches the respective reading light on or off.

Glove and luggage compartment lights

According to the vehicle version, the glove compartment light and the luggage compartment light may not be available.

Upon opening and closing the glove compartment or the boot lid, a light automatically turns on or off.

 The interior and reading lights are switched off after locking the vehicle or a few minutes after the key is removed from the ignition. This prevents the battery from discharging.

 When airbags are triggered during an accident, interior lights may be automatically activated → page 45, *In case of airbag triggering - Crash detection function.*

Visibility

Window wipers and washers

Window wiper lever

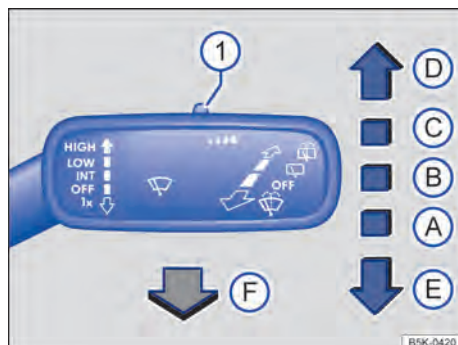

Fig. 75 To the right of the steering column: control the windscreen wipers/washers.

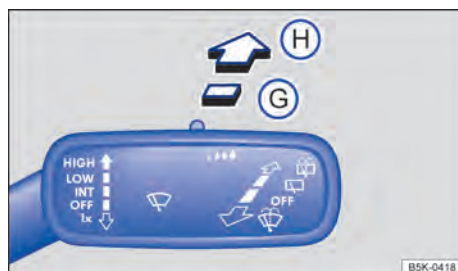

Fig. 76 To the right of the steering column: control the rear window wiper/washer.

Wipers only work with the ignition turned on, while washers also work when the ignition is off.

move the windscreen wipers lever to the desired position → ①:

- ① **OFF** Windscreen / rear window wipers switched off.
- ② **INT** Interval wipe of the windscreen wipers or operation of the rain and brightness sensor. The windscreen wiper interval wipe operates according to the vehicle's speed. The faster the vehicle, the more frequent will be the wiping of the wipers.
- ③ **LOW** Slow wipe.
- ④ **HIGH** Fast wipe.
- ⑤ **1x** touch wipe – brief cleaning.

- F The windscreen washer system is active while the lever is pulled.
- I Adjust the rain sensor sensitivity, if equipped.
- G Rear window wiper system on. The rear window wiper performs a swipe at approximately every 6 seconds.
- H The rear window washer system is active while the lever is pressed.

WARNING

At low winter temperatures, the water of the windscreen washer system without sufficient antifreeze can freeze on the windscreen and limit front visibility.

- At winter temperatures, only use windscreen washing water with sufficient antifreeze.
- Never use the windscreen washer system at winter temperatures before the windscreen has been heated with the ventilation system. The antifreeze mixture may otherwise freeze on the windscreen and restrict vision.

WARNING

Worn or dirty window wiper blades reduce visibility and increase the risk of accidents and severe injuries.

- Windscreen wiper blades should therefore always be changed when they are damaged or worn.

NOTICE

If the ignition is switched off while the windscreen wipers are switched on, the windscreen wipers will resume operation from the same position after the ignition is switched back on; however, in this condition (ignition switched off while windscreen wipers were switched on), the windscreen wipers return to the default position. Ice, snow, and other obstacles on the window can damage the windscreen wipers and the windscreen wiper motor.

- Remove snow and ice from the windscreen wipers before driving.
- Carefully release the frozen window wipers from the window. Volkswagen recommends using an antifreeze spray for such activity.

NOTICE

Do not switch the windscreen wipers on when the window is dry. Dry wiping can damage the window glass.

NOTICE

In icy conditions, always check if the windscreen wiper blades are not frozen to the glass before using the windscreen wipers!

Function of the window wipers

Automatic rear window wiper operation

The rear window wiper turns on automatically when the windscreen wipers are on and reverse gear is engaged. *Depending on the vehicle and radio version*, automatic reverse gear engagement can be enabled or disabled on the radio system with the button OR with the settings button and by touching the function surface → page 28.

Rain and brightness sensor

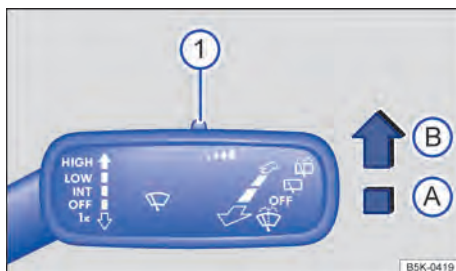

Fig. 77 To the right of the steering column: window wipers lever.

Depending on the vehicle version, the rain and brightness sensor may not be available.

The activated rain and brightness sensor automatically controls the window wiper intervals according to rain intensity.

Enabling and disabling the rain and brightness sensor

Press the lever into the required position

→ Fig. 77:

- Position **(A)** - rain sensor disabled.
- Position **(B)** - rain sensor enabled, automatic wiping if necessary.

Depending on the vehicle and radio version, automatic wipers can be enabled or disabled on the radio system with the button **(CAR)** OR with the settings button **(S)** and by touching the function surface **(Car)** → page 28.

When the automatic wiping is disabled in the radio system, the interval time is adjusted at fixed levels.

Adjusting the rain sensor sensitivity

Depending on the vehicle version, the rain sensor sensitivity setting may not be available.

The sensitivity of the rain sensor can be adjusted manually with the switch on the wiper lever

→ Fig. 77 **(1)** → **(A)**.

- Turn the switch to the right – high sensitivity.
- Turn the switch to the left – low sensitivity.

! WARNING

The rain and brightness sensor may not sufficiently detect rain and fail to activate the window wipers.

- If necessary, manually activate window wipers whenever the rain affects visibility.

Troubleshooting

Altered behaviour of the rain and brightness sensor activation

The possible causes for damages and misinterpretations in the *sensitivity surface area* of the rain sensor are among others the following:

- **Damaged windscreen wiper blades:** a water film or wiping stripes due to damaged wiper blades may extend the activation period, reduce wiping intervals, or result in quick continuous wiping.
- **Insects:** the presence of insects may activate automatic wiping.

- **Salt streaks:** during winter time, salt streaks on the window may cause extremely long wiping patterns until the window is nearly dry.
- **Dirt:** dry dust, wax, glass lining (lotus effect), and detergent residues (car wash) may reduce the rain sensor's sensitivity, eventually reducing its speed or effectiveness. Regularly clean the rain sensor's sensitive surface → page 255 and regularly check the window wiper blades for damages.
- **Crack in the windscreen:** the impact of a rock will activate a wiping cycle when the rain sensor is enabled. After that, the sensor detects the reduced sensitivity surface and adjusts. According to the rock's impact area, rain sensor activation behaviour may be affected.
- **Stickers and labels:** the sensor region must not be externally or internally covered; otherwise, the automatic lighting functions and rain sensor will not operate properly.

A glass-cleaning product, such as alcohol, is recommended to remove wax and polishing residues from the windows.

i Wipers will attempt to remove any obstacles on the windscreen. If the obstacle continues to block the windscreen wipers movement the wipers will stop. Remove the obstacle and reactivate the wipers.

Mirrors

! Introduction

In order to ensure safety, the driver must properly adjust exterior and interior mirrors before driving → **(A)**.

Drivers are able to notice traffic movements behind them and adjust driving behaviours accordingly using the exterior and interior mirrors. There are some areas to the side and behind the vehicle that cannot be seen through the exterior and interior mirrors. Such areas are called blind spots. There may be other vehicles, pedestrians and objects in blind spots.

⚠ WARNING

Adjusting exterior and interior mirrors while driving may distract the driver. This could lead to accidents and severe injuries.

- Only adjust exterior and interior mirrors while the vehicle is stationary.
- When parking, changing lanes and during overtaking or conversion manoeuvres, always observe the vehicle's surroundings, since other vehicles or objects may be located in blind spots.
- Always ensure that the mirrors are properly adjusted and that rear visibility is not limited by misting or other objects.

⚠ WARNING

Inaccurate assessment of the distance of vehicles coming from behind may cause severe accidents and injuries.

- The domed surfaces of exterior mirrors (convex) increase visibility and make objects appear smaller and more distant.
- Using the left and right-hand exterior mirrors to assess the distance of vehicles coming from behind when changing lanes is inaccurate and may cause severe accidents and injuries.
- Whenever possible, use the internal mirror to ascertain the distance of vehicles coming from behind or the distance to other objects.
- Ensure that rear visibility is always unobstructed.

⚠ WARNING

The interior mirror with automatic anti-dazzle function contains an electrolytic fluid which may leak, should the mirror glass be broken.

- The leaked electrolytic fluid may irritate the skin, eyes and breathing organs, especially of people suffering from asthma or similar diseases. Ensure the immediate entry of sufficient fresh air and leave the vehicle or, if this is not possible, open all windows and doors.
- In case of contact of the electrolytic fluid with the eyes or skin, wash immediately with plenty water for at least 15 minutes and seek medical attention.

- In case of contact of the electrolytic fluid with footwear or clothes wash them immediately with plenty water for at least 15 minutes. Carefully clean the affected clothing items prior using them again.
- In case of ingestion of the electrolytic fluid, immediately wash the mouth with plenty water for at least 15 minutes. Do not induce vomiting unless directed to do so by medical personnel. Immediately seek medical assistance.

ⓘ NOTICE

The electrolytic fluid contained in automatic anti-dazzle mirrors may leak due to a broken mirror glass. This fluid damages plastic surfaces. Remove the fluid as quickly as possible, for example, with a damp sponge. ◀

Interior mirror

📖 Please refer to ⚠ and ⓘ at the start of the chapter on page 89.

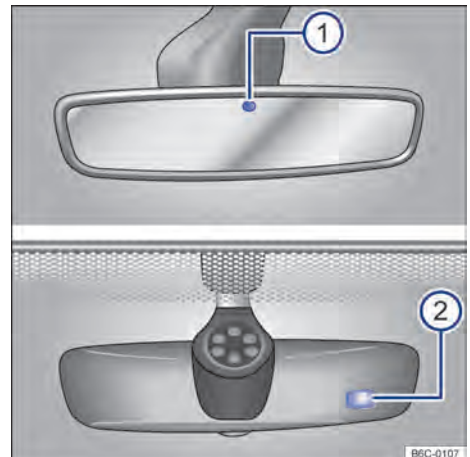

Fig. 78 On the windscreen: automatic anti-dazzle interior mirror. ▶

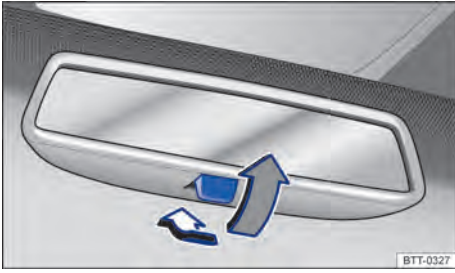

Fig. 79 On the windscreen: manual anti-dazzle interior mirror.

The driver must adjust the interior mirror so that he/she can see clearly through the rear window.

Rear visibility may be hindered or eliminated by objects placed over the luggage compartment cover, for example.

Automatic anti-dazzle interior mirror

With the ignition switched on, the sensors measure the incidence of light from behind → Fig. 78 ① and from the front ②.

Depending on the measured values, the interior mirror is *automatically* anti-dazzled.

When the light incidence detected by the sensors is compromised or interrupted, the interior mirror with automatic anti-dazzle function may malfunction. Similarly external navigation devices on the windscreen or near the automatic anti-dazzle interior mirror may negatively affect the sensors → ⚠.

In some situations the automatic anti-dazzle is disabled, for instance, when reverse gear is engaged.

Manual anti-dazzle interior mirror

- Day position: the lower mirror edge lever points towards the windscreen.
- Night position: pull the lever → Fig. 79 (grey arrow), to avoid glare from the headlights of vehicles travelling behind.

⚠ WARNING

The display light from a mobile phone or portable navigation device may compromise the proper operation of the automatic anti-dazzle interior mirror, potentially leading to severe accidents and injuries.

- A malfunctioning automatic anti-dazzle may prevent the use of the interior mirror to correctly determine the distance to the vehicle following behind or the distance to other objects.
- Never hang objects on the automatic anti-dazzle interior mirror, such objects may impair the proper operation and cause the automatic anti-dazzle to malfunction.



Visibility is hindered by using interior mirrors in the night position.

Exterior mirrors



Please refer to ⚠ and ⌚ at the start of the chapter on page 89.

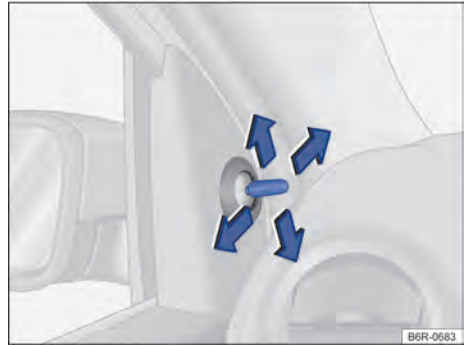

Fig. 80 On the front doors: setting button for the mechanical exterior mirrors.

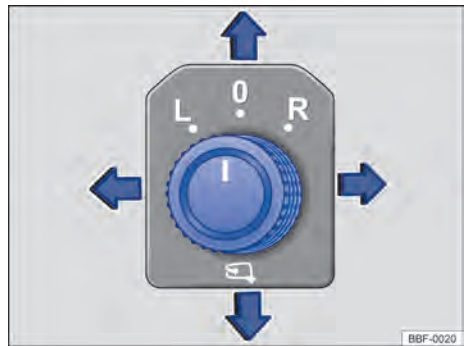

Fig. 81 On the driver door: rotary adjusting knob for the electric exterior mirrors.

Exterior mirrors

- Operate the adjustment knob on the trims of the front doors → Fig. 80.

Electric exterior mirrors

- Switch on the ignition.
- Rotate the rotary knob in the driver door until reaching the desired icon → Fig. 81.
- Move the rotating knob forward, backward, to the right or to the left, as indicated by the arrows, to adjust the exterior mirror.



Electrically folding exterior mirrors inwards (not available in some versions) → ▲.

L
R
O

Adjusting the left exterior mirror.

Adjusting the right exterior mirror.

Neutral position. The exterior mirrors cannot be adjusted and all functions are disabled.

Enabling the exterior mirror functions

Depending on the vehicle and radio version, the following exterior mirror functions must be set one time in the radio system with the button OR with the settings button and by touching the function surface → page 28.

- Enable on the displayed menu the respective function of the exterior mirror.

Folding exterior mirrors inward when parking

If the vehicle is locked or unlocked from the outside, the exterior mirrors will automatically fold in or out. For this the rotary knob must be in position **L**, **R** or **O**.

When the rotary button of the electrically adjustable exterior mirror is in the position, the exterior mirrors stay folded inward.

Saving the right-hand exterior mirror adjustments for reverse gear (tilt down)

- Select a valid vehicle key to which the setting is to be attributed.
- Unlock the vehicle with this vehicle key.
- Switch on the ignition.
- Selecting reverse gear.
- Adjust the right exterior mirror in order to allow proper visibility of kerb edge, for example.
- The set exterior mirror position is automatically saved and attributed to the vehicle key.

Accessing the right-hand exterior mirror adjustments for reverse gear (tilt down)

- Rotate the rotary knob for the exterior mirror to **R**.
- With the ignition turned on, engage the reverse gear. The exterior mirror takes up the saved position.

The saved reverse gear position of the right exterior mirror will be abandoned when driving forward again at a speed greater than about 15 km/h or when the rotary switch is moved from position **R** to another position.

Exterior mirrors can be manually folded (rotated) inwards and outwards. The use position is defined by a clear locking position in both sides (left and right).

WARNING

Exterior mirrors should only be adjusted when the vehicle is stationary, in order to prevent the driver from being distracted.

WARNING

Careless folding of exterior mirrors may cause injuries.

- Make sure there are no obstacles in the operating area when folding exterior mirrors in or out.
- Handle with care in order to prevent fingers from getting stuck between the exterior mirror and the mirror frame, while the mirror is moving.

NOTICE

Always fold in exterior mirrors in automatic washing systems.

- Do not fold electric exterior mirrors in or out, since this could damage the electrical system.

In case of failure, electric exterior mirrors may be manually adjusted by pressing the edge of the mirror surface.

Sliding headliner

Sun visor

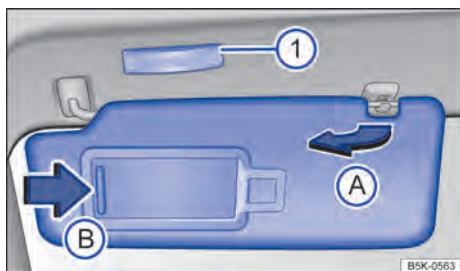

Fig. 82 Sun visor.

Depending on the vehicle version, the sun visor may contain different combinations, containing or not: lighting, mirror cover and vanity mirror.

Various positions for the driver and front passenger sun visors:

- Folding the sun visor down to the windscreen.
- Carefully remove the sun visor from the support, holding the support base, and swivel towards the door → Fig. 82 (A).

Vanity mirrors

A vanity mirror is located behind a cover on the folded down sun visor. When opening the cover → Fig. 82 (B) a lamp lights up (1).

The lamp will go out when the vanity mirror cover is pushed back or the sun visor is folded back up.

⚠ WARNING

Sun visors folded downwards may reduce the field of vision and decrease safety.

- Sun visors and sunblind should always be replaced in their holder if they are not being used.

📌 NOTICE

Handle sun visors and vanity mirror covers carefully in order to avoid damages.

Heating and air conditioning

Heating, ventilating, cooling

📖 Introduction

The following equipment may be installed in the vehicle:

The **ventilation and heating system** heats and ventilates the vehicle interior. The ventilation and heating system does not cool.

The **air-conditioner** or **Climatronic** cool and dehumidify the air. They work best when all windows are closed. In case of accumulated heat in the vehicle interior, ventilation may speed the cooling process.

Indication of active functions

The lighted LEDs on controls and buttons indicate that a function is active.

⚠ WARNING

Poor visibility through all windows increases the risk of collisions and accidents, which can lead to severe injuries.

- Always ensure that all windows are free of ice, snow and mist in order to have good visibility.
- Maximum heat output, which is needed to defrost the windows as quickly as possible, is only available when the engine has reached its operating temperature. Do not start your journey until you have good visibility.
- Always ensure that the heating and fresh air system or air conditioning and rear window heating system are used properly in order to guarantee proper exterior visibility.
- Never use the air recirculation mode for extended periods. If the cooling system is switched off, the windows can mist up very quickly in air recirculation mode and reduce visibility considerably.
- Always switch off the air recirculation mode if it is not required.

⚠ WARNING

Stale air can cause tiredness and lack of concentration in the driver, which in turn can cause collisions, accidents and severe injuries.

- Never leave the blower off for extended periods and never use the recirculation mode for extended periods, since this prevent fresh air from entering the vehicle.

📌 NOTICE

Do not place food, medicines or other temperature sensitive object in front of the vents. Food, medicines or other heat or cold sensitive objects may be damaged or rendered unusable by the air outflow.

📌 NOTICE

- Switch off the air conditioning system if you suspect that it has been damaged. This can help to prevent further damage. The air conditioning system must be checked by a Volkswagen Dealership or qualified workshop.
- Repairs to the air conditioning system require specific knowledge and tools. Volkswagen recommends using a Volkswagen Dealership for this purpose.

Air conditioning controls

📖 Please refer to ⚠ and 📌 at the start of the chapter on page 92.

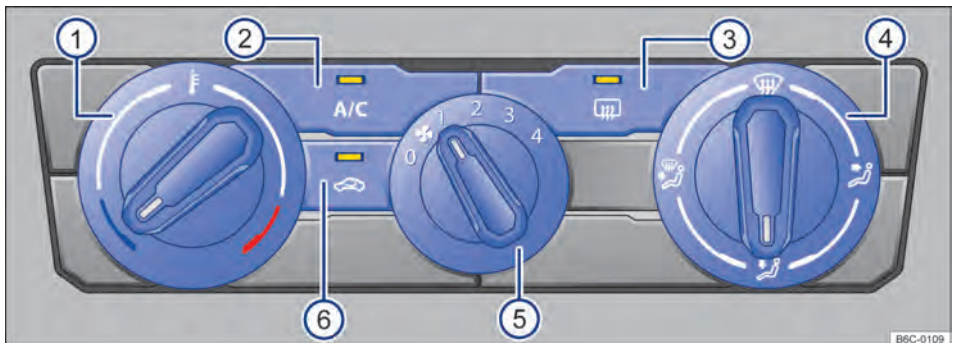

Fig. 83 Air conditioning controls.

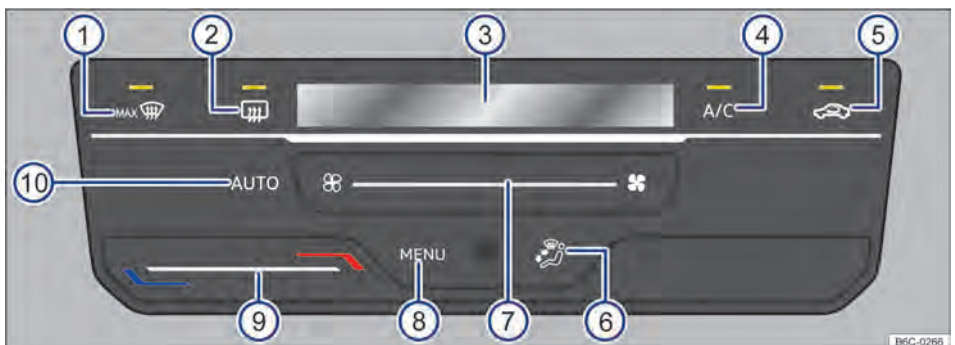



Fig. 84 Climatronic controls.

Some functions and buttons are version dependent and depend on the type of system fitted.

Turning off



- *Air conditioner*: rotate the blower regulator to level 0 → Fig. 83 ⑤.
- *Climatronic*: slide your finger to the left under the function surface → Fig. 84 ⑦, then press the leftmost  button.

AUTO – Automatic mode

When touching the function button  → Fig. 84 ⑩ it is possible to switch on the Climatronic automatic mode.

The automatic mode ensures constant temperatures in the vehicle interior. The air temperature, the air volume and its distribution is automatically regulated. Automatic operation turns off when ventilation is changed manually → Fig. 84 ⑦ or by changing the air distribution across the function button → Fig. 84 ⑥.

A/C – Cooling mode

- *Air Conditioner*: press the button  → Fig. 83 ② to turn the cooling operation on and off.
- *Climatronic*: touch the function button  → Fig. 84 ④ to turn on and off the cooling functioning.

In cooling mode the air is dehumidified.

■ / ■ – Temperature

- *Air-conditioning*: rotate the left rotary regulator → Fig. 83 ①.
- *Climatronic*: slide your finger under the function button → Fig. 84 ⑨.



On the Climatronic display → Fig. 84 ③ the set temperature is displayed.

🌀 – Blower

- *Air-conditioning*: rotate the blower regulator → Fig. 83 ⑤.
- *Climatronic*: slide your finger under the function button → Fig. 84 ⑦.

🌀 – Air recirculation mode

In air recirculation mode, no fresh air enters the interior of the vehicle → page 96.

- *Air Conditioner*: press the  button → Fig. 83 ⑥.
- *Climatronic*: Touch the function button  → Fig. 84 ⑤.

Air distribution

- *Air-conditioning*: rotate the right regulator → Fig. 83 ④ to the desired position.
- *Climatronic*: touch the function button → Fig. 84 ⑥ on the desired position, the selected distribution will be indicated on the display ③.



– Air distribution to the upper body part with the chest vents in the dash panel.



– Distribution of air to the footwell.



– *Climatronic* – Air distribution to the upper body part and the footwell.



– Air distribution to the windscreen and the footwell area.





– *Air conditioning* – Air distribution to the windscreen.



– *Climatronic* – Air distribution to the windscreen.

MAX | – Defrost function

The defrosting function eliminates the frost from the windscreen.





- *Air conditioning*: rotate the right rotary regulator to  → Fig. 83 ④.
- *Climatronic*: Touch the function button  → Fig. 84 ①.

Air-conditioning: under the defrosting function the air circulation mode is disabled and the air conditioner compressor is turned on to remove the humidity from the air. With the defrost function enabled, the air circulation mode cannot be turned on and the air conditioner compressor cannot be turned off.

Climatronic: under the defrost function, the air is dehumidified and the blower is set to a high level. ▶

– Rear window defrost function

To turn the rear window heating on and off with the engine running.

- *Air Conditioner*: press the button  → Fig. 83 .
- *Climatronic*: touch the function button  → Fig. 84 .

The rear window defroster is turned off automatically after about 10 minutes.

Recommended air conditioner settings



- Switch the air recirculation mode off.
- Adjust the blower to level 1 or 2.
- Put the temperature adjuster in the middle position.
- Open and align all the vents of the dashboard.
- Set the air distribution controller to the desired position.
- Press the  button on the panel to switch the cooling system on.

Climatronic recommended settings

- Touch the function button .
- Set the temperature to +22 °C.
- Open and align the dash panel vents.

Fast cooling inside the vehicle

In order to obtain fast cooling inside the vehicle, follow the instructions below:

- Turn the temperature regulator or touch the function button fully to the left.
- Set the air distribution to the position .
- Turn regulator or touch fan function button to maximum level. The air conditioner and air recirculation mode are automatically turned on.
- Case the air conditioner does not turn on, press the  key or touch the function button to switch the cooling system on.
- If the vehicle is exposed to the sun for extended periods, open the front door windows partially or completely for a brief amount of time (1 to 3 minutes), in order to remove the hot air mass inside the vehicle.
- Close the windows and, if necessary, press the  key or touch the function button to turn the air recirculation mode on.

Air conditioning menu in VW Play

For vehicles with VW Play, press **MENU** → Fig. 84  to open the air conditioning menu on the radio.

The air conditioning menu on the VW Play display is only available in Climatronic.

In the air conditioning menu you will find, for example, the temperature adjustment → page 94 and air distribution functions → page 94.

The top part of the screen shows the current air conditioning settings, for example, the automatic mode air conditioning profile.

The bottom part of the screen shows function areas for frequently used air conditioning functions.

Air conditioning operating states



The air conditioning operating states are displayed in colour:

-  Cool down.
-  Warm.

NOTICE

To prevent damages to the rear window defroster, no sticker should be stuck on the inside on the filaments.

 After the window is cleared, the function must be switched off. Lower current consumption also decreases fuel consumption.

 If the air conditioner and air recirculation mode are turned off manually, the system will not automatically turn them on next time the blower is switched off and on again. The system will only start working automatically again after the temperature switch is removed from the full left position and placed back into this position. 

Air recirculation mode



 Please refer to  and  at the start of the chapter on page 92.

The air recirculation mode prevents outside air from entering the vehicle.

- Press the  key or touch the function button on the dash panel to turn the air recirculation mode on or off.

When is the air recirculation mode turned off?

The air recirculation is turned off under the following situations → :

- When the Climatronic  function button is turned on.
- When the air conditioner air distribution regulator or surface button is positioned to position .

WARNING

Stale air can cause tiredness and lack of concentration in the driver, which in turn can cause collisions, accidents and severe injuries.

- Never leave the blower off for extended periods and never use the recirculation mode for extended periods, since this prevent fresh air from entering the vehicle.
- With the cooling system switched off, the windows can mist up very quickly in air recirculation mode, reducing visibility considerably.
- Always shut down the air recirculation mode when no longer necessary.

NOTICE

Do not smoke with the air recirculation mode turned on. The smoke drawn into the cooling system can leave a residue on the evaporator and the dust and pollen filter, producing a permanent unpleasant odour.

 At very high outside temperatures, it is recommended to select the recirculation mode for a short time, to cool down the interior of the vehicle faster.

Troubleshooting

 Please refer to  and  at the start of the chapter on page 92.

The following hints and operational instructions help with the correct use of the system.

The cooling system for the vehicle interior only works when the engine is running and the blower is switched on.

The air conditioning system operates most effectively with the windows closed. However, if the vehicle has heated up after standing in the sun for some time, the air inside can be cooled more quickly by opening the windows for a short time.

Why does the cooling system turn off automatically or cannot be turned on?

- The engine is not running.
- The blower is switched off.
- The air conditioning system fuse has blown.
- Room temperature is below approximately +3 °C.
- The air conditioner compressor has been temporarily deactivated because the engine coolant temperature is too high.
- There is a fault on the vehicle. The air conditioning system must be checked by a Volkswagen Dealership or qualified workshop.

Settings for optimal road visibility

- Keep the air entrance of the windscreen free of ice or leaves to increase the heating or cooling power and prevent the frosting of the windows → page 249.
- Keep the air slot of the rear area of the luggage compartment free so that the air may flow freely from the front to the back through the vehicle.
- When the engine coolant has reached its operational temperature, the highest heating power will have been reached and the fastest window defrosting.

Dust and pollen filter

- ◀ The dust and pollen filter with activated charcoal reduces the level of particles in the outside air entering the vehicle.

The pollen and dust filter needs to be regularly replaced to keep the air conditioner's efficiency unimpaired. Case the vehicle is frequently used in ▶

heavily polluted environments, the filter should be replaced between servicing events
→ page 249.

Water vapour underneath the vehicle

If the outside humidity and temperature are high, **condensed water** may drip off the cooling system's evaporator and form a pool of water underneath the vehicle. This is normal and does not indicate a leak!

 The air conditioning supercharger consumes engine power during cooling, thus contributing to increased fuel consumption. To reduce cooling time to a minimum, observe the following instructions:

- If a vehicle stationary under the sun is too hot, open the doors and windows for a few seconds in order to let the hot air out.
- Ensure that external hot air does not enter the vehicle, for example, through an open window, while the air conditioning is switched on.
- If it is possible to reach the desired temperature without switching the air conditioning on, only use the ventilation system.

 When arriving at destination (about 2 minutes before), turn the air conditioner off leaving only the ventilation operating. This helps reducing the humidity in the evaporator, reducing the appearance of unpleasant odours in the interior of the vehicle.

 The air conditioning compressor may momentarily shut down in some situations, such as stepping on the brakes, accelerating or manoeuvring.

Driving

Driving guidelines

Pedals

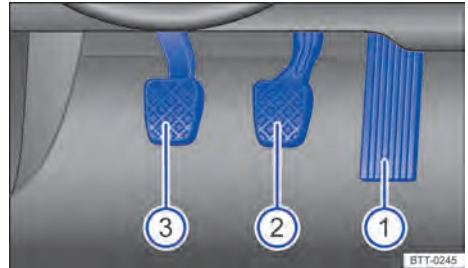

Fig. 85 In the footwell: pedals in vehicles with manual transmission.

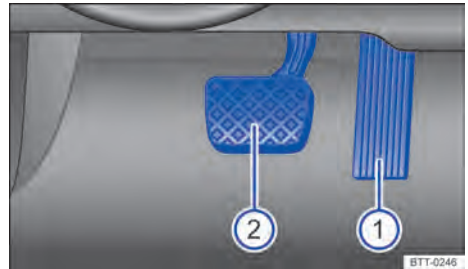

Fig. 86 In the footwell: pedals in vehicles with automatic gearbox.

Key for → Fig. 85 and → Fig. 86:

- ① Gas pedal
- ② Brake pedal
- ③ Clutch pedal, *in vehicles with a manual gearbox.*

The operation and freedom of movement of all pedals must never be impaired by objects or floor mats.

Only use floor mats that leave the pedal area free and can be securely fastened in the footwell.

WARNING

Items in the driver footwell can hinder pedal operation. This can lead to loss of control of the vehicle and increase the risk of serious injury.

- Ensure that all pedals can always be operated without any hindrance.

- Always safely secure foot mats.
- Additional foot mats or other floor coverings should never be placed over the fitted foot mat.
- Ensure that no objects can enter the driver footwell while the vehicle is in motion.

NOTICE

Ensure that you are able to operate the pedals freely at all times. For example, the braking distance to fully stop the vehicle will be longer if a braking circuit is faulty. The brake pedal will have to be depressed further and harder than normal. ◀

Gear change recommendation

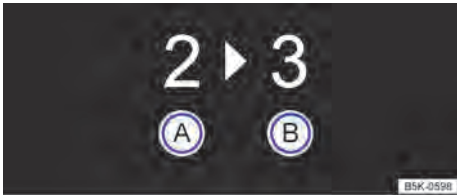

Fig. 87 On the instrument cluster: gear change indicator.

Key for → Fig. 87:

- Ⓐ Current engaged gear.
- Ⓑ Recommended gear shift.

Depending on the vehicle version, a gear shift recommendation may be indicated on the instrument cluster display to optimize fuel savings.

In vehicles with automatic gearbox the selector lever must be in the Tiptronic position → page 112.

When the ideal gear is already selected, no gear shift is recommended. The currently engaged gear is displayed.

CAUTION

The gear-change indicator is merely a supporting system and must not distract the driver from traffic.

- The gearshift indicator merely assists the driver in increasing fuel savings. The driver is exclusively responsible for assessing whether current vehicle, road, and traffic conditions

allow safely following the gearshift indicator (e.g. when overtaking or driving with fully-loaded vehicles).

 Enhanced gear selection decreases fuel consumption.

 Warning texts may vary according to the instrument cluster version.

 In vehicles with manual gearbox the gear-change indicator display turns off when the clutch pedal is actuated or, in vehicles with automatic gearbox, when leaving the Tiptronic gate. ◀

Economical driving style

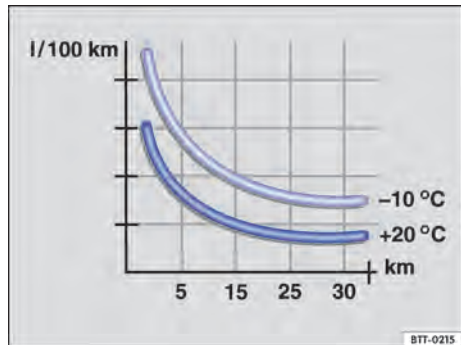

Fig. 88 Fuel consumption in litres per 100 km at two distinct ambient temperatures.

Driving correctly it is possible to reduce fuel consumption, harming the environment and engine, brake and tyre wear. Below are some tips on minimizing the environmental impact and save.

Fuel consumption, environmental impact and wear on the engine, brakes and tyres depend largely on 3 factors:

- Personal driving style.
- Conditions of use (such as weather and road surface characteristics).
- Technical conditions.

By adopting an economical driving style and anticipating the traffic situation ahead, you can easily reduce fuel consumption by 10 to 15%. ▶

A car uses most fuel when accelerating. If you think ahead when driving, you will need to brake less and thus accelerate less. Wherever possible, let the car roll slowly to a stop, for instance when you can see that the next traffic lights are red.

Changing gear earlier

Basically: the highest gear is always the most economical gear. As a rule of thumb, the following applies to most vehicles: at a speed of 30 km/h (19 mph) drive in 3rd gear, at 40 km/h (25 mph) in 4th gear and at 50 km/h (31 mph) in 5th gear.

If traffic and driving scenarios are suitable, “skipping” gears when changing up a gear will also save fuel.

Do not drive gears to their upper limit. Use 1st gear only for pulling away then quickly change up to 2nd gear.

Vehicles with gearshift indicator help reduce fuel consumption by recommending ideal gears for each specific situation.

Rolling to a stop

Taking your foot off the accelerator will interrupt the supply of fuel to the engine and decrease fuel consumption.

Therefore, in situations such as approaching a red traffic light, let the vehicle roll without applying the accelerator. Only press on the clutch pedal to disengage if the vehicle becomes too slow or if the stopping distance is longer. The engine will then run at idling speed.

Switch off the engine in situations in which the vehicle might be stationary for a long time, e.g. at a level crossing.

Thinking ahead when driving, and driving with the “flow” of traffic

Frequently applying the brake and accelerator will increase fuel consumption. By thinking ahead when driving and by maintaining a sufficient distance to the vehicle in front, simply keeping your foot off the accelerator will stop the speed from fluctuating. This means that active braking and accelerating is not always necessary.

Driving smoothly and evenly

Smoothness is even more important than speed. The more evenly you drive, the lower your fuel consumption will be.

When driving on a motorway, it is much more effective to drive at a constant moderate speed than to drive with constant acceleration and braking. As a rule, driving with a constant style will get you to your destination just as quickly.

Using additional equipment in moderation

It is always important to be comfortable in your vehicle, but it is also important to consider the environment.

Some equipment will increase fuel consumption when switched on (examples):

- Air conditioning cooling system: if the air conditioning system is set to a very high or low temperature it will require a lot of energy, which is generated by the engine. Therefore the temperature setting in the vehicle should not vary too much from the outside temperature. It may be a good idea to air the vehicle before setting off and then to travel a short distance with the windows open. The air conditioning system should then be switched on once the windows have been closed.
- Keep the windows closed when driving at high speeds. Open windows increase fuel consumption.
- Switch off the rear window defrost function when the window is clear.

Other factors which increase fuel consumption (examples):

- Fault in engine management system.
- Driving in hilly regions.
- Driving with a trailer.

Avoid short journeys

Directly after a cold start, the engine has a very high fuel consumption. The engine reaches its working temperature after a few kilometres, when fuel consumption will return to a normal level.

The engine and catalytic converter need to reach their proper **working temperature** in order to minimise fuel consumption and pollutant emissions. The **outside temperature** also has a decisive influence.

The → Fig. 88 shows the variation in fuel consumption for the same journey at 20 °C and -10 °C.

Therefore, avoid making too many short journeys and car share whenever possible. ▶

Under the same conditions, the vehicle will use more fuel in the winter than in the summer.

Not only is it illegal in some countries to “warm up” cold engines, it is also technically unnecessary and a waste of fuel.

Adjust tyre pressure

The correct tyre pressure reduces rolling resistance and therefore also fuel consumption.

When purchasing new tyres, always make sure that the tyres have optimum rolling resistance.

Using low friction engine oil

Fully synthetic low-viscosity engine oils, known as low-friction engine oils, reduce fuel consumption. Low viscosity engine oils decrease frictional resistance in the engine and spread better and more quickly, especially for cold starts. They are especially effective in vehicles which make a lot of short journeys.

Always make sure that the engine oil level is correct and that you keep to the service intervals (oil change intervals).

When purchasing engine oil, always make sure it complies with engine oil standards and has been approved by Volkswagen.

Avoid unnecessary loads

The lighter the vehicle, the more economical and environmentally-friendly it is. An extra weight of 100 kg increases fuel consumption, for example, by up to 0.3 l/100km.

Remove all unnecessary items and loads from the vehicle.

Remove any unnecessary special equipment and accessories

The more aerodynamic a vehicle, the lower its fuel consumption. Special equipment and accessories, such as roof carriers or bicycle carriers, make the vehicle less aerodynamic.

You should therefore remove any special equipment and luggage carriers that are not being used, especially if you are going to be driving at high speeds.

WARNING

Adapt your speed and distance from the vehicles ahead to suit visibility, weather, road and traffic conditions.



Information on the brakes

New brake pads cannot generate the full braking effect during the first 300 km and must first be “run in” → . However, you can compensate for the slightly reduced braking force by applying more pressure to the brake pedal. **During the run-in period, the braking distance is longer when the brakes are depressed fully or during emergency braking** than with brakes that have been fully run in. In the run-in period, the brakes should not be depressed fully and situations should be avoided that create a heavy load on the brakes. For example, when driving too close to other vehicles.

The **rate of wear** of the brake pads depends to a great extent on use conditions and driving style. When frequently driving in city traffic and short distances or in sporty manner, the brake pad thicknesses needs to be periodically checked by a Volkswagen dealership or a specialized workshop.

When driving with **wet brakes**, for example after driving through water, after heavy rainfall or after washing the vehicle, the braking effect may be delayed as the brake discs will be wet, or possibly iced up (during the winter). Brakes must be “dried” as soon as possible by carefully braking at higher speed. Ensure that no following vehicle and no other road user is put at risk as a result of this action → .

A layer of salt that accumulates on the discs and pads will delay the braking effect and increase the braking distance. If the brakes on the vehicle have not been applied for a long time on roads that have been gritted with salt, the layer of salt must be reduced through careful braking → .

Corrosion on the brake discs and **dirt** in the brake pads are facilitated through long periods of inactivity, low mileage and low load levels. If there has been little or no use of the brake pads, or if there is corrosion, Volkswagen recommends that the brake discs and brake pads be cleaned by carefully braking several times at higher speed, always in compliance with speed limits and current driving conditions (e.g. wet or dry roads, night or day driving). Ensure that no following vehicle and no other road user is put at risk as a result of this action →  

Brake servo

The brake servo will only function when the engine is running and reinforces the pressure applied by the driver on the brake pedal.

If the brake servo is not functioning or the vehicle is being towed, the brake pedal will have to be depressed more forcefully, since the braking distance will be increased due to the lack of assistance for the brake system → ⚠.

⚠ WARNING

New brake pads will not have the optimal braking effect when first fitted.

- New brake pads cannot generate the full braking effect during the first 300 km and must first be "run in". A reduced braking effect can be increased by applying more pressure to the brake pedal.
- You must drive particularly carefully when driving with new brake pads in order to reduce the risk of accidents, severe injuries and loss of vehicle control.
- Never drive too close to other vehicles when running in new brake pads, and never create a driving situation that will place a heavy load on the brakes.

⚠ WARNING

Overheated brakes reduce the braking effect and considerably increase the braking distance.

- When driving downhill the brakes are placed under particular strain and become hot very quickly.
- Non-standard or damaged front spoilers could restrict the airflow to the brakes and cause them to overheat.

⚠ WARNING

Wet brakes or brakes coated with ice or road salt react more slowly and require longer braking distances.

- Carefully apply the brakes to test them.
- Always dry brakes and clean off any coating of ice and salt with a few cautious applications of the brake when visibility, weather, road and traffic conditions permit.

⚠ WARNING

Driving without the brake servo can considerably increase the braking distance and thus cause accidents and serious injuries.

- Never allow the vehicle to roll if the engine is switched off.
- If the brake servo is not functioning or the vehicle is being towed, the brake pedal will have to be depressed more forcefully, since the braking distance will be increased due to the lack of assistance for the brake system.

ⓘ NOTICE

- Never let the brakes "rub" by applying light pressure to the brake when it is not necessary to brake. Continual pressure on the brake pedal will overheat the brakes. This can considerably reduce the brake effect, increase the braking distance and, in certain circumstances, cause the brake system to fail completely.
- Before driving down a long, steep gradient, reduce speed and change to a lower gear or move the selector lever to a lower gear. This will make use of the engine braking effect and relieve the load on the brakes. The brake system could otherwise overheat and fail. Only use the brakes to slow down or stop the vehicle.

 If the front brake pads are tested, the rear brake pads should be tested at the same time. Visual check of the thickness of all brake pads should be carried out regularly by checking the brake pads through the openings in the wheels or from the underside of the vehicle. If necessary, remove the wheels to carry out a comprehensive check. Volkswagen recommends using a Volkswagen Dealership for this purpose. <

Driving a loaded vehicle

For good vehicle handling when driving a loaded vehicle, please observe the following:

- Stow all items of luggage securely → page 178.
- Accelerate carefully and gently.
- Avoid sudden braking and driving manoeuvres.
- Brake earlier than in normal driving.
- If applicable, observe the information concerning driving with towing mode → page 184. ▶

WARNING

Moving loads can severely impair the vehicle's stability and driving safety, which can cause accidents and severe injuries.

- Secure objects properly to prevent them from sliding.
- Use suitable straps when securing heavy objects.
- Secure the rear seat backrest in an upright position.



Driving with the rear lid open

Driving with the boot lid open is particularly dangerous. Ensure that the open boot lid and any objects are secured properly, and adopt appropriate measures to reduce the quantity of toxic exhaust fumes entering the vehicle.

WARNING

Driving with an unlocked or open boot lid can cause serious injuries.

- Volkswagen recommends not driving with an open boot lid. However, if such scenario is absolutely indispensable, observe the following instructions:
 - Always stow all objects in the luggage compartment securely. Loose objects can fall out of the luggage compartment and injure other road users.
 - Always drive carefully and defensively.
 - Avoid any abrupt or sudden driving and braking manoeuvres as this can cause the open boot lid to move unpredictably.
 - Any objects protruding from the luggage compartment must be marked to ensure that they are visible to other road users. Legal provisions must be followed.
 - In case of objects protruding from the luggage compartment, the boot lid must never be used to “hold” or “fasten” objects.
 - Remove the load mounted over the boot lid whenever it is necessary to drive with the boot lid open.

WARNING

Poisonous exhaust fumes may enter the vehicle interior when the boot lid is open. This could result in loss of consciousness, carbon monoxide poisoning, serious injury and accidents.

- Always drive with the boot lid closed in order to prevent toxic gases from entering the vehicle.
- If exceptional circumstances require you to drive with an open boot lid, you must do the following to reduce the quantity of toxic exhaust fumes that could enter the vehicle:
 - Close all windows.
 - In vehicles with air conditioning, switch off the air recirculation mode.
 - Open all vents in the dash panel.
 - Switch the blowers to the highest setting.

NOTICE

The vehicle level changes when the boot lid is open.



Driving through water on roads

Avoid driving through water on roads. Driving under such conditions hinders the driveability, and may cause severe damages to the vehicle, compromising the safety of the driver and other passengers. If absolutely necessary to cross the flooded area, observe the following in order to prevent damages to the vehicle, driver, and passengers:

- Check the water depth before driving through water on roads. The water level must be **no higher** than the lower edge of the vehicle body (underneath the doors) → .
- Do not drive faster than walking speed.
- Never stop the vehicle, reverse or switch off the engine while in water.
- Oncoming vehicles create waves that can increase the water level for your vehicle to such an extent that it is not safe to drive through the water.
- When crossing flooded areas, vehicles with Start-Stop system disable the system manually → page 108.



WARNING

After driving through water, mud and dirt roads the brakes may be hindered due to the humidity or freezing of brake pads or disks, increasing the braking distance.

- “Dry the brakes and eliminate ice” through careful braking manoeuvres. Proceed without putting other drivers at risk or failing to abide by legal requirements.
- Avoid sudden braking manoeuvres after crossing through water in roads.

NOTICE

- When driving through water in roads, some vehicle components such as the engine, transmission, chassis or electrical system, may be severely damaged.
- Never drive through salt water, since salt can cause corrosion. Rinse all components that have been exposed to salt water immediately with fresh water.

Running-in

A new engine needs to be run in during the first 1,500 kilometres. All the moving parts must be able to adjust themselves to each other. During the first hours of operation the engine has to cope with a higher internal friction than later on.

Up to 1,000 kilometres, the following applies:

- Do not fully depress the accelerator.
- Do not drive the vehicle at more than 2/3 of the top engine speed.
- Do not drive with a trailer attached.

Between 1,000 and 1,500 kilometres

- *Gradually* increase the speed and engine rpm, limited to the respective driving location.

The style of driving during the first 1,500 kilometres will also affect the engine quality. Even after the engine has been run-in, and especially with a cold engine, drive the vehicle at moderate rpm's in order to reduce engine wear and to increase its useful life span.

Do not drive at engine speeds which are too low. Always shift down gear if the engine is not running “smoothly”.

 If the engine is run in gently, the life of the engine will be increased and its oil consumption reduced.

Using the vehicle in other countries and continents

The vehicle is produced specifically for a certain country and complies with this country's registration regulations valid at the time of vehicle production.

If the vehicle is going to be sold in another country or used in another country for an extended period, the legal requirements applicable in that country must be observed.

In some cases, certain equipment will have to be fitted or removed and functions deactivated. The scope and type of service available may also be affected. This is particularly important if the vehicle is driven in another climate region for a long period of time.

Because different frequency bands are used in different countries, the radio unit may not work in other countries.

NOTICE

- Volkswagen may not be held liable for damages caused to the vehicle due to low-quality fuel, inadequate servicing work, and use of non-genuine parts.
- Volkswagen may not be held liable in case the vehicle does not comply or only partially complies with legal requirements from other countries and continents.

Troubleshooting

Brake system malfunction

A brake circuit may have failed if you have to reduce speed and the vehicle does not brake as normal (sudden increase in braking distance). This will be indicated by the warning lamp  and in some cases a text message. Go to a Volkswagen Dealership or qualified workshop as soon as possible. Drive at low speed when doing this and anticipate much longer braking distances and an increase in the pressure required on the pedal.

Starting and stopping the engine

Ignition cylinder

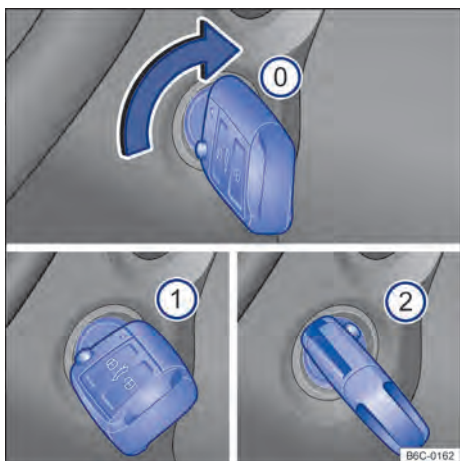



Fig. 89 Next to the steering wheel, to the right: vehicle key positions on the ignition cylinder.

Positions of the key in the vehicle → Fig. 89

- ① Ignition switched off. The vehicle key may be removed.
- ② Ignition switched on.
- ③ Step on the brake pedal – (vehicles with automatic gearbox), or on the clutch pedal (vehicles with manual gearbox) and turn the engine on. When the engine catches on, release the ignition key. Upon release, the vehicle key returns to position → Fig. 89 ①.

Ignition-on indicator

According to the version of the vehicle, the ignition-on indicator may not be available.

When the driver door is opened with the ignition on, the warning **IGNITION ON**  may appear on the instrument cluster display in addition to an acoustic warning.

The acoustic warning is to remind the driver to turn the ignition off prior leaving the vehicle.

WARNING

Improper vehicle key use may cause severe injuries.

- Always take all vehicle keys with you when you leave the vehicle. The engine can be started and electrical equipment such as the window controls can be operated, which may lead to severe injuries.
- Never leave unattended children or people with special needs in the vehicle. They could become trapped in the vehicle in an emergency and may not be able to get themselves to safety. Depending on the time of year, for example, locked vehicles can be subjected to very high or very low temperatures. This can cause serious injuries and illness or fatalities, especially for small children.
- Never remove the vehicle key from the ignition cylinder while the vehicle is in motion.

NOTICE

With the ignition turned on and engine off, the battery of the vehicle may discharge and render a new start up of the engine impossible.

- Always turn off the ignition prior leaving the vehicle.

 In vehicles with automatic gearbox, if it is not possible to remove the vehicle key from the ignition lock with the vehicle stopped, move the selector lever to position **P**. If necessary, press and release the selector lever interlock button.

Starter button



Fig. 90 On the lower part of the centre console: engine start button.

The (Press & Drive) starter button replaces the ignition lock.

According to the vehicle version, the start button may not be available.

The vehicle's engine is started with the (Press & Drive) start button.

The vehicle can only be started when there is a valid vehicle key inside the vehicle.

Switching the ignition on or off

Press the start button once, without hitting the brake or clutch pedal → .

Automatic ignition turn off

When the driver moves away from the vehicle with the vehicle key and ignition on, the ignition will automatically turn off after some time. Should the dipped beam be turned on during this time, the side lights stay on for about 30 minutes. The side light can be turned off by locking the vehicle → page 63 or manually → page 79.

After the vehicle has detected that the driver is absent with the automatic engine turn off enabled, the ignition is automatically turned off after a given span of time.

WARNING

Unsupervised vehicle movements may cause severe injuries.

- To turn the ignition on, *do not* hit the brake or clutch pedal as this will immediately start the engine.

WARNING

Improper or unsupervised use of the vehicle keys can cause severe accidents or injuries.

- When leaving the vehicle, turn off your engine and always carry all the vehicle keys when leaving the vehicle. Whenever you lock your doors, make sure there are no people inside. Unauthorized people or children can lock the vehicle, start the engine or turn the ignition on and thereby operate the electric equipment such as, for example, the electric windows.







 When leaving the vehicle, always turn the ignition off manually or, should it be the case, observe the instructions on the instrument cluster display.

 Longer stopped periods with the ignition turned on may discharge the 12V vehicle battery to the point when it is no longer possible to start the engine.

 If, for example, the vehicle key battery is flat or very weak, the engine may not start with the start button. In this case use the emergency start function → page 107.

Start the engine

According to the vehicle version, the warm start system may not be available. In which case the indicator lamp of the heated start system  will not light up.

- *Vehicles with ignition lock*: rotate the vehicle key to → Fig. 89 . Ignition switched on. The warm starting system's indicator lamp  will then light up on the instrument cluster. Wait until the indicator lamp  is disabled, indicating the end of the fuel warming process (this action may be required when starting cold engines).
- *Vehicles with engine start button*: press the start button once. Ignition switched on. The warm starting system's indicator lamp  will then light up on the instrument cluster. Wait until the indicator lamp  is disabled, indicating the end of the fuel warming process (this action may be required when starting cold engines).
- Press and firmly hold the brake pedal pressed.
- *Vehicles with manual gearbox*: step on the clutch pedal and hold it firmly pressed until the engine is running. Position the gear selector lever into the neutral position.
- *Vehicles with automatic gearbox*: position the selector lever to position **P** or **N**.
- *Vehicles with ignition lock*: turn the vehicle key in the ignition lock to position → Fig. 89  – do not accelerate. When the engine catches, release the ignition key.
- *Vehicles with engine start button*: press the start button → page 104 – do not accelerate. To start the engine there must be a valid vehicle key in the vehicle's interior. When the engine catches on, release the start button.
- If the engine does not start, stop the procedure and repeat it after approximately one minute.

- *Vehicles with start button*: if necessary, execute the emergency start → page 107.
- Release the handbrake if you wish to pull away → page 121.

WARNING

The risk of serious injury can be reduced with the engine running or when starting the engine.

- Never start or run the engine in unventilated or closed spaces. The exhaust fumes contain carbon monoxide, an odourless and colourless poisonous gas. Carbon monoxide can cause loss of consciousness and death.
- Never leave the engine running if you leave the vehicle unattended. The vehicle could move suddenly or something unexpected may happen that may cause damage and serious injuries.
- Never use a start booster. A start booster can explode and cause the engine to suddenly run at high revs.

WARNING



Never leave the vehicle while the engine is running. The vehicle may move unexpectedly and cause severe accidents and injuries, especially with the selected gear or respective gear position.

NOTICE



- The starter engine or engine may be damaged when attempting to start the engine while driving or when the engine is started immediately after being switched off.
- While the engine is cool, avoid high rotations, total acceleration and increased engine load.
- Do not push or jump start the engine. Unburnt fuel may damage the catalytic converter.

 Do not leave the engine running when the vehicle is stationary. Immediately resume driving when there is good visibility in the windows; be careful not to force the engine while cold. This allows the engine to reach its operation temperature faster and reduces emissions.

 When starting the engine, major electrical consumers are switched off temporarily.

 When starting from cold, the engine may be a little noisy for a short period of time. This is quite normal, and no cause for concern. 

Stopping the engine

- The vehicle must be completely stationary → .
- *Vehicles with ignition lock*: rotate the vehicle key in the ignition lock to → Fig. 89 .
- *Vehicles with start button*: press the start button briefly → Fig. 90. If the engine won't stop, execute the emergency shut down → page 108.
- Observe the instructions on the instrument cluster → page 13.

WARNING

Never switch off the engine while the vehicle is in motion. This can lead to loss of control of the vehicle and cause severe accidents and injuries.

- The airbags and belt tensioners will not work if the ignition is switched off.
- The brake servo will not work when the engine is switched off. When the engine is switched off, greater force is required on the brake pedal to stop the vehicle.
- When the vehicle key is removed from the ignition lock, the steering lock may engage and it will no longer be possible to manoeuvre the vehicle.

WARNING

The components of the exhaust system become very hot. This can cause fires and serious injuries.

- Never park the vehicle so that parts of the exhaust system can come into contact with inflammable material underneath the vehicle, e.g. leaves, dry grass, spilt fuel, etc.
- Never apply underseal or anti-corrosion coatings to the exhaust pipes, catalytic converter, diesel particulate filter or the heat shields on the exhaust system.

NOTICE

If the vehicle has been driven at high load for a long period, the engine could overheat when it is switched off. In order to avoid damage to the engine, allow the engine to run in neutral for approximately 2 minutes before switching it off. 

i Vehicles with automatic gearbox, if it is not possible to remove the key from the ignition lock with the vehicle stopped, move the selector lever to position P. If necessary, press and release the selector lever interlock button.

i After the engine is switched off, the radiator fan in the engine compartment may run on for some minutes, even if the ignition is switched off or the vehicle key has been removed. The radiator fan will switch itself off automatically.

Electronic immobilizer

The immobilizer helps prevent the engine from being started and driven with an unauthorised vehicle key.

There is a chip in the key. It automatically deactivates the immobilizer when the vehicle key is inserted into the ignition cylinder.

The electronic immobilizer is automatically activated when the vehicle key is removed from the ignition lock → page 63. For vehicles with Keyless Access, the vehicle key must be outside the vehicle → page 63.

For this reason it is only possible to start the engine with a correspondently coded genuine Volkswagen vehicle key. Coded vehicle keys can be obtained at a Volkswagen Dealership. → page 60

i Proper vehicle operation is only guaranteed with genuine Volkswagen keys.

Troubleshooting

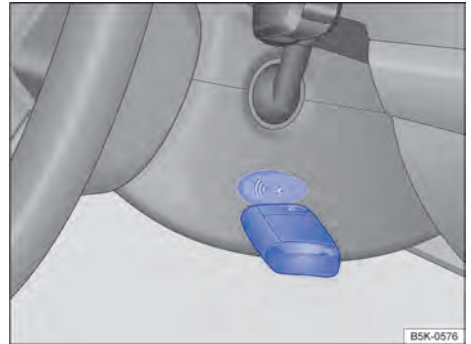



Fig. 91 To the right of the steering column: emergency start function of vehicles with Keyless Access locking and start system.

Instrument cluster indicator and warning lamps

The indicator and warning lamps are on:

EPC Engine management system fault (Electronic Power Control). The engine must immediately be checked at a Volkswagen Dealership.

 Faulty emissions in the exhaust system (OBD). Reduce your speed. Carefully drive to the nearest Volkswagen Dealership. The engine must be checked.

Unauthorized vehicle key

When an unauthorized vehicle key is inserted in the ignition lock it can be removed as follows:

- Vehicles with manual gearbox: remove the key from the ignition lock.
- Vehicles with automatic gearbox: press and release the interlock button on the selector lever. Remove the vehicle key from the ignition lock.

Emergency start function

When no valid vehicle key inside the vehicle is detected, execute the emergency start function. A corresponding indicator will come up on the instrument cluster display. This can be the case when, for example, the vehicle key battery is weak or discharged.

- Press and hold the brake pedal.
- Hold the vehicle key after pressing the start button directly to the right of the steering column → Fig. 91.
- The ignition is automatically turned on, and, if the case, the engine is started.

Emergency shut down

When the engine does not stop when the start button is briefly pressed, the emergency shut down needs to be executed:

- Press the start button twice within a few seconds or keep it pressed once for a long time.
- The engine automatically shuts down → ⚠ in *Starter button* on page 105.

Immobiliser malfunction

When an invalid vehicle key is used or when the system is damaged, a corresponding indication pops up on the instrument cluster display. The engine will not be able to be switched on. Use a valid vehicle key or visit a Volkswagen dealership. ◀

Start-Stop System

Start-Stop system

Depending on the vehicle or the radio version, the Start-Stop system may not be available.

The Start-Stop system automatically turns off the engine after stopping the vehicle and during the vehicle stopping stages. If necessary, the engine automatically starts up again.

Turn on the Start-Stop system

The function is automatically enabled whenever the ignition is switched on. The instrument cluster display shows information regarding the current status.

Other information regarding the Start-Stop mode can be accessed on the radio display. On the main radio screen, swipe left once and select Vehicle status.

When crossing through flooded areas, always manually turn the Start-Stop system off.

Indicator lamps

When the  indicator lamp is on, it indicates that the Start-Stop system is on and the automatic engine stop is active.

When the  indicator lamp is on, the Start-Stop system is not available or the engine was automatically started by the Start-Stop system → page 108.

The Start-Stop system's status is shown on the instrument cluster display.

Deactivate and activate the Start-Stop system automatically

- To stop the vehicle, step on the brake pedal and keep it pressed. Shortly before the vehicle stops or upon stopping, the engine shuts down.
- To start the engine up again, remove foot from the brake pedal or step on the accelerator.

Important conditions for the automatic engine shutdown to work

- The driver must fasten the seat belt.
- The driver's door must be closed.
- The bonnet must be closed.
- A minimum engine temperature must be reached.
- *Vehicles with Climatronic*: the vehicle interior temperature is within the set temperature range and the humidity is not too high.
- The air conditioning defrost function must be off.
- The 12-V vehicle battery must have enough charge.
- The 12-V vehicle battery's temperature must not be too high or too low.
- The vehicle is not on a steep up- or downhill incline.
- *Vehicle with automatic gearbox*: the steering wheel is not intensely turned.
- The reverse gear must not be engaged.

If the automatic engine shutdown conditions are only reached during a stop, the engine will shut down subsequently, for example, upon turning off the defrost function.

Conditions for a new automatic start

The engine can start automatically under the following conditions: ▶



- If the vehicle interior gets too hot or too cold.
- When the vehicle starts moving.
- When the 12 V battery charge is low.
- When the steering wheel is moved.

Drive on function

When a valid vehicle key is not detected inside the vehicle after turning the engine off, it is possible to start the engine again within five seconds. A corresponding message will be displayed on the instrument cluster.

After this short period of time it is no longer possible to start the engine without a valid vehicle key inside the vehicle.

Manually enable and disable the Start-Stop system

- Press  on the centre console **OR** on the radio display to manually disable the system. If the Start-Stop is disabled, the indicator light appears on the button.
- Press  on the centre console **OR** on the radio display again to manually enable the system.

Whenever the  button is pressed, the instrument cluster display will indicate the Start-Stop system status.

If the engine was shut down by the Start-Stop system, it will start up again as soon as the system is disabled by pressing the  button.

When crossing through flooded areas, always manually turn the Start-Stop system off.

WARNING

Improper or unsupervised use of the vehicle keys can cause severe accidents or injuries.

- When leaving the vehicle, turn off your engine and always carry all the vehicle keys when leaving the vehicle. Whenever you lock your doors, make sure there are no people inside. Unauthorized people or children can lock the vehicle, start the engine or turn the ignition on and thereby operate the electric equipment such as, for example, the electric windows.

WARNING

Never switch off the engine while the vehicle is in motion. This can lead to the loss of control of the vehicle, to severe accidents and injuries.

- The airbags and belt tensioners will not work if the ignition is switched off.
- The brake servo will not work when the engine is switched off. A stronger action on the brake pedal is required to stop the vehicle.
- Steering assistance is maintained when the vehicle's engine is turned off by Start-Stop.
- When working in the engine compartment the Start-Stop system must be disabled.

NOTICE

If the Start-Stop system is used for an extended period of time at excessively high exterior temperatures, the 12-V battery may be damaged.

 In some cases, the engine has to be manually restarted. Follow the message shown on the instrument cluster display.

 For vehicles with selectable driving profile, when the **Eco** profile is selected the Start-Stop system is automatically enabled.

 When crossing through flooded areas, always manually turn the Start-Stop system off.

Troubleshooting

The engine does no longer start automatically

If the engine no longer starts automatically, the alert **Fault: vehicle power system**. Go to a workshop. May be displayed on the instrument cluster display.

- Manually start the engine → page 105.
- Manually turn off the Start-Stop system.
- Immediately seek assistance from a Volkswagen Dealership or a qualified workshop.

Manual gearbox

Manual gearbox: engaging the gear

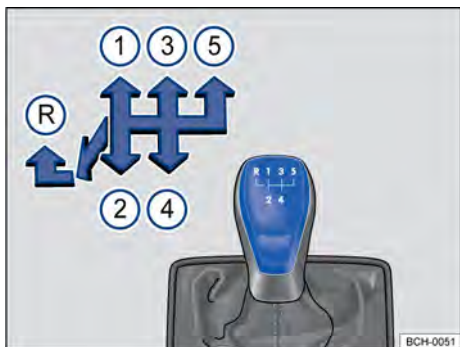

Fig. 92 Gear shift pattern of a 5-speed manual gearbox.

Depending on the vehicle version, the design of the gearshift lever may vary.

Engaging a forward gear

Each gear position is illustrated on the gear lever → Fig. 92.

- Fully depress and hold the clutch pedal.
- Position the gear selection lever into the neutral position → ⚠.
- Gently release the clutch pedal to start moving.

Volkswagen recommends stepping fully on the clutch pedal to start the engine.

Selecting reverse gear

- Reverse gear should only be selected when the vehicle is stationary.
- Fully depress and hold the clutch pedal → ⚠.
- Move the gear lever to the neutral position and push down.
- Push the gear lever fully to the left and then to the front in the reverse gear position → Fig. 92 Ⓡ.
- Gently release the clutch pedal to start moving.

Shifting down gears

You should always select the next immediate gear when shifting down a gear whilst the vehicle is in motion. Engine revs should not be too

high when doing so → ⚠. The clutch, gearbox and engine may be damaged if one or more gears are skipped when shifting down a gear at high speeds or high engine revs, even if the clutch is not released in the process → Ⓡ.

⚠ WARNING

When the engine is running, the vehicle will start to move as soon as a gear is engaged and the clutch released.

- Never switch off the engine while the vehicle is in motion.
- Never select reverse gear while the vehicle is in motion.

⚠ WARNING

Shifting gears incorrectly to a lower gear can lead to a loss of control of the vehicle, which can cause accidents and serious injuries.

ⓘ NOTICE

The clutch, gearbox and engine may be severely damaged if the gear stick of the manual gearbox is shifted to a gear which is too low when travelling at high speeds or at high revs. This also applies if the clutch remains depressed and the gears do not engage.

Trouble shooting

According to vehicle version, some indicator lamps may not be available.



The clutch does not support the full engine torque. If it is the case, take foot off the clutch pedal.



The clutch may get very hot, for example, from frequent pulling away, "slow driving" or heavy stop-and-go traffic. Its overheating is indicated by the warning lamp and, if it is the case, by additional warning lamps, as well as by a text message displayed on the instrument cluster display. Moreover an acoustic alarm may also be sounded → ⓘ.



The clutch is defective. **Proceed carefully!** Go to a Volkswagen Dealership or qualified workshop. Otherwise, severe damages may occur to the clutch.

NOTICE

Please note the following points in order to avoid damage and premature wear:

- Do not rest your hand on the gear lever when driving. The pressure from your hand is passed onto the selector forks in the transmission.
- Ensure that the vehicle has come to a full stop before engaging reverse gear.
- Always fully depress the clutch pedal when changing gear.
- Do not hold the vehicle by "riding" the clutch on a hill with the engine running.

Automatic gearbox

Automatic gearbox: engaging gears

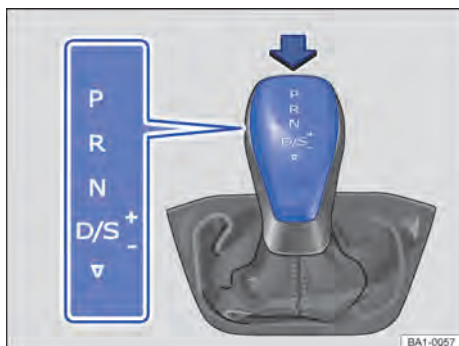

Fig. 93 Automatic gearbox selector lever with interlock button (arrow).

According to the vehicle version, the automatic gearbox may not be available.

The engaged gear or gearbox driving programme is indicated on the instrument cluster when the ignition is on.

P – Parking lock

The traction wheels are mechanically blocked. Engage only while the vehicle is *stationary*. To move the selector lever from its position with the ignition turned on, actuate the brake pedal and press the interlock button on the selector lever.

R – Reverse gear

Reverse gear engaged. Engage only while the vehicle is *stationary*.

N – Neutral

The gearbox is in the neutral position. No force is transmitted to the wheels and the braking effect of the motor is not available.

D/S – Permanent forward driving position

Position D: normal style program

All forward gears are shifted up and down automatically. The timing of the gear shift is determined by the engine load, your individual driving style and the speed of the vehicle.

Position S: sport style driving program

The gear levels are increased *later* and reduced *earlier* than when in **D** position to make the best use of the power reserves of the engine. The timing of the gear shift is determined by the engine load, your individual driving style and the speed of the vehicle.

Move the selector lever backwards ▽ → Fig. 93 to switch between position **D** and **S**.

In this, the selector lever will always elastically return to the **D/S** position. This also works for the Tiptronic gate → page 112.

Selector lever lock

In position **P** or **N**, the selector lever lock prevents an accidental selector move that would involuntarily put the vehicle in motion.

To release the selector lever lock with the ignition on, push the brake pedal down and keep it pressed. At the same time, press the selector lever lock button into the direction indicated by the arrow → Fig. 93.

For fast gear change passing through the **N** position, for example, from **R** to **D/S**, the selector lever is not locked. Thereby it is possible to "rock" a vehicle back and forth out of a bog. The selector lever lock engages when, with the brake pedal released, the lever lingers in the **N** position for over about a second and at a speed of less than about 5 km/h.

WARNING

Engaging an incorrect selector lever position may lead to the loss of control of the vehicle, accidents and severe injuries.

- Never depress the gas pedal when selecting a gear.
- When the engine is running and the selector is in a drive position, the vehicle will start moving as soon as the brake pedal is released.
- Never move the selector lever to reverse or to **P** while driving.

⚠ WARNING

Unsupervised vehicle movements may cause severe injuries.

- The driver must never leave the driver seat if the engine is running and a gear has been selected. If you have to leave the vehicle while the engine is running, always firmly apply the handbrake and move the selector lever to position **P**.
- With the engine running and the selector lever engaging position **D/S** or **R**, it is necessary to step on the brake to keep the vehicle stationary. Even when the engine is idling, the vehicle will “creep forward/backward” as the power transmission is not fully interrupted.
- Never move the selector lever into **P** with the vehicle in motion.
- Never leave the vehicle with the selector lever in position **N**. The vehicle will roll downhill regardless of whether or not the engine is running.

ⓘ NOTICE

When, with the vehicle stationary, the handbrake is **not** engaged and the brake pedal is released with the selector lever in position **P**, the vehicle can still roll a few centimetres back and forth.

ⓘ If while driving, the **N** position is accidentally selected, let go off the accelerator. Await the engine idle rotation in neutral position before selecting a different gear.

Shifting gears with the Tiptronic

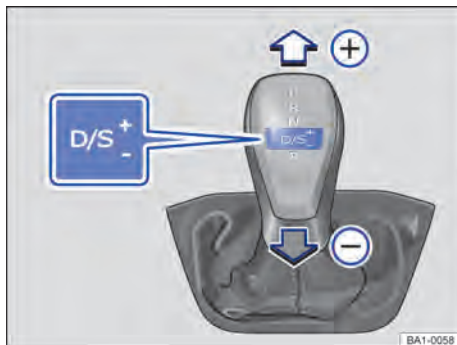

Fig. 94 Selector lever in Tiptronic position.



Fig. 95 Steering wheel with Tiptronic gear shift paddles.

With the automatic gearbox, the gears can be manually stepped up or down with the Tiptronic.

Operating the Tiptronic with the selector lever

- In position **D/S**, move the lever to the right up to the Tiptronic gate.
- Move the selector lever forward **⊕** or backward **⊖** to increase or decrease the speed → Fig. 94.

Operating the Tiptronic with the shift paddles

- Pull the right steering wheel paddle lever → Fig. 95 to step up the gears.
- Pull the left steering wheel paddle lever to step down the gears.
- Pull the right shift paddle towards the steering wheel for about one second to disable the Tiptronic.

The Tiptronic is automatically disabled when the shift paddles are not used for a while or the selector lever is not in the Tiptronic gear.

NOTICE

- When accelerating, the gearbox automatically shifts up to the next gear shortly before the maximum permitted engine speed is reached.
- When shifting down a gear manually, the gearbox will not change gear until the engine can no longer be overrevved.

Driving with automatic gearbox

Forward gears are shifted up and down automatically.

Driving downhill

The steeper the gradient, the lower the gear you will need. Lower gears increase the braking effect of the engine. Never allow the vehicle to roll down mountains or hills in the neutral position **N**.

- Reduce your speed.
- Press the selector lever from position **D/S** to the right in the direction of the Tiptronic gate → page 112.
- Gently push the selector lever to the rear to change down gear.
- **OR:** reduce the gear speed with the shift paddles on the steering wheel → page 113.

Stopping and proceeding uphill

The steeper the gradient, the lower the gear you will need.

When stopping on an uphill slope with engaged gear, the vehicle must always be prevented from moving by stepping on the brake pedal or engaging the handbrake. Release the brake or handbrake only upon pulling away → ⓘ.

Kick-down

The kick-down function allows maximum acceleration with the selector lever in position **D/S** or in the Tiptronic position.

Upon fully stepping down on the accelerator, the automatic gearbox engages a lower gear. This will make use of the full vehicle acceleration → ⚠.

With the kick-down, the automatic increase to the next gear occurs only when the maximum prescribed engine rpm is reached.

In vehicles with driving mode selection, if the **Eco** → page 117 driving mode is selected and the accelerator is pressed beyond the pressure point, until the floor, the engine power is automatically regulated to ensure maximum vehicle acceleration.

WARNING

A rapid acceleration can cause loss of traction and skidding, particularly on slippery roads. This can lead to loss of control of the vehicle, severe accidents and injuries.

- Always adjust your driving style in accordance with the flow of traffic.
- The Kick-Down function or fast acceleration must only be used visibility, weather, road and traffic conditions permitting and other road users are not compromised due to the vehicle acceleration and driving style.

WARNING

Never “ride” the brake pedal. Do not overuse the brake pedal. Constant braking will cause the brakes to overheat. This can considerably reduce the brake effect, increase the braking distance and, in certain circumstances, cause the brake system to fail completely.

NOTICE

- If you stop the vehicle on an incline, do not attempt to stop it from rolling back by depressing the accelerator when a gear has been selected. This may overheat and damage the automatic gearbox.
- Never allow the vehicle to roll with the selector lever in position **N**, particularly when the ignition is switched off. The automatic gearbox is not lubricated and can be damaged.

NOTICE

- Never let the brakes “slip” by applying light pressure to the brake when it is not really necessary to brake. This will increase wearing.
- Before driving down a long, steep downhill gradient, reduce the speed and change to a lower gear. This will make use of the braking effect of the electric drive and relieve the load on the brakes. The brake system could otherwise overheat and fail. Only use the brakes when necessary to slow down or stop the vehicle.

Troubleshooting

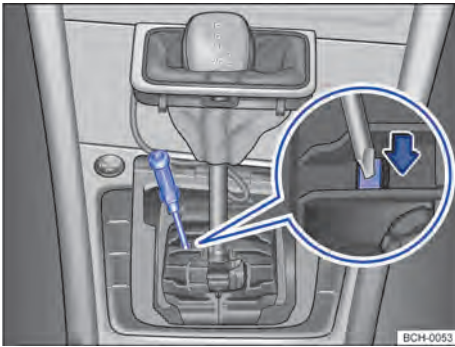





Fig. 96 Remove the selector lever cover and manually emergency unlock the selector lever lock.

Warning and indicator lamps on the instrument cluster

The indicator lamps light up.

  **Stop driving!** Gearbox damaged. Let the gearbox cool down with the selector lever in position **P**. If the warning does not turn off, do not drive on and seek specialized technical assistance. Otherwise the gearbox may suffer severe damage.

 Brake pedal not pressed, for example, during an attempt to select another gear position with the selector lever. Step on the brake pedal to select a gear.

The indicator lamps flash.

 The interlock button of the selector lever is not pressed. The pull away is impeded. Engage the lock of the selector lever lock → page 111.

Selector lever troubleshooting

 On rare occasions the selector lever lock may not engage on vehicles with automatic gearbox. The drive is then deenergized to prevent an unsupervised pull away. The indicator light flashes and, in addition, an informative text is displayed. To engage the selector lever lock, proceed as follows:

- press the brake pedal and release the pedal again.

Emergency unlocking the selector lever

Should the vehicle need to be towed during a failure of power supply, for example, a flat 12 V vehicle battery, an emergency unlocking of the selector lock lever will have to be performed. Seek expert assistance for this.

The emergency unlock is located underneath the selector lever frame cover.

Removing the selector lever cover

- Apply the handbrake.
- Switch off the ignition.
- Carefully pull the cover with the electric cables connected upward in the area of the selector lever trim.
- Double the cover up over the selector lever → .

Emergency unlock the selector lever lock

- With the help of a screwdriver carefully press the release lever in the direction indicated by the arrow and keep it in that position → Fig. 96.
- Press the interlock button on the selector lever and move the lever to the **N** position.
- After emergency unlocking, reinstall and carefully press the cover on the centre console, paying attention to the correct position of the electric cables.

Emergency program

The system is damaged when all selector lever position indicators are highlighted by a light background on the instrument cluster display. The automatic gearbox operates under an emergency programme. Under the emergency program the vehicle can still run, however at reduced speed and not in all gears.

With automatic gearbox, in some cases **it will no longer be possible to drive in reverse gear.** ▶

In all cases, the automatic gearbox must immediately be checked by a Volkswagen Dealership.

Automatic gearbox overheating



The automatic gearbox may get very hot, for example, from frequent pulling away, "slow driving" or heavy stop-and-go traffic. Its overheating is indicated by the warning lamp and, if it is the case, by a text message on the instrument cluster display. An acoustic alarm may also be sounded. Stop the vehicle and wait until the transmission cools down → ①.

The vehicle does not move backward nor forward despite the engaged gear level

If the vehicle does not move in the desired direction, the gear position may not be properly engaged. Next, step on the brake pedal and select the desired gear once again.

If the vehicle still does not move to the desired location, the system is faulty. Seek specialized technical support and inspect the system.



WARNING

Never take the selector lever out of the **P** position while the handbrake is not engaged. Otherwise, on slopes, the vehicle may roll away unexpectedly and thereby cause severe accidents and injuries.



NOTICE

When the vehicle is driven for a longer period with the engine turned off and the selector lever in position **N**, or at a higher speed, the automatic gearbox will be damaged, for example, when being towed.



NOTICE

- As soon as the transmission overheating is shown for the first time, the vehicle must be safely parked or driven at speeds above 20 km/h.
- When the text message and the acoustic warning are repeated every 10 seconds, the vehicle must be stopped safely immediately and the engine shut off. Wait until the transmission cools down.

- To prevent damage to the gearbox, drive-on only when the acoustic alarm is no longer sounded. While the transmission is overheated, starting the vehicle or driving at walking speeds must be avoided. <

Uphill assist system

The uphill assist system (HHC - Hill Hold Control) assists the driver with pulling away uphill, by holding the vehicle.

The uphill assist system is automatically enabled under the following circumstances

Vehicles with manual gearbox

The following conditions must be **simultaneously** met:

- ① Keep the vehicle **stopped** with the brake pedal on an uphill gradient of about 5%.
- ② The engine runs "in a regular way".
- ③ Step fully on the clutch pedal and engage the gear shift lever in the **1st gear** to drive uphill forward, or in the **R** position to drive uphill in reverse gear.

To pull away, take foot off the brake pedal and at same time release the clutch pedal (engage) and accelerate as needed. **Upon releasing the brake pedal, the vehicle is held in place for approximately 2 seconds. The brake is slowly released upon starting. If starting does not occur within two seconds, the brake is released and the vehicle will move backwards.**

Vehicles with automatic gearbox

The following conditions must be **simultaneously** met:

- ① Keep the vehicle **stopped** with the brake pedal on an uphill gradient of about 5%.
- ② The engine runs "in a regular way".
- ③ With the selector lever in position **D/S** to drive forward up hill or in position **R** to drive in reverse up hill.

To pull away, take foot off the brake pedal and accelerate as needed. **The brake is slowly released upon starting.** ►

The uphill assist system is immediately disabled:

- If any of the aforementioned conditions are no longer available → page 115, *The uphill assist system is automatically enabled under the following circumstances.*
- When the driver door is opened.
- In case of irregular running of the engine or deficiencies in the engine.
- When the engine is turned off or "dies".

Adverse conditions:

The electronic stability program (ESC) may not identify very steep slopes (over 30%). This circumstance may affect the regular operation of the electronic stability program (ESC) and consequently the hill assist system (HHC - Hill Hold Control), emergency braking assistant (Front Assist) and parking sensor.

To restore the aforementioned systems, it is sufficient that the vehicle is turned off and on again and that the driver starts the car and drives it at a speed greater than 25 km/h for a few seconds.

CAUTION

- When the vehicle does not pull away immediately after the brake pedal is released, it may eventually roll backwards. In this case immediately hit the brake pedal or pull the handbrake.
- If the engine quits, step immediately on the brake pedal or pull the handbrake.
- When on an uphill slope with intense traffic, to prevent the vehicle from rolling backward when pulling away, step on the brake for some minutes.

Steering assistance

Information on steering

Electromechanically assisted steering consumes less power from the vehicle in comparison to hydraulically assisted steering wheels, as it is activated only when the steering wheel is turned, while with the hydraulically assisted steering, the hydraulic system is always being run, even with the vehicle moving straight ahead. With the electromechanically assisted steering a computerized

control unit associated with an electric motor, sensors and a gear box replaces the hoses, pump, reservoir and fluid of a hydraulic system.

The electromechanical power steering assist is automatically adjusted based on the driving speed, the torque and the angles applied by the conductor on the wheel to turn the vehicle. The electromechanical assist only works when the engine is running.

When the electromechanical assist is reduced or malfunctioning, a lot higher strength than usual will be required to manoeuvre the vehicle. But never will the driver lose control over the steering wheel of the vehicle.

For vehicles with selectable driving profile the behaviour of the electromechanical steering assistance can be influenced through the selected driving profile.



WARNING

- The electromechanical power steering assist only works when the engine is running. In case of engine malfunction while the vehicle is moving, the electromechanical assist works for some time longer in order to safely park the vehicle.
- Never allow the vehicle to roll if the engine is switched off.
- Never remove the vehicle key from the ignition cylinder while the vehicle is in motion.

Troubleshooting

Warning and indicator lamps on the instrument cluster

When switching the ignition on, certain warning and indicator lamps light up briefly to check their functions and turn off after a few seconds. If the lights turn on again:

-   **Stop driving!** Electromechanical steering assist out of action. Contact a Volkswagen Dealership immediately.
-  Electromechanical steering assist with limited operation. Contact a Volkswagen Dealership as soon as possible.

Driving mode selection

Introduction

The driver can adjust several features of the vehicle systems to the current driving conditions, the desired driving convenience, and a fuel saving driving style using the driving profiles. Among the vehicle's systems that can be adjusted are the running gear, engine control, and air conditioning.

Depending on the vehicle version, different driving modes are available for selection. The influence of vehicle systems in individual driving modes depends on the vehicle version.

Select driving mode

Depending on the vehicle version, the driving profile selection may not be available or may vary.

The profile can be selected with the ignition on and the vehicle stopped or while driving → .



If a driving mode is selected while driving, the vehicle's systems immediately switch to the new mode, except the engine.

- When traffic permits, quickly remove foot from accelerator pedal to allow the selected driving mode to be applied to the engine as well.

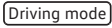

Select the driving mode on the radio display

- ① Switch on the ignition.
- ② On the main radio screen, swipe left once and select .
- ③ Select the desired driving profile on the radio display.

Show information in the driving mode.

- It is possible to access information about the driving profiles, except the driving profile .
- To show more information on the selected driving mode, touch  on the radio display.

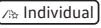





Select the "Individual" driving mode

- Touch the  driving mode on the radio display.
- Touch  to open the menu.
- In the menu, configure **Transmission**, **Engine sound**, **Steering** and **Air conditioning**, as desired.
- To reset to default settings, touch .

 **WARNING**
Adjusting driving modes while driving may distract drivers and cause accidents.

- Always drive carefully and responsibly. 

Characteristics of driving modes

-  **Eco**: places the vehicle in low consumption mode and promotes economical driving. In the **Eco** driving mode, the gear position is switched automatically to free wheel function. 
-  **Normal**: the driving mode represents basic settings of vehicle systems and offers a moderate combination, for example, for day-to-day use.
-  **Sport**: provides a sporting feeling to the driving experience and can change the engine sound. In the **Sport** driving mode, in vehicles with automatic gearbox, the selector lever position is automatically switched to position **S**.
-  **Individual**: vehicle systems can be customized. 

Default behaviours of driving modes and vehicle systems

With the ignition off, the **Normal** driving mode represents basic settings of the vehicle systems.

Behaviour of driving modes when switching the ignition off and on again

When switching the ignition off and on again, the last driving mode selected remains active. 

Vehicle systems or driving mode do not behave as expected

Observe the default behaviours of vehicle systems or driving modes → page 117.

Driver assist systems

Cruise control system (GRA)

Introduction

The speed regulator system (GRA) assists the driver keeping constant a set speed.

Depending on the vehicle version, the cruise control (GRA) may not be available.

Speed range

The GRA is available for forward driving from 20 km/h onwards.

Display indicators

If the GRA is switched off, the instrument cluster display will show the stored speed and the GRA status:



GRA on.



Displayed small or grey: GRA not regulating.



Displayed large or white: GRA on, active regulation.

If no speed is stored, the instrument cluster display will show ---.

Changing gear

As soon as the clutch pedal is stepped on, the cruise control is interrupted and automatically taken up again after the gear change.

Driving downhill

When driving downhill the set speed may be exceeded due to the slope gradient.

To maintain speed, lower the gear or press the brake pedal. The GRA is disabled when the brake pedal is pressed.

How do I control the GRA?

The GRA is controlled through the multifunction steering wheel → page 119. ▶

⚠ WARNING

When it is not possible to drive safely over a sufficient distance and at a constant speed, the cruise control system may cause severe accidents and injuries.

- Never use the cruise control system (GRA) in intense traffic, over short distances, steep, sinuous, and slippery circuits, such as ice, snow, humidity, or gravel and also not on flooded roads.
- Never use the GRA in free terrain or unpaved roads.
- Adjust the speed and safety distance to vehicles ahead based on weather, road, and traffic conditions.
- In order to prevent unexpected speed adjustments, always switch off the GRA after using.
- It is dangerous to resume stored speeds if the speed is too high for current road, traffic, or weather conditions.
- On downhill slopes, the GRA may not keep the vehicle speed constant. The vehicle's weight increases speed by itself. Reduce the gear or apply the brakes.

Operating the GRA by way of multifunction steering wheel

📖 Please refer to ⚠ at the start of the chapter on page 119.

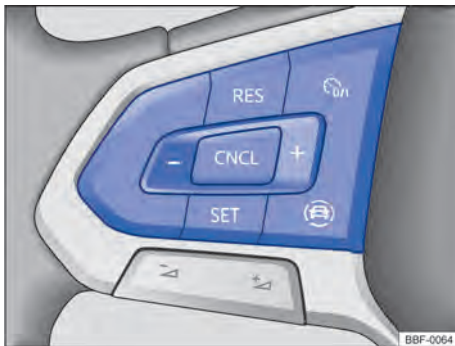

Fig. 97 Left side of the multifunction steering wheel: GRA operating buttons.

Switch on

- Press .

No speed is saved and no control is yet active.





Starting the cruise controlling



- While driving, press .

The current speed is saved and controlled. In addition the green indicator lamp lights up .

Set speed

The saved speed may be adjusted while the GRA is controlling:

-  + 1 km/h
-  - 1 km/h
-  + 10 km/h
-  - 10 km/h

To alter the set speed continuously, keep the  button or the  button pressed. The system adjusts the current speed accelerating or slowing down the vehicle accordingly. The vehicle does not actively brake.

Interrupting the control

- Briefly press the  button or the  button. Or step on the brake as an alternative.

The speed will remain stored.

Resume operation



- Press the .

The current speed is resumed and adjusted.

Switch off

- Press the  button for a moment.

The GRA is turned off and the saved speed deleted.

 The  button does not have any function for GRA.

Troubleshooting

📖 Please refer to ⚠ at the start of the chapter on page 119.

🔧 Damaged GRA

- Volkswagen recommends seeking out a Volkswagen Dealership

The cruise control is automatically interrupted.

Several causes are possible:

- The driver has hit the brake.
- The vehicle exceeded the set speed over a longer time period.
- System malfunction. Disable the GRA and have it checked at a Volkswagen Dealership. ◀

Parking and manoeuvring

Parking

Stopping the vehicle

Always park the vehicle in the indicated sequence.

Park the vehicle always on a level and stable surface → ⚠.

- Stopping the vehicle. With a manual gearbox, press the clutch pedal *fully* down.
- Depress and hold the brake pedal until the engine has stopped.
- With an *automatic gearbox*, move the selector lever to position **P**.
- Lift the handbrake lever up → page 121.
- Switch off the engine. The Ⓜ indicator lamp on the instrument cluster should be lit up in *red*.
- Remove the key from the ignition.
- In vehicles with manual gearbox, select 1st gear for flat ground and uphill inclines, or reverse gear for downhill inclines, and then release the clutch.
- Let go off the brake pedal.
- Ensure that all occupants, particularly children, have left the vehicle.
- Take all vehicle keys with you when you leave the vehicle.
- Lock the vehicle.

Parking on uphill and downhill slopes

Before switching off the engine, turn the steering wheel so that the front wheels will roll against the kerb if the parked vehicle starts to move.

- When facing downhill, turn the wheels so that they face the kerb.
- When facing uphill, turn the wheels so that they face the centre of the road.

WARNING

The components of the exhaust system become very hot. This can cause fires and serious injuries.

- Never park the vehicle so that parts of the exhaust system can come into contact with inflammable material underneath the vehicle, e.g. leaves, dry grass, spilt fuel, etc. ▶

⚠ WARNING

Leaving and parking the vehicle incorrectly may cause the vehicle to move. This could lead to accidents and severe injuries.

- Ensure that the handbrake is correctly engaged.
- Never remove the vehicle key from the ignition cylinder while the vehicle is in motion.
- Always take all vehicle keys with you when you leave the vehicle. The engine can be started and electrical equipment such as the window controls can be operated, which may lead to severe injuries.
- Never leave unattended children or people with special needs in the vehicle. They could become trapped in the vehicle in an emergency and may not be able to get themselves to safety. Depending on the time of year, for example, locked vehicles can be subjected to very high or very low temperatures. This can cause serious injuries and illness or fatalities, especially to small children.

! NOTICE

- Only release the brake pedal after pulling the handbrake, in order to prevent sudden vehicle movement after parking.
- Drive carefully in parking lots with long kerbs or fixed posts. Objects higher than the ground level may damage the bumper and other vehicle parts when parking. In order to avoid any damage, stop the vehicle before the wheels touch the bollards or kerbs.
- Carefully drive through entrances and slumps in terrains, ramps, kerbs, and other objects. Lowered vehicle parts, such as the bumper, spoiler and chassis, engine or exhaust parts may be damaged in these situations.

i Please adhere to relevant legislation when stopping and parking your vehicle.

Handbrake

Engaging the handbrake

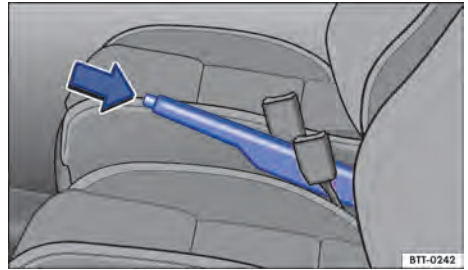



Fig. 98 Between front seats: handbrake lever.

Always pull the handbrake lever when leaving or parking the vehicle.

Applying the handbrake

- Press the interlock button and pull the handbrake lever upwards → Fig. 98 (arrow).

The handbrake is engaged when the  indicator lamp, with switched on ignition, lights up on the instrument cluster.

Releasing the handbrake

- Pull the handbrake lever slightly upwards and press the interlock button → Fig. 98 (arrow).
- Guide the handbrake lever down while pressing down the interlock button.

⚠ WARNING

Incorrect use of the handbrake can cause severe accidents and injuries.

- The handbrake should never be used to brake the vehicle, except in emergencies. The braking distance is considerably longer as only the rear wheels are braked. Always use the foot brakes.
- Never drive with the handbrake lever slightly pulled. This could overheat the brake and compromise the braking system. In addition, this causes premature wearing of rear brake pads.
- Never drive the vehicle with the handbrake lightly applied. The vehicle can move even while the handbrake is applied.

NOTICE

Only release the brake pedal after pulling the handbrake, in order to prevent sudden vehicle movement after parking.

Parking systems safety instructions

The following are parking systems:

- Park Distance Control → page 122.
- Rearview camera system → page 125

Which of the listed systems is installed will depend on the version of the vehicle.

Limits of parking systems

Objects such as thin poles and bars, fences, trees, very low or high obstacles as well as open or opening boot lids may not be detected by the sensors or cameras.

In some cases dirt or ice covering the sensors or cameras may be taken for an obstacle.

Limits of the reverse camera

The rear view camera only shows two-dimensional images on the display. Due to the absence of image depth, protruding objects or recesses in the road may be difficult to identify or not be identifiable at all.

The orientation lines are superimposed on the image regardless of the surroundings of the vehicle, there is no automatic identification of objects. The driver is responsible for the assessment of whether the vehicle fits or not into the parking space.

WARNING

The intelligent technology shipped with the parking systems cannot go beyond the limits imposed by physics and will only operate within the limitations of the system. The increased convenience provided by the parking assist systems must not let you ignore a risk situation. The parking assist systems cannot replace the driver's full attention.

- Adapt your speed and driving style to suit visibility, weather, road and traffic conditions.

- Unsupervised vehicle movements may cause severe injuries.
- Always keep in mind the parking direction and the relevant areas around the vehicle.
- Do not let your attention be deviated from the surrounding traffic by the images displayed on the instrument cluster display or on the radio system.
- Always keep your attention on the surroundings of the vehicle as small children, animals and objects are not always detected by the parking systems.
- The parking systems have blind spots in which obstacles and people cannot be detected.
- External acoustic sources and certain object surfaces and clothing may influence the sensor signals. Under certain circumstances people and objects may not be detected or mistakenly detected.
- Due to the display's resolution and in conditions of insufficient lighting, certain objects, such as thin posts or fences, may not be displayed at all or only partially so.
- The signals and indications of the parking systems demand a reaction time with a too fast approximation may not be sufficient to emit a warning.

 Volkswagen recommends practicing the use of the parking distance control in a low-traffic area or a parking lot to get properly acquainted with the system's quirks.

Park distance control (Park Pilot)

Introduction

The park distance control system assists the driver with parking and manoeuvring.

According to the vehicle version, the park distance control system may not be available.

By way of sensors in the front and rear bumper the parking assist determines the distance of an obstacle from the vehicle → page 6. The system indicates on the radio system through acoustic signals when there is an obstacle in the sensors' detection range.

System limitations

Objects such as towing bars, thin poles and bars, fences, trees, very low or high obstacles as well as open or opening boot lids may not be detected by the sensors.

In some cases dirt or ice covering the sensors may be taken for an obstacle.

Enabling and disabling



Fig. 99 On the centre console or on the radio display: button for turning the parking aid on and off.

Depending on the vehicle or radio version, the button to enable and disable park distance control may not be available.

Enabling the park distance control

- Selecting reverse gear.
- **OR:** on the centre console press the **[P_{PA}]** button **OR** on the radio display touch the **[P_{PA}]** button.

The park distance control is automatically enabled when the vehicle moves in reverse gear.

According to the vehicle version, the park distance control system may also be enabled automatically.

Disabling the Park Distance Control

- On the centre console press the **[P_{PA}]** button **OR** on the radio display touch the **[P_{PA}]** button.
- **OR:** accelerate the vehicle forward at a speed higher than approximately 0 to -15 km/h.

Automatic enabling (version dependent)

The Park Distance Control is also enabled when the vehicle is driven at a speed of less than 15 km/h against an obstacle in the front area. Automatic activation can be enabled on the radio system.

The automatic activation only works when the approximate speed of 15 km/h is not reached is not reached for the first time. A new automatic activation is possible when the Park Distance Control is disabled and enabled again by means of the **[P_{PA}]** button on the centre console **OR** on the radio display.

Further, the automatic activation can also be enabled again by switching the ignition off and on again.

Manoeuvre braking

When the vehicle is equipped with the manoeuvre braking function, the manoeuvre braking will activate an emergency braking as soon as an obstacle is detected while driving in reverse gear. The purpose of the manoeuvre braking is to reduce the possibility of a collision. For such, the speed must not exceed 10 km/h; The manoeuvre braking function is enabled or disabled when park assist is on or off. The manoeuvre braking is inactive for 5 meter after a braking in the same direction and, after a gear change or gear position change, the manoeuvre braking is again ready to brake. The Park Distance Control limitations apply.

The manoeuvre braking is not active when the Park Distance Control was automatically activated.

Touch the **[M_{AB}]** function button to enable or disable the manoeuvre braking.

Representation on the display

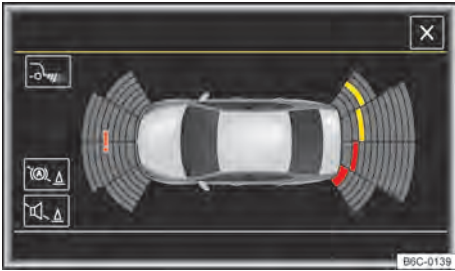

Fig. 100 Indication on the radio system: full screen mode. The detected areas depend on the vehicle version.

Depending on the model and version of the vehicle or the radio, the parking aid and the visual indication of an obstacle may not be available.

On the radio system the detected areas are represented by various segments → Fig. 100. The more the vehicle approaches an obstacle, the more the segment will also approach the illustrated vehicle. Simultaneously acoustic alarms are sounded.

- Nearby obstacle. A continuous acoustic sound is sounded. **Stop driving!**
- Obstacle in the way of the vehicle's course. An intermittent acoustic sound is sounded. The shorter the distance, the shorter the intervals between acoustic alarms.
- Obstacle out of the vehicle's course.
- 🔇 Muting the acoustic warnings.
- 🔊 Enabling and disabling the manoeuvre braking (depends on the version).
- 📷 Switching to the rear view camera system (version dependent).
- !! System with malfunction in the surveyed area (version dependent).

Troubleshooting

Sensor without visibility, malfunction warning, the system turns off

In case of damage to a sensor, the detection range of the sensor is permanently turned off.

In case of malfunction of the parking aid, a continuous acoustic warning is emitted for approximately 3 seconds when it is turned on for the

first time or depending on the vehicle version, by means of a text message with an audible alert and by the flashing of the control light on the  button. When the sensors are dirty or covered, the corresponding group of sensors is displayed on the Park Distance Control display exhibition. Furthermore a cleaning indication is displayed (version dependent).

- Clean the sensors or remove stickers or accessories from the sensors and from the rear view camera system → page 255.
- Check for damages.

The system behaves different from expected

Several causes are possible:

- The sensors are dirty → page 255. Apart from dirt and snow, the visibility of the sensor may also be compromised by cleaning products residues or linings.
- The system's prerequisites must be satisfied → page 123.
- The sensors are covered with water.
- The vehicle is damaged in the area of the sensors, for example by parking bumps.
- The sensors' viewing areas are obstructed by accessories such as bike support systems.
- Modifications to the paint in the vicinity of the sensors or constructive modifications have been made, for example, to the front or chassis of the vehicle.
- Noise sources, such as rough asphalt or cobblestone pavements interfere with the ultrasound signal.

Possible solutions

- Turn the system off temporarily.
- Check whether one of the mentioned possible causes matches the problem.
- ◀ – After eliminating the source of the malfunction, the system can again be turned on.
- Should the system still behave in an unexpected fashion, have the system checked at a Volkswagen dealership. ▶

Rear view camera system

Introduction

The rear view camera on the rear of the vehicle facilitates the driver's rear view and assists with the parking manoeuvre.

According to the version of the vehicle, the rear view camera system may not be available.

The rear view camera displays the area behind the vehicle on the radio system display screen. According to the mode, orientation lines support the rear view.

WARNING



The use of the cameras to assess the distance to obstacles (people, vehicles, etc.) is imprecise and may cause serious accidents and injuries.

- The camera lenses amplify and distort the field of vision making the displayed objects seem altered or imprecise.

Enabling and disabling

Please refer to  at the start of the chapter on page 125.

Enabling the rear view camera system

- Selecting reverse gear.
- **OR:** on the centre console press the  button
- **OR** on the radio display touch the  button.

Disabling the rear view camera system

Drive forward at least 15 km/h.

Representation on the display

Please refer to  at the start of the chapter on page 125.







The image of the rear view camera system is displayed on the radio system.

The functions and representations depend on the version and may differ.

Settings

With the rear view camera system enabled, settings may be configured by means of the function touch pads. Some settings depend on the version.

Function touch pad surfaces and rear view camera system icons:

-  Exit current display.
-  Adjust the display: brightness, contrast, colour.
-  Switch to Park Distance Control → page 122.
-  Displays the Park Distance Control indicator,
-  Hides the Park Distance Control indicator,
-  Turning the Park Distance Control sound on and off.

Orientation lines

Red line: safe distance backwards

Green side-lines: vehicle extensions.

Assumptions

Please refer to  at the start of the chapter on page 125.

To recognize a parking lot, the following assumptions must be satisfied:

- Not exceed **15 km/h**.
- Parking space width: **vehicle length + 0.2 m**.

For the display of a faultless image the following prerequisites must be satisfied:

- Closed boot lid.
- The surroundings correspond to a flat surface.
- The vehicle is not loaded in the back.

Parking

📖 Please refer to ⚠ at the start of the chapter on page 125.

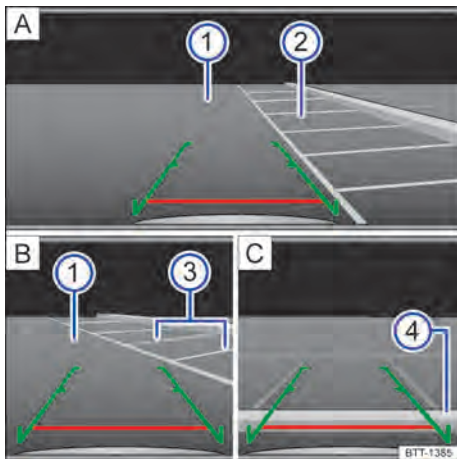

Fig. 101 Exhibition on the radio system display: parking with the rear view camera system.

Key for → Fig. 101:

- A** Select parking spot.
- B** Parking in the selected parking spot.
- C** Line up vehicle to parking spot.
- 1** Lane.
- 2** Parking space.
- 3** Side limits of the parking space.
- 4** Rear limit of the parking space.

Entering the parking space

- Position the vehicle in front of the parking spot → Fig. 101 **2** **A**.
- Selecting reverse gear.
- Drive slowly in reverse and manoeuvre so that the green side guides lead in between the delimiting lines of the selected parking space **2** **A**.
- Align the vehicle in the selected parking spot so that the green side guidelines are superimposed on the lateral limitation lines **3** **B**.
- Stop the vehicle when the red line hits the rear limit **4** **C**.

Troubleshooting

📖 Please refer to ⚠ at the start of the chapter on page 125.

No camera image, malfunction warning, the system turns off

- Clean the camera lens or remove the stickers or accessories from the camera → page 255.
- Check for damages.

The system behaves different from expected

Several causes are possible:

- The camera is dirty → page 255. Apart from dirt and snow, the camera view may also be compromised by cleaning products residues or coatings.
- The system's prerequisites must be satisfied → page 125.
- The camera lens is covered by water.
- The vehicle is damaged in the area of the camera, for example by parking bumping.
- The camera's viewing areas are obstructed by accessories such as bike support systems.
- Modifications to the paint in the vicinity of the camera or constructive modifications have been made, for example, to the front or chassis of the vehicle.

Solution for all cases

- Turn the system off temporarily.
- Check whether one of the mentioned possible causes matches the problem.
- After eliminating the source of the malfunction, the system can again be turned on.
- Should the system still behave in an unexpected fashion, have the system checked at a Volkswagen dealership.

Brake support systems

Information to the brake support systems

The vehicle is equipped with a brake support system:

- ESC system: the ESC, EDS, TCS, BAS, ABS and EBV brake support systems only function when the engine is running. They make a considerable contribution to active driving safety.

When the brake supporting systems are in operation, the brake pedal may pulse or noises may occur. Keep the necessary pressure constantly on the brake pedal.

Traction control (TCS)

The TCS reduces the engine drive in case of wheel skidding and adjusts the drive to road surface conditions. The TCS facilitates the starter, acceleration, and uphill effort, even under adverse road surface conditions.

When the traction control system is active the  indicator lamp will flash on the instrument cluster display.

Electronic Stability Control (ESC)

The ESC helps reduce the risk of skidding and improve driving stability under given driving conditions → .

In reverse gear, the ESC system may limit speed to ensure vehicle stability.

When the ESC is controlling, the  indicator lamp will flash on the instrument cluster display.

In ESC, the ABS, BAS, TCS and the EDS are integrated. The ESC must always be enabled. The ASR may be disabled through the radio system should sufficient propulsion no longer be reached under some driving scenarios → page 129. Next, re-enable the TCS → page 129.

Anti-lock brake system (ABS)

The ABS prevents the wheels from locking when the brakes are applied up until the point where the vehicle is nearly stationary and assists the driver in steering the vehicle and keeping it under control. This means that the vehicle is also less likely to spin, even when the brakes are depressed fully:

- Strongly press and hold the brake pedal. Do not take your foot off the brake pedal or reduce the force on the brake pedal!
- Do not “pump” the brake pedal or reduce the pressure on the brake pedal!
- Steer the vehicle while the brake pedal is fully depressed.
- The ABS will switch off when the brake pedal is released or if the pressure on the brake pedal is reduced.

If the ABS is taking corrective action, you will be aware of a **pulsing movement in the brake pedal** and some noise. However, ABS will not necessarily guarantee shorter braking distances in *all* conditions. The braking distance could even be longer when braking on gravel or on fresh snow covering an icy or slippery surface.

Electronic brake variator (EBV)

In all vehicles, upon activating the brakes, the vehicle's centre of gravity shifts forward. This generates the risk of blocking rear wheels due to low traction. The electronic braking distribution limits the brake force on the rear wheels, ensuring an adequate brake force distribution between the front and rear axles. The electronic brake variator is part of the ABS functions.

Brake assist (BAS)

The BAS may assist in reducing the braking distance. The brake assist system enhances braking power when the driver suddenly hits the brake pedal in emergency braking situations.

Do not reduce the the pressure on the pedal when the BAS is actuating. Upon reducing the pressure on the brake pedal the BAS stops its brake enhancing action.

Electronic Differential Lock (EDL and XDS)

The EDL brakes the wheel that is skidding and transfers the traction force to the other traction wheel.

The EDL turns off automatically under extraordinary strong demand to prevent the brake disc from overheating. The EDL is automatically activated again as soon as the brake has cooled down.

The XDS is an extension of the electronic differential lock. The XDS does not react to the skidding of the wheels, but to the relief of the inside front wheel when in fast curve driving. The XDS exerts pressure on the brake of the curve inside ▶

wheel, to prevent skidding. This way traction is improved. This helps the vehicle to keep within the desired lane.

Automatic Post-Collision Braking System

In case of an accident the Automatic Post-Collision Braking System may assist the driver in reducing the risk of skidding and the risk of further collisions during the accident by way of and automatically initiated braking.

The Automatic Post -Collision Braking System only works with frontal, side and rear collisions when the airbag control unit detects a given threshold for its activation during the accident.

The braking of the vehicle occurs automatically by way of the ESC, as long as the brake's hydraulics, the ESC and the electric system are not damaged and remain operational.

The following activities override the automatic braking in an accident:

- If the driver steps on the accelerator pedal. No automatic braking will occur.
- When the pressure exerted by stepping on the brake pedal exceeds the pressure on the brake induced by the system. The vehicle is manually braked.

WARNING

The intelligent technology shipped with the braking support systems cannot go beyond the limits imposed by physics and will only operate within the limitations of the system. Driving fast on icy, slippery or wet roads can lead to a loss of control of the vehicle and could cause serious injury to the driver and its passengers.

- Adapt your speed and driving style to according to the visibility, weather, road and traffic conditions. Do not let the extra safety afforded by the ABS, BAS, EDL, TCS and ESC braking support systems lead you into temptation of putting safety at risk when driving.
- Slippery and wet roads remain rather dangerous, even with the ESC and all the other systems.
- Driving at high speeds on wet roads can cause the wheels to lose contact with the road surface and "aquaplane". A vehicle cannot be braked, steered or controlled once it has lost contact with the road surface.

- The brake support system cannot prevent an accident if, for example, you are driving too close to the vehicle in front or are driving too fast for the respective driving situation.
- Despite the braking support systems being very effective and able to help control the vehicle in difficult driving situations, please always remember that the driving stability of the vehicle depends on tyre grip.
- When accelerating on a slippery surface, for example on ice and snow, press the accelerator carefully. Even with the braking support systems the wheels may skid. That may cause the loss of control over the vehicle.

WARNING

The effectiveness of the ESC can be considerably reduced when other components and systems that affect the dynamics of driving are not correctly serviced or are not functioning properly. This also applies, but not exclusively, to the brakes, tyres and other systems that have already been named.

- Always remember that modifications and changes to the vehicle may affect the correct functioning of the ABS, BAS, TCS, EDS and ESC systems.
- Alterations to the suspension or the use of factory unauthorized wheel and tyre sets may have a detrimental effect on the working of the ABS, BAS, TCS, EDS and ESC reducing their efficiency.
- ESC efficiency is also conditioned to the use of suitable tyres → page 233, *Important information on wheels and tyres.*

WARNING

Driving without the brake servo can considerably increase the braking distance and thus cause accidents and serious injuries.

- Never allow the vehicle to roll if the engine is switched off.
- If the brake servo is not functioning or the vehicle is being towed, the brake pedal will have to be depressed more forcefully, since the braking distance will be increased due to the lack of braking force support.



Operating noises may be heard during regulating procedures of the described systems. <

TCS Enabling and disabling

Should not sufficient propulsion be reached, you may disable the TCS (for vehicles with ESC):



- When driving on loose ground or deep snow.
- During “free wheel spinning” while stuck in mud or other areas.

Then, enable the TCS function again.

Enabling and disabling the TCS

- According to the version of the vehicle and of the radio, press the **CAR** button on the radio system → page 28.
- Open the menu **Vehicle settings** on the radio system.
- Touch the **ESC system:** function button.
- *Turning the TCS off:* select the **TCS deactivated** option.
- *Turning the TCS on:* select the **TCS activated** option.





OR

- Depending on the vehicle and radio version, on the radio display, touch the settings button  **OR** the  button to enable and disable the function.
- Touch the **Car** function button.
- Touch the **Stability control (ESC)** function button.
- *Turning the TCS off:* select the **TCS deactivated** option.
- *Turning the TCS on:* select the **TCS activated** option.

With the TCS disabled, the yellow  warning lamp will flash on the instrument cluster display. <

Troubleshooting

Failure warning and indicator lamps

-  **Stop driving!** Damaged brake system. Seek out assistance from a Volkswagen Dealership immediately → .
-  **Lit:** ABS out of action or malfunctioning. Contact a Volkswagen Dealership. The vehicle can be braked without ABS.
-  **Lit:** ESC disabled for system-related reasons. Switch the ignition off and on again. As the case may be, drive on for a short distance at about 15-20 km/h. If  remains on, seek out a Volkswagen Dealership.

Guidelines for the braking support systems

When there is a suspicion that there may be a faulty function, read and observe the following instructions:

- The ESC and TCS can only function properly when all four wheels are equipped with the same tyre type and model. Different diameters among the wheels/tyres may cause an unexpected reduction in engine power.
- In case of damages in the ABS system, the ESC, TCS, and EDS will also be disabled.
- Operating noises may result from adjustments to the described systems.



Adverse conditions:

The electronic stability program (ESC) may not identify very steep slopes (over 30%). This circumstance may affect the regular operation of the electronic stability program (ESC) and consequently the hill assist system (HHC - Hill Hold Control), emergency braking assistant (Front Assist) and parking sensor.

To restore the aforementioned systems, it is sufficient that the vehicle is turned off and on again and that the driver starts the car and drives it at a speed greater than 25 km/h for a few seconds.

WARNING

Driving with faulty brakes may cause severe accidents and injuries.

- If the braking system warning lamp  lights up along with the ABS control lamp , the ABS function may be faulty. Because of this it may be possible that the rear wheels block relatively quickly when braking. Locking rear wheels may cause the driver to lose control >

over the vehicle! If possible, reduce speed and drive carefully at minimum speed to the nearest Volkswagen Dealership to check the braking system. Avoid sudden braking and driving manoeuvres while driving.

- If the ABS control lamp  lights up or remains lit while driving, the ABS is not functioning properly. The vehicle can only be braked with regular brakes (without ABS). The protection provided by the ABS will not be available under this scenario. Go to a Volkswagen Dealership as soon as possible.

Practical equipment

Stowage compartment

Introduction

Only use stowage compartments to stow light or small objects.

WARNING

Loose objects may be flung through the vehicle interior in the event of a sudden driving or braking manoeuvre. This can cause serious injury and can also lead to loss of control of the vehicle.

- Do not stow any pets or any hard, heavy or sharp objects in the vehicle's open stowage compartments, on the dash panel, on the shelf behind the rear seats, or in items of clothing and bags in the vehicle interior.
- Always keep the stowage compartment cover closed while driving.

WARNING

Items in the driver footwell can hinder pedal operation. This can lead to loss of control of the vehicle and increase the risk of serious injury.

- Ensure that all pedals can always be operated without any hindrance.
- Foot mats must always be properly secured in the footwell.
- Additional foot mats or other floor coverings should never be placed over the fitted foot mat.
- Ensure that no objects can enter the driver footwell while the vehicle is in motion.

NOTICE

- Hard objects on the shelf can chafe against the wires of the heating element in the rear window and cause damages.
- Do not store any temperature-sensitive objects, food or medicines inside the vehicle. Hot and cold temperatures could damage them or render them unusable.

- Items stored in the vehicle made from transparent materials, e.g. glasses, magnifying glasses or transparent suction cups on the windows, can concentrate the sun's rays and thus cause damage to the vehicle.

i The ventilation openings between the rear window and the luggage compartment cover must not be covered as this would prevent stale air escaping from the vehicle.

Stowage area in the lower part of the centre console

📖 Please refer to **▲** and **⌚** at the start of the chapter on page 130.



Fig. 102 In the lower part of the centre console: stowage area.

On the bottom of the centre console there is an open stowage area → **Fig. 102**.

i Depending on the vehicle version, the storage compartment may have a USB port. → page 137 and wireless charging function → page 131..

Wireless charging function

📖 Please refer to **▲** and **⌚** at the start of the chapter on page 130.

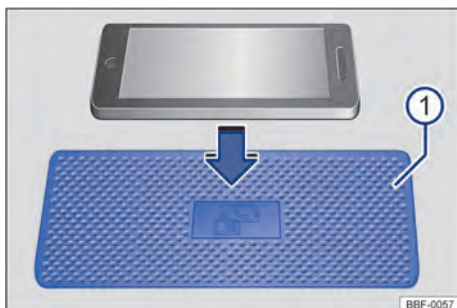

Fig. 103 Stowage compartment with pad for wireless charging function. The symbol on the lining pad may appear differently in some vehicles.

Depending on the vehicle version and country, the wireless charging function may not be available.

Depending on the vehicle version, the charging area → **Fig. 103** **①** of the wireless charging function is located in the middle of the centre console or storage compartment, in the area between the front seats.

The wireless charging function allows wireless power transferring by short-distance electromagnetic induction.

The Qi standard allows the wireless charging of smartphones to support the Qi protocol.

To find out if a mobile phone device supports the Qi standard, check the device specifications in the manufacturer's site.

Only a Qi-compatible mobile phone without a protective cap with a dimension (width x length) of approximately 80 mm x 140 mm (3.15 in x 5.512 in) can be placed evenly on the wireless charging function floor mat.

The maximum charging power is 10 watts. The power charge depends on mobile phone configurations and is controlled based on battery level and temperature.

Before charging a device, remove all foreign objects with metallic parts, such as coins, keys, and clips, from the charging area.

To charge a mobile phone that supports the Qi protocol, place it with the screen facing upwards in the centre of the charging area. The charging process begins automatically.

The factory-fitted radio system informs the beginning of the charging process and, if applicable, also informs of any foreign objects with metallic components detected in the charging area.

Remove these foreign objects to resume charging.

If a mobile phone is not placed correctly in the charging area or is too small, it may not be recognized appropriately. In these special cases, the radio system may report a foreign object detected. In this case, simply place the mobile phone closer to the centre of the charging area to obtain better results.

New technologies may not support the wireless charging function. The mobile phone manufacturer provides more information about compatibility.

Storage compartment cover

Depending on the vehicle version and country, the storage compartment for the wireless charging function has a cover for the mobile phone screen.

The cover may avoid distractions coming from the mobile phone, such as incoming messages.

The cover must always be closed while driving and the mobile phone screen must be completely covered.

⚠ WARNING

- Notifications shown on the mobile phone screen may distract the driver and increase the risk of a serious accident.
- Do not place any objects made of metal or containing metallic components on the charging area. Metallic objects may become extremely hot. This can cause skin burns and even fire hazards, in more extreme cases.
- Do not place identification cards (e.g. credit cards, bank cards) with magnetic strips or chips in the charging area. In extremely rare cases, the data stored in the magnetic strip or chip may become useless.

ⓘ NOTICE

- Charging is only activated when while the ignition is on.

- Always use mobile phones compatible with the Qi protocol in the charging area.
- Charging performance is optimal when the mobile phone is placed on the centre of the charging area.
- Thick mobile phone protective cases (greater than 2 mm) may affect charging performance.
- Some people can hear faint clicks during charging. That is perfectly normal and does not indicate anything is wrong.
- If the vehicle's interior temperature is too high (e.g. after prolonged exposure to sunlight), wait until the temperature drops before using the wireless charging function.
- The mobile phone heats up more during wireless charging compared to conventional corded charging. That is normal.
- Depending on the battery level and temperature, some mobile phones may stop charging at around 80%. That is also normal.

Front passenger side glove compartment

📖 Please refer to ⚠ and ⓘ at the start of the chapter on page 130.

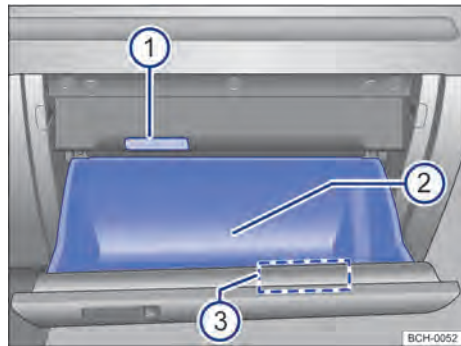

Fig. 104 On the front passenger side: open glove compartment.

The scope of items in the glove compartment depends on the vehicle version. ▶

Key for Fig. 104:

- ① Internal glove compartment lighting.
- ② Vehicle wallet holder.
- ③ Coin holder.

Opening and closing the stowage compartment

To *open*, pull the handle.

To *close*, press the lid fully upwards.

Vehicle wallet

The glove compartment is intended to accommodate the vehicle wallet. The vehicle wallet must always be kept in this stowage compartment.

⚠ WARNING

An open stowage compartment may increase the risk of severe injuries in case of an accident or a sudden driving or braking manoeuvre.

- Always keep glove box closed while driving.

Front centre armrest stowage compartment

📖 Please refer to ⚠ and ⌚ at the start of the chapter on page 130.



Fig. 105 In the front centre armrest: stowage compartment.

Depending on the vehicle version, the centre armrest may not be available.

Open: lift the centre armrest → Fig. 105.

Close: swing the centre armrest down.

⚠ WARNING

The centre armrest may restrict the movement of the driver's arms and lead to severe accidents and injuries.

- Always keep the centre armrest stowage area closed while driving.

⚠ WARNING

Never ever transport a person or a child on the centre armrest.

📍 Depending on the vehicle version, there may be a USB port in the rear part of the armrest ↔ → page 137. <

Storage compartment in the roof console (glasses compartment)

📖 Please refer to ⚠ and ⌚ at the start of the chapter on page 130. <



Fig. 106 In the roof console: glasses compartment.

Open: press and release the → Fig. 106 button.

Close: press the lid upwards until it engages.

📍 To ensure proper interior monitoring of the vehicle, the stowage areas must be closed when locking the vehicle → page 64. <

Other stowage compartments

📖 Please refer to ⚠️ and ⚠️ at the start of the chapter on page 130.

Other possible compartments:

- In the front and rear door lining.
- Stowage bags on the front seats back rests.
- Surface behind the rear seat for small clothes.
- According to the vehicles version, there may be a card holder in the lower centre console.
- **Hooks for clothes** on the centre door columns.
- **Bag hook** in the luggage compartment → page 181.

⚠️ WARNING

Objects that are not secured or are secured incorrectly behind the rear seat backrest can cause serious injuries in the event of a sudden driving or braking manoeuvre or accident.

- Do not stow any hard, heavy or sharp objects in pockets, purses or loose on the surface of the luggage compartment cover.
- Never carry animals on top of the luggage compartment cover.

⚠️ WARNING

Hanged clothing may compromise driver visibility and, therefore, cause severe accidents and injuries.

- Ensure that clothes hanged on the clothing hook are not compromising driver visibility.
- Use the vehicle clothing hook only to hang small clothes. Never leave hard, heavy or sharp objects in pockets.

⚠️ NOTICE

Each bag hook supports a maximum load of 2.5 kg.

Cup holder

📖 Introduction

Bottle holders

Bottle holders are located in the open stowage compartments of the driver and front passenger doors.

⚠️ WARNING

Incorrect use of the cup holders can cause injury.

- Do not place any hot drinks in a cup holder. In the event of a sudden braking manoeuvre or accident, hot drinks in a cup holder can be spilled and cause scalding.
- Ensure that drink bottles or any other objects do not enter the driver footwell and obstruct the pedals while the vehicle is in motion.
- Never place heavy cups, food or any other heavy items in the cup holder. These heavy objects could be flung through the vehicle interior during an accident and cause serious injuries.

⚠️ WARNING

Closed drink bottles can explode in the vehicle in extreme heat or crack in extremely cold temperatures.

- Never leave closed drink bottles in an extremely hot or extremely cold vehicle for extended periods.

⚠️ NOTICE

Do not leave any open drinks in the cup holder while the vehicle is in motion. Drinks that are spilled, for example during braking, can damage the vehicle and the vehicle electric system.

Cup holders in the centre console

📖 Please refer to ⚠ and ⌚ at the start of the chapter on page 134.

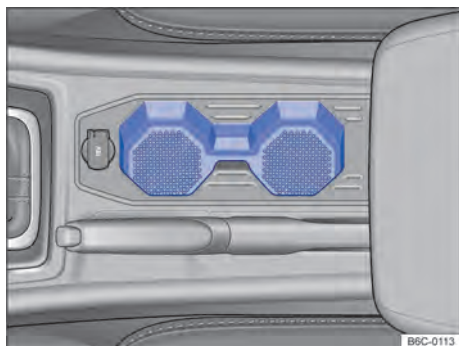

Fig. 107 In the front centre console: cup holder.

There are two cup holders in the front centre console → Fig. 107.

Ashtray and cigarette lighter

📖 Introduction

⚠ WARNING

Improper use of the ashtray and cigarette lighter could cause fires, burns and other serious injuries.

- Never place paper or any other items in the ashtray that could start a fire.
- The single purpose of the ashtray is to store used cigarettes, as well as the substances generated by them, such as ashes.

Removable ashtray in the cup holder

📖 Please refer to ⚠ at the start of the chapter on page 135.



Fig. 108 Removable ashtray.

- ◀ To use, put the ashtray in one of the cup holders on the front centre console → page 134.

Opening and closing the ashtray

To *open*, lift the cover → Fig. 108.

To *close*, press the ashtray cover down.

Emptying the ashtray

- Lift the ashtray up to remove it from the drink holder.
- Open the ashtray and empty the cold ash into an appropriate container.
- Once it has been emptied, place the ashtray back into the drink holder and press down. ▶

Cigarette lighter

- ◀ 📖 Please refer to ⚠ at the start of the chapter on page 135.



Fig. 109 On the front centre console: cigarette lighter. ▶

According to the vehicle version, the cigarette lighter may not be available.

- With the ignition switched on, press the cigarette lighter knob → Fig. 109 inward.
- After a few seconds, the cigarette lighter knob will automatically move back up.
- Pull out the cigarette lighter and light the tobacco product on the glowing spiral → ⚠.
- Place the cigarette lighter back into its compartment.

⚠ WARNING

Improper use of the cigarette lighter could cause fires, burns and other serious injuries.

- Always use the cigarette lighter properly. Use it only to light cigarettes.
- Never leave children in the vehicle unattended. The cigarette lighter can only be used when the ignition is switched on.

 The cigarette lighter compartment can also be used as a 12 V socket → page 136, *Socket*.

Socket

Introduction

Electrical devices may be connected to the socket in the vehicle.

The electric devices must be in perfect condition for use. Do not use faulty devices.

The 12-volt socket only works while the ignition is switched on.

⚠ WARNING

Improper use of the socket and electrical devices can cause fires and severe injuries.

- Never leave children in the vehicle unattended. The socket and the devices connected to it can be used when the ignition is switched on.
- should the electric devices get very hot, turn them off and disconnect them from the outlet.

⚠ NOTICE

To prevent damage to the electrical system, never connect electric devices to the 12-volt outlet socket which generate electric power to charge the battery of the vehicle, such as solar panels or battery charging units.

- Only use accessories that have been approved in accordance with current directives concerning electromagnetic compatibility.
- To prevent damage from electric current fluctuation, the electric devices must be turned off prior to switching the ignition on or off. Given the version of the vehicle, if the Start-Stop system automatically turns the engine off and on again, the electric equipment does not need to be turned off.
- Never connect electric devices to the 12 V power outlet which consume more power than the indicated power. When exceeding the indicated power, the vehicle's electrical system may be damaged.
- Refer to the owner's manuals of the connected devices!

 Do not leave the engine running when the vehicle is stationary.

 The ignition turned on plus use of electric appliances while the engine is switched off drains the battery.

 Unshielded devices may damage the radio system and electronic components of the vehicle.

12 V Socket in the vehicle

 Please refer to ⚠ and ⚠ at the start of the chapter on page 136.



Fig. 110 In the front centre console: 12 V socket. ▶

Maximum power rating

12 V socket 120 W

The maximum power rating of the sockets may not be exceeded. The maximum power rating of each device is stated on its type plate.

Radios

Before using the unit for the first time

Depending on the vehicle version, the radio may not be available.

Control list

Before first use, following steps should be executed to safely operate the radio and make full use of its features:

- ✓ Follow safety recommendations  → page 138.
- ✓ Get yourself familiarized with the general overview of the unit.
- ✓ In **System Configurations**, reset the radio to its factory settings (factory settings / reset system → page 165 or → page 174).
- ✓ Use appropriate data storage units for media operation.

Other applicable documents

Apart from this manual for the use of this radio and its components please also see the following documents:

- Operating Manual of the mobile telephone system.
- Operating Manual of the external multimedia units.
- Instructions for a retrofitted accessory.

Convenience overview

The radio may be factory equipped with the following components, in part, as optional equipment:

- Loudspeakers, installed in different fitting locations and output levels (Watt).
- Multifunction steering wheel with its controls.
- Media units.
- Cable connections to the external multimedia units.
- Wireless connection for external multimedia devices.

- Mobile phone interface.
- Sound system.

Safety recommendations

Prior to first use of the device, read and follow the safety instructions listed below to detect and prevent possible hazards to yourself and others:

- Read this instruction with attention:
- Some function areas may contain links to third party web pages. Volkswagen is not responsible for this content and its access does not authorize copying, reproducing or quoting third-party content.
- For optimal safety of personal information stored in the radio system, it is recommended to keep the valet mode on → page 176 when possible.
- Radio stations and other means of communication, such as newspaper websites and third-party apps are responsible for the content of information transmitted in such media.
- Covered parking places, tunnels, tall buildings, mountains or additionally operated electric equipment, such as battery chargers, may also interfere with the radio reception.
- Metal-coated stickers or films may hinder reception in vehicles with window aerials.

WARNING

Accidents and injuries can occur if the driver is distracted. Operating the radio may distract drivers from the traffic.

- Never reset the system while driving.
- Always drive carefully and responsibly.
- Adjust sound volume settings to allow the driver to hear external warnings and sounds (for example: emergency service sirens)
- Excessively high volumes may compromise hearing. This also occurs when vehicle occupants' hearing is submitted to high volumes, even if briefly.

WARNING

Sudden volume variations may occur when switching or connecting an audio source.

- Reduce the master volume before connecting or switching audio sources.

WARNING

Connecting, inserting, or removing data storage units while driving may distract the driver from his/her surroundings and cause accidents.

WARNING

External device connection cables could hinder the driver's movement, depending on how they are arranged.

WARNING

Loose or unsecured external devices may be flung through the vehicle interior and cause injuries in case of sudden evasive or breaking manoeuvres or in the event of accidents.

- Never place or attach external devices on doors, windscreen, on or near areas marked with "AIRBAG" on the steering wheel, dashboard, seat backrests, or between these areas and vehicle occupant himself. External devices may cause severe injuries in the event of accidents, especially if the airbags are triggered.

WARNING

In explosion prone places, turn mobile telephones off!

WARNING

Unfavourable light conditions and a damaged or dirty display may cause information and indications not able to be read or be correctly read on the display.

- Indications or information on the display must never be a reason to run a safety risk. The display is not in condition to replace the drivers attention.

WARNING

Radio stations may broadcast important warnings. The following conditions may compromise radio signal reception:

- If your current location is in a region of poor or no reception. Such region includes tunnels, urban canyons, parking garages, underground passageways, mountains, and valleys.
- If, in areas with the bandwidths of the radio stations present interferences or are unavailable.

- When the necessary vehicle components required for radio signal reception are damaged, inoperative or without sufficient electric power.

⚠ WARNING

Operating radios with excessive volume, especially if over 85 decibels, may cause ear injuries.

- If the volume is excessively high, exterior acoustic signals, such as police and fire department sirens and other vehicles' horns, may not be audible and may cause accidents.

⚠ WARNING

- Liquids may cause damage, overheat the radio unit and lead to a greater risk of fire.
- To reduce the risk of fire or electrical discharge, do not expose the radio unit to rain or humidity. To avoid the risk of electrocution, do not open the radio unit. Seek out assistance at a Volkswagen Dealership.

ⓘ NOTICE

Use the appropriate power supply. The radio is designed for use in conjunction with a 12V negative grounded battery system. Never use this radio with other battery systems, especially a 24V battery system.

ⓘ NOTICE

If the radio is out of service (no power, no sound) or in other abnormal conditions (foreign objects, exposed to water, smoke or unusual smell), turn it off immediately and seek out assistance at a Volkswagen Dealership.

ⓘ NOTICE

Mobile phones must always be turned off in locations in which their use is prohibited. The radiation generated by mobile phones may cause interference with sensitive medical devices and technical equipment, which may hinder or damage such devices.

ⓘ NOTICE

The vehicle's loudspeakers may be damaged if the volume is too high or the sound is distorted.

ⓘ NOTICE

Introduction of objects, incorrect placing and introduction of data storage units of different shapes and sizes may damage the media readers and the radio.

- Ensure correct insertion position when inserting a data storage unit.
- Insert only adequate data storage units into the respective media reading units.
- Excessive pressure could break the SD card slot lock.

ⓘ NOTICE

Foreign matter and liquids adhering to a data storage device may damage the media reading unit and the radio.

- Do not attach stickers or similar materials to data storage units. Stickers may peel off and damage the media reading unit.
- Do not use CDs with printable data. Residues and stickers may peel off and damage the media reading unit.

Instructions for use

- When using the radio, follow the specific national recommendations and legal determinations.
- To operate the radio a light touch on the button or screen suffices.
- To make the best of the radio's features and optimal operation it is important that the date and time be correctly set.
- Some of the function surfaces and modes detailed herein may not be available in country-specific software. The absence of a radio icon or function button on the display is not a device defect.
- Depending on the country, some functions of the radio are no longer selectable on the display as of a certain speed threshold, as required by local law.
- In some countries, there may be restrictions regarding the use of Bluetooth^{®1)} devices and Wi-Fi connections. Additional information and Wi-Fi connections may be obtained from local authorities.

¹⁾ Bluetooth[®] is a registered trademark of Bluetooth[®] SIG, Inc.

- The display of all indications and the execution of the functions are only available after the complete start up of the radio. The start up time of the system depends on the scope of the radio function and can last more than usual especially at low and high temperatures.
- After a disconnection of the vehicle battery, turn the ignition on before switching on the radio.
- The radio is connected to the vehicle – the radio cannot be installed in another vehicle.
- In order not to impair its operation, repairs and modifications to the radio may only be performed by a Volkswagen Dealership.
- Phone calls received in mobile phones inside the vehicle may cause interference in the vehicle's loudspeakers.
- With the engine turned off and low battery charge, the radio is automatically turned off.
- High speed, unfavourable weather and road conditions, as well as poor network connection may hinder or interrupt mobile phone calls inside the vehicle.

Display

Active display areas with recorded functions are referred to as “function buttons” and operated by brief *touches* or extended *touches* on the display. Function buttons are described herein by the word “function button”.

Clean the display

To clean, turn the radio off.

To clean the display, use a smooth and clean cloth slightly damp with clean water.

Soften resistant dirt with a humidified cloth, taking care not to damage the radio.

! NOTICE

Do not dry clean the display. Doing so may cause scratches that cannot be removed.

- Do not use aggressive or solvent-based cleaning products. Such cleaning products may damage the radio and leave the display “misty”.
- Exert only a light pressure when cleaning the display.

Power management

When, with the ignition turned off and the device on, the battery power falls below the minimum voltage, an acoustic signal sounds and the message **LOW BATTERY** is displayed. In this case, the unit must be switched off.

Anti-theft coding

The unit is protected against theft and unauthorized use by a security code (anti-theft coding).

After its first being entered, the anti theft code is saved to the memory of the vehicle (convenience coding of the radio) If the anti-theft coding has to be manually deactivated, e.g. when installing the unit in another vehicle, please contact a Volkswagen Dealership.

If the vehicle battery has been disconnected, switch the ignition on before switching the unit on.

Composition Touch (R 340G)

Device overview

Overview

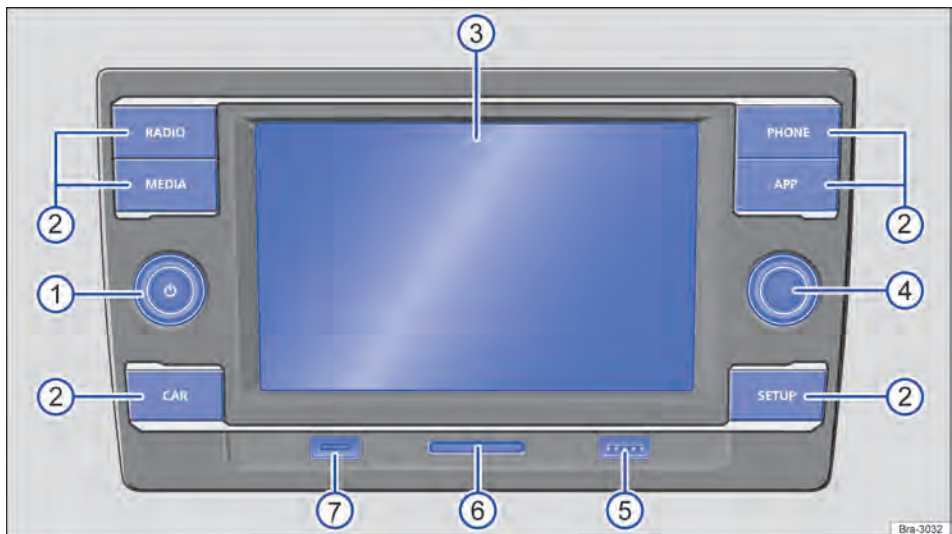



Fig. 111 Control overview.

- ① **Rotary/push knob** :
 - Press to turn the unit on or off.
 - Turn to adjust the base volume of the corresponding active source.
- ② **Radio buttons:** press to access a function button.
- ③ **Display:** touchscreen.
- ④ **Settings button:** the function is conditioned to the respective operating condition.
- ⑤ **USB port:** to connect external data storage units.
- ⑥ **SD card slot:** to insert SD cards.
- ⑦ **Microphone:** do not obstruct the microphone and keep it always clean. 

Rotary and push knob

Rotary/push knobs

The rotary/push knob  is referred to as volume control or on/off button.

The right-hand rotary/push knob is referred to as selector.

Turning the radio manually on or off

Press the on / off button briefly .

Turn the radio on or off automatically

According to its version, the unit is automatically turned off when the engine is turned off or the ignition key is removed from the ignition lock. If the radio is manually switched on again, it will be automatically switched off after approximately 30 minutes (timeout).

Volume increase ore decrease



Once on, the radio starts to operate at the last adjusted volume level, as long as the maximum pre defined turn on volume is not surpassed. 

- Turn the volume control  (right or clockwise to turn up and left or counter clockwise to turn down)

Some volume adjustments can be preset.

Mute

When in mute mode, the active audio source is interrupted or muted. The indication can be seen on the display screen .

- Turn the volume control button  counter clockwise until audio can no longer be heard. 

Basic command information

Function surface and display controls

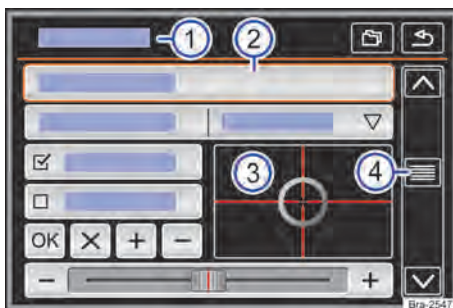

Fig. 112 Schematic representation: overview of possible function buttons on the display.

Selector button

The selector button can be turned or pushed. When *turned*, lists are searched or radio station lists or of media titles are opened. When *pressed* marked records are accessed, configurations are set and functions started or interrupted.

Radio buttons

To operate the radio buttons, press them *briefly*.

RADIO: turn on in radio mode and then change the frequency range.

MEDIA: change to media mode and from there select the media source.

CAR: to access the vehicle's and system's settings.

PHONE: access the telephone interface. If there is no telephone interface installed, the current audio source is muted.

APP: access the interface with App-Connect.

SETUP: press to show additional functions related to the current mode (radio, media, etc.). 

The device is equipped with a touchscreen → Fig. 112 .







Active display areas with recorded functions are referred to as "function buttons" and operated by brief *touches* or extended *touches* on the display. Function buttons are described herein by the word "function button" and the button symbol .

Function buttons start specific functions or open other submenus. The currently selected menu is indicated on the title line of submenus → Fig. 112 .

Inactive function buttons (grey) cannot be currently selected.

Overview of possible function buttons and displays

- 1 The title line indicates the currently selected menu and, eventually, other function buttons.
- 2 Touch to open a different menu.
- 3 Move the target over the display without removing the finger, slightly pressing **or** touching the desired position in the display to move the target to the respective position.
- 4 Gently press to move the scroll bar over the display in a single move, and scroll through the lists → page 143, *Access list entries and search lists*. 

-  Touch to gradually close some lists one level above.
-  Touch to gradually close submenus until returning to the main menu or to undo the previous entries.
-  Touch to open a pop-up window containing additional settings.
- / Some functions or displays are selected through a checkbox and activated or deactivated by a touch.
-  Touch to confirm an entry or selection.
-  Touch to close a pop-up window or an entry template.
-  Touch to gradually change the settings.
-  Gently move the scroll bar pointer along the bar with a finger move applying a light uninterrupted pressure on the display surface.

Access list entries and search lists

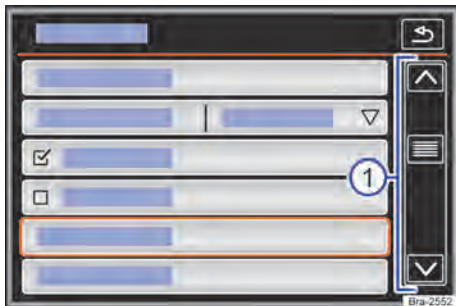

Fig. 113 Schematic representation: list entries, settings menu.

List entries can be accessed by directly touching the screen or with the selector button → Fig. 113 ①.



If the available entries on a list do not fit the display, function buttons or a scrollbar are shown on the right-hand side to scroll through entries → Fig. 113 ①.

Selecting and accessing list entries with the control button

Turn the control button to sequentially select list entries through a checkbox and search the list.

Press the control button to access the selected list entry.

Search lists (scroll)

Search by list line: Briefly touch the function button  or .

Search by list page: Briefly touch the top or bottom of the scroll bar.

Quick search by list page: Touch and hold the top or bottom of the scroll bar.

Quick search in long lists: Place finger over the scroll bar indicator and move it up or down *in a single move*. Remove the finger from the screen after reaching the desired position.

Entry masks with display keypad



Fig. 114 Representation: entry mask with display keypad.

Entry masks with display keypads are used to enter memory names or search terms in long lists, among other functions.

The function buttons listed herein are not available in all countries or topic areas.

The following chapters detail only the functions not covered in this representation.

The entry line with symbol entry mask (cursor) is located on the upper left display line. All entries are displayed in this area.

Entry masks to “enter text”

Letters, characters and special symbols can be selected in any combination to enter free texts in entry masks.

The currently displayed sequence of symbols is applied by touching the function button .

Entry masks to select stored entries

Only combinations of letters, characters and special symbols corresponding to a stored entry can be selected for the introduction mask.

If less than 99 entries can be selected, the number of remaining entries is shown through the entry line → Fig. 114 ③. Touching this function button will display all remaining entries in a list. If less than 5 entries can be selected, the list is automatically opened.

Overview of function buttons

- ① : touch to open the entry mask for special symbols and numbers. **OR:** : touch to switch to the letter entry mask.
- ② : Touch to switch to a different keypad language. The keypad language can be selected through the **System settings** menu.
- ③ : Shows the quantity and opens the list of entries corresponding to selectable presets.

Letters and numbers Touch to apply the entry line.

Letters and Press and hold to open a pop-up window with special symbols based on the letters. Select the desired characters via touch. Some special signs can also be transcribed (e.g. "AE" to "Ä").

- Touch to switch between upper case and lower case, as well as numbers and special characters.
- Touch to insert a blank space.
- Touch to apply the introduction line suggestion and close the entry mask.
- Touch to delete symbols on the entry line, from right to left. Press and hold to delete multiple symbols.
- Touch to close the entry mask.

All displays can only be shown after a complete start-up process of the radio.

Connectivity

App-Connect

Some menus and functions are not available in all the countries for all the vehicles.

The following interfaces are available in the App-Connect menu:

- Apple CarPlay™¹⁾
- Android Auto™²⁾

To prevent the driver from distraction only special applications may be used while driving →

According to the mobile device used, a connection is established through the respective interface.

Thereby it is possible that the functions and the contents displayed on the mobile devices are displayed and controlled on the radio display.

WARNING

The use of applications while driving may distract from the surrounding traffic. Accidents and injuries can occur if the driver is distracted.

- Always drive carefully and responsibly.

WARNING

Loose or unsecured mobile phones may be flung through the interior and cause injuries in case of sudden evasive or breaking manoeuvres or in the event of accidents.

- While the vehicle is in motion, always secure mobile devices properly outside the airbag deployment zones or stow them away safely.

WARNING

Inadequately or inappropriately designed applications may cause damages to the vehicle, accidents and serious injuries.

Additional displays and display options

Display indications may vary from those described herein, depending on the settings.

The time can be shown on the display status line.

¹⁾ Apple CarPlay™ is an Apple Inc. trademark.

²⁾ Android Auto™ is a Google Inc. trademark

- Volkswagen recommends to use only applications offered by Volkswagen for the specific vehicle.
- Protect the mobile device with its applications from misuse.
- Never alter the applications.
- Follow the owner's manual of the mobile device.

NOTICE

Mobile devices must always be turned off in locations where their use is not allowed. The radiation generated by mobile devices may cause interference with delicate medical and technical equipment, which may impair or damage such devices.

NOTICE

Volkswagen does not take responsibility for damages caused to the vehicle due to the use of low quality or defective applications, insufficient programming of the applications, insufficient network, for loss of data during transmission or misuse of mobile devices.

For more information, refer to the mobile device's owner's manual.

For more information, refer to the mobile device's owner's manual.

Apple CarPlay™



Fig. 116 Selection of the mobile device.



Fig. 117 Apple CarPlay™ Menu.

App-Connect main menu



Fig. 115 App-Connect main menu.

1 ⓘ: display of further information.

Open the App-Connect settings menu

In the App-Connect main menu, touch the **Config.** function button. ⓘ.

Apple CarPlay™ Requirements

The following conditions are required to use Apple CarPlay™:

- ✓ The mobile device **must** support Apple CarPlay™.
- ✓ The mobile device **must** be connected by a USB cable to the radio.
- ✓ The USB cable to be used **must** be an original cable from the mobile phone manufacturer.

Establish connection

When a mobile device is connected for the first time follow the instructions on the radio display and on the display of the mobile device.

- The assumptions for use of the Apple CarPlay™ must be met.
- Press the **APP** button.
- Select your connected mobile device pressing on the corresponding icon.

Disconnect

- While using Apple CarPlay™, touch the surface function → Fig. 117 ① to access App-Connect in the main menu.
- Touch the function button → Fig. 116 ① to end the active connection.

Particularities

During an active Apple CarPlay™ connection, the following features are enabled:

- Bluetooth connection among mobile devices and the radio are **not** possible.
- An active Bluetooth connection is automatically finalized.
- Telephone functions are only possible via Apple CarPlay™. The radio functions described in this manual are **not** available.
- The connected device **cannot** be used as a media device on the Media menu.

Voice command

Depending on the type and version of the vehicle, the voice command feature may not be available.

- On the multifunction steering wheel or on the mobile phone, press **VOICE** or **☎** **briefly** to start the device's voice command feature.
- On the multifunction steering wheel or on the mobile phone, press **VOICE** or **☎** **for a few seconds** to start the connected device's voice command feature.

 For more information, refer to the mobile device's owner's manual.

Android Auto™



Fig. 118 Selection of the mobile device.

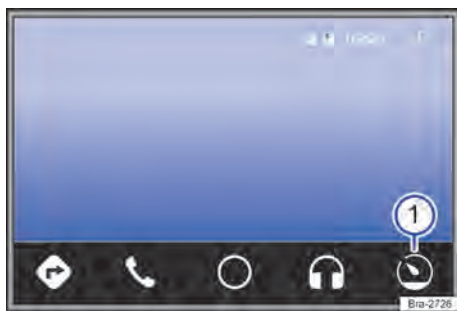



Fig. 119 Android Auto™ Menu

Android Auto™ Requirements

The following conditions must be met to use Android Auto™:



- ✓ The mobile device **must** support Android Auto™.
- ✓ The mobile device **must** be connected by a USB cable to the radio.
- ✓ The USB cable to be used **must** be an original cable from the mobile phone manufacturer.
- ✓ Depending on the mobile device used, an adequate application must be installed to use Android Auto™ on the device.

Connect

When a mobile device is connected for the first time follow the instructions on the radio display and on the display of the mobile device. 

- The assumptions for use of the Android Auto™ must be met.
- Press the **APP** button.
- Select your connected mobile device pressing on the corresponding icon.

Disconnect

- While using Android Auto™, touch the function button , → Fig. 119 .
- Select the **Return to Volkswagen** function to access the **App-Connect** main menu.



Particularities

During an active Android Auto™ connection, the following features are enabled:

- An active Android Auto™ device may be simultaneously connected to the radio via Bluetooth.
- Bluetooth connection between other mobile devices and the radio are **not** possible.
- Telephone functions are possible via Android Auto™. When the Android Auto™ device is simultaneously connected via Bluetooth to the device, the phone function can also be used.
- Simultaneous phone calls via Android Auto™ and via the radio are **not** possible.
- An active Android Auto™ device **cannot** be used as a media device on the Media menu.

Voice commands

Depending on the type and version of the vehicle, the voice command feature may not be available.

- On the multifunction steering wheel or on the mobile phone, press **VOICE** or  **briefly** to start the radio's voice command feature.
- On the multifunction steering wheel or on the mobile phone, press **VOICE** or  **for a few seconds** to start the connected device's voice command feature.

 For more information, refer to the mobile device's owner's manual.

Unit operation

Introduction

Follow the national rules and legal provisions when using the radio.

Other additional electric devices connected to the vehicle may interfere with the receipt of the broadcast radio signal and cause noises in the speakers.

 Parking lots, tunnels, tall buildings or mountains may interfere with unit signal reception.

 Metal-coated stickers or films may hinder reception in vehicles with windscreen aerals.

Radio main menu



Fig. 120 The radio main menu.

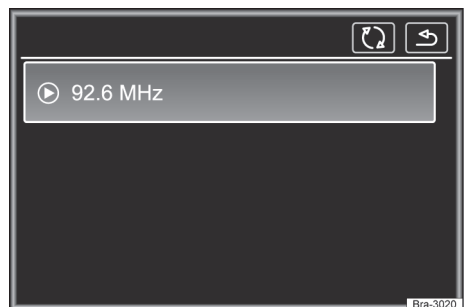

Fig. 121 Radio operation: station list.













With the radio turned on, press the **RADIO** button. Radio mode turns on.

The following options are available:

- return to the memorized radio station.
- Seek next station.
- Memorize the tuned broadcasting stations.

The currently tuned in radio station is displayed in the centre of the display. For stations with RDS the station's name can be displayed instead of its frequency, such as **RADIO 21**, in case of good reception.

Function buttons on the radio's main menu

Function button: effect	
	Radio frequency range indication.
	Select the desired frequency range.
	Opens the list of radio stations currently available → page 149.
	Opens the adjusted frequency scale (frequency range) → page 149.
	Opens the current frequency range settings menu → page 150, <i>Radio Settings</i> .
	Change between stored or available stations.
	Arrow button settings in menu → page 150, <i>Radio Settings</i> .
	Station buttons to store stations → page 148.
	Updating the frequency range's stations list → page 149.
	Function button that only becomes visible with the SCAN function is selected → page 150.
	Press the control button to start the SCAN function → Fig. 111(4).
	Canceling a function.
	Deactivation of a function.

Radio Data System RDS

RDS (Radio Data System) is a radio data system via the additional FM services whereby it is possible to display the station's names and radio texts.

RDS is not supported by all devices and may not be available everywhere and for all FM radio stations.

Without RDS basically no **additional services** are possible.

Radio text (RDS)

Some RDS enabled stations also broadcast additional text information – known as radio text.

Radio text is displayed on the upper half of the screen above the station buttons → Fig. 120 (A).

 The radio stations are responsible for the broadcast information content.

Station buttons



Fig. 122 The radio main menu.

In the main menu: *RADIO*, the currently selected frequency band stations can be stored in 15 numbered frequency tracks. These function buttons are referred to as "Station buttons".

Station button functions → Fig. 122

	Touch the station button corresponding to the desired station.
Access stations through station buttons	Stored stations can only be touched after accessing through station buttons and when available in the current location.
Change the station button group	Swipe the display in the station button area → Fig. 122, from right to left or from left to right. The station buttons are displayed in groups of 5 function button pads (1 to 5), (6 to 10), and (11 to 15).
Store stations in station buttons	See: storing stations → page 149.

Specific radio indications, menus and symbols



Fig. 123 The radio main menu.



Fig. 124 Radio operation: updatable radio station list (AM).

Function button pads and their respective meaning on the radio → Fig. 123 and → Fig. 124:

	Touch the function button or → Fig. 123.
Select the station using the arrow buttons /	Depending on the arrow button settings, the function switches between stored and available stations. Arrow button settings in the Radio settings → page 150 menu.
Select a station from the radio station list.	Touch the function button → Fig. 123 to open the list of stations. Search list and touch to select the desired station.

Function button pads and their respective meaning on the radio → Fig. 123 and → Fig. 124:

	Touch the function button → Fig. 124 to close the list of stations. If no action is made, the radio station list automatically closes after a while.
Update the radio station list	The radio station list can be manually updated with the → Fig. 124 function button.

Manually set the station frequency

Introduce the frequency range	Touch the function button → Fig. 123.
Step-by-step instructions to change the frequency	<i>Turn</i> the settings knob. OR: touch the right or left frequency range arrow buttons.
Quick scan through the frequency range	<i>Touch</i> one of the arrow buttons in the upper part of the display area → Fig. 123. The next available station is automatically selected. OR: <i>press and hold</i> one of the arrow buttons → Fig. 123 on the top of the display. After <i>releasing</i> , the next radio station available will be automatically selected. OR: press and hold the frequency range and slide to move it.

Hide the frequency range	<i>Briefly</i> press the settings knob. When a station is selected through the station button, the manual frequency selection is also closed. If no action is made, the frequency range automatically closes after a while.
--------------------------	---

Store stations

Store the current station into a station button	<i>Press and hold</i> the desired station button → Fig. 123 until an audible warning is heard. The currently played station will be stored in this station button.
Storing stations from the station list in	Touch the function button → Fig. 123 or <i>turn</i> the settings knob to open the list of stations.

Store stations

Stations already stored to station buttons are identified in the station list by the ☆ symbol.

Press and hold the display to select the desired station.

Touch the desired station button in which the station must be stored.

An audible warning is heard and the station is stored in the station button. Repeat this procedure to store other stations from the station list.

Delete stored stations

All stations stored in the **Radio Settings** menu can be deleted individually or all at once → page 150.

SCAN



Fig. 125 Radio mode: ongoing SCAN.

By selecting the SCAN function, all stations available are played for approximately 5 seconds.

SCAN will be displayed on the screen.

Starting and stopping the scan function

Starting the scan function

Briefly press the settings knob.
OR: touch the surface function  and select **SCAN**.

Touch the **SCAN** function button to stop the scanning.

The automatic scan function is also interrupted whenever a station is manually selected by the station buttons.



Radio Settings

- Select the desired frequency range.
- Touch on **RADIO**, to toggle frequency ranges.
- Touch  to open the desired settings.

Function button: effect

Scan: automatic SCAN. By selecting the SCAN function, all stations available in the current frequency range are played for approximately 5 seconds → page 150.

Sound: sound settings → page 166.

Arrow buttons: select settings for the arrow buttons  and . Settings are applied to all frequency ranges (FM).

Memory: the arrow buttons are used to change **all stations stored** in the selected frequency range.

Search station: the arrow buttons are used to change **all tuneable stations** in the selected frequency range.

Delete memory: deletes all or some stations stored.

 **All:** all stored stations are deleted.

Media mode

Introduction

“Media sources” are referred to as audio sources that contain audio data in different data storage units, such as external MP3 Players or audio files. These audio files may only be played by the respective units or audio inputs of the radio system (USB port, Bluetooth® interface, SD card or AUX-IN multimedia port).

Copyrights

Audio and video files stored in data media may be subject to applicable national and international copyright and data protection laws. Legal provisions must be followed.

 This product is protected by copyrights of Microsoft Corporation. This technology may not be reproduced or marketed without prior authorization from Microsoft or one of its authorized affiliates.



Volkswagen takes no responsibility for damaged or lost files.

Limitations and recommendations regarding data carriers

Dirt, high temperatures and mechanical damage may render a data carrier useless. Pay attention to the data carrier manufacturers instructions.

The difference in data carrier quality from different manufacturers may cause playback interferences.

The configuration of a data carrier or the devices and programs used to record the data may result in some titles or data carriers being unreadable. Information on the best ways to create audio files and data carriers (rate of compression, ID3-tag etc.) can be found, for example, on the Internet.

Due to the size, use (number of copies and deletions), of the structure of the folders and file type of the used data carrier the reading time may vary substantially.

A **playlist** only defines a certain playback sequence. Files are **not** memorized on the playlists. The playlists are **not** played back when the files on the data carrier are **not** saved where the playlist is looking for them (path related data).

Data base and file prerequisites

Only 32 mm x 24 mm x 2,1 mm (1,26 x 0,94 x 0,083 inch) or 1,4 mm (0,055 inch) SD cards can be used on the radio.

Media source	Playing requirements
--------------	----------------------

◀ SD and MMC cards of up to a max. of 2 GB (Gigabytes) with FAT16, FAT32 and exFAT file systems.

SDHC cards of up to a max. of 64 GB with FAT16, FAT32 and exFAT file systems.

SDXC cards of up to a max. of 256 GB with FAT16, FAT32 and exFAT file systems.

USB data storage unit according to USB 1.X, 2.0, 3.0 specification and FAT16, FAT32 and exFAT file systems.

iPods™, iPads™ and iPhones™ of different generations^{a)} (Only with Apple Dock or Lightning connector).

External audio source playback via the USB port.

Ⓢ Audio file reproduction via Bluetooth®.

External audio source playback through the AUX-IN port.

– MP3 files (.mp3) with 32 to 320 kbit/s or variable bit rates.

– WMA files (.wma) up to 9.2 mono/stereo without copy protection.

– M3U, PLS, ASX and WPL format playlists.

– Playlists with no more than 20 kB and 1000 records.

– File names and paths of up to a max. of 256 characters.

– External data storage unit in the USB → page 155.

– External Media Player must support Bluetooth® A2DP profile → page 158.

– 3.5 mm jack plug for audio output → page 156.

^{a)} iPod™, iPad™ and iPhone™ are trademarks of Apple Inc.



Do not use any SD card adapter.



An SD card with navigation data cannot be used as storage for other files, the saved files are not recognized by the radio.



Volkswagen may not be held liable for damaged or lost files in data media. ▶

Audio data storage unit playback sequence

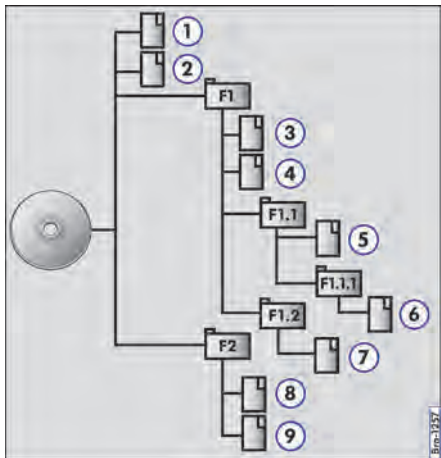

Fig. 126 Possible structure of a data storage unit.

In data storage units, audio files are often organized into data folders and playlists in order to define a certain playback sequence.

Tracks, folders, and playlists are classified numerically and alphabetically according to the name of the data storage unit.

The figure → Fig. 126 shows a typical data storage unit containing tracks, folders and sub-folders.

Thus, the tracks and folders of this data storage unit are played and displayed in the following order¹⁾:

1. Tracks ① and ② in the Root directory of the CD
2. Tracks ③ and ④ in the **first** folder **F1** of the root directory (display: □01).
3. Track ⑤ in the **first** subfolder **F1.1** of folder **F1** (display: □02).
4. Track ⑥ in the **first** subfolder **F1.1.1** of subfolder **F1.1** (display: □03).
5. Track ⑦ in the **second** subfolder **F1.2** of folder **F1** (display: □04).
6. Tracks ⑧ and ⑨ in the **second** folder **F2** (display: □05).

i The playback sequence can be modified by selecting different playback modes → page 153.

i Playlists are **not** played automatically, but must rather be individually selected in the track selection menu → page 154. ◀

Media main menu

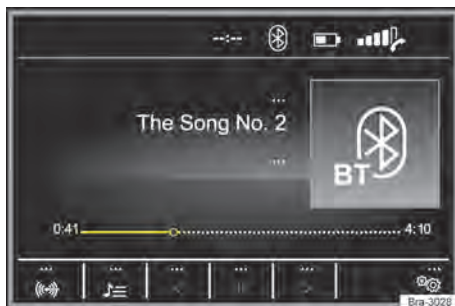

Fig. 127 Media main menu.

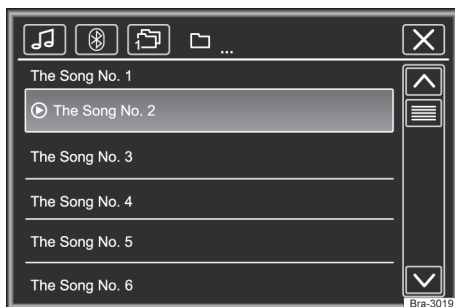

Fig. 128 Radio operation: station list.

In the main menu: Different media sources can be selected and played through **MEDIA**.

– Press the **MEDIA** button to open the **MEDIA** main menu → Fig. 127.

The last media source played is resumed.

Currently played media source is shown in the lower left function button pad → Fig. 127.

The **MEDIA** main menu shows a message if no media source can be selected. ▶

¹⁾ In the **Media settings** menu, the function **Mix/Repeat, including subfolder** must be enabled → page 154.

Media main menu function button pads

Caption for → Fig. 127 and → Fig. 128:

Songs, files and playlists can also be ticked off turning the menu button and accessed or opened pressing the button.

Shows the currently selected media source. Touch to select a different media source → page 153.

 SD Card): memory card → page 154.

 USB): external data storage unit in the USB port → page 155.



 BT Audio): Bluetooth® audio → page 156.

 AUX): external audio source connected to the AUX-IN multimedia port, depends on the vehicle's version → page 156.

 Shows the playback list → page 154.

 /  Changes tracks in media mode → page 153.

 Playback is interrupted. The function button  changes to  → page 153.



 Playback is resumed. The function button  changes to  → page 153.



 Open the **Media settings** menu → page 154.



Touch to switch between available modes.

: repeat current tracks.

: repeat all tracks.

 All tracks in the same memory level as the current track will be repeated. In the **Media settings**  menu, **Mix/Repeat including subfolder** enabled, subfolders are also included → page 154.

Mix function. The function button  changes to .

 All tracks in the same memory level as the current track will be included. In the **Media settings**  menu, **Mix/Repeat including subfolder** enabled, subfolders are also included → page 154.

Change media source

- On the **MEDIA** main menu, press the radio's  button again, to go over all the available media sources.

In the pop-up window there are currently no selectable media sources shown as inactive (grey a).

The media source currently in use is displayed on the screen.

If no media source can be selected, such is indicated on the **MEDIA** main menu.

If a media source previously played back is selected again, the playback starts at the point where it was last interrupted.











 The track information display can be disabled in the **Playlist** → page 154.

Change the track on the media main menu

The tracks of the media sources being played back can be successively run through with the arrow buttons → page 154, *Track selection from the track list*.

It is **not** possible with the arrow buttons to switch to playback from a playlist. Playback from a playlist needs to be manually started from the track selection menu → page 154, *Track selection from the track list*.

Operation through the media main menu

Action	Effect
<i>Briefly touch the function button</i> 	Within less than 3 seconds of the track's length, switches the beginning of the previous track.
<i>Briefly touch the function button</i> 	Within more than 3 seconds of the track's length, switches to the beginning of the current track.
<i>Press and hold the function button</i> 	To the next track. After the last track, it returns to the first track of the current data storage unit.
<i>Press and hold the function button</i> 	Fast rewind.
<i>Press and hold the function button</i> 	Fast forward.
Touch the function button  once, <i>briefly</i> .	Playback is interrupted. The function button  changes to  .
Touch the function button  once, <i>briefly</i> .	Playback is resumed. The function button  changes to  .

Track selection from the track list

To open the track list in the *MEDIA* main menu, press  **OR** turn the knob. The track about to be played back is highlighted.

Search the track list and touch on the desired track. When track information is available, the track number and name or the names of the files (MP3) are displayed instead of the **Title + no.** ¹⁾. The track title list may not be supported by the source.

 Tracks, folders and playlists can also be marked, by turning the settings knob, and accessed/opened by pressing the knob.

Specific media settings

Opening the Media settings menu

In the *MEDIA* main menu, touch the  function button.

Function button: effect

Sound: opens the **Sound settings** menu → page 166.

Mix/Repeat, including subfolders: subfolders are included in the selected playback mode → page 152.

Bluetooth: opens the **Bluetooth settings** menu.

Remove: remove the data unit (USB data storage unit or SD card) from the system. The respective function button is disabled after the data storage unit is successfully removed.

Wired or wireless connections

Introduction

Some external devices can be connected to the radio with or without wires (if existing) in the vehicle.

The type and number of connections with or without wires depend on the country and the vehicle. Within a range of different models and in special models the connections may reveal differences.

For the wired connections use only original cables from the device or - if available - the factory supplied cables for the respective vehicle. 

SD card slot

Only 32 mm x 24 mm x 2,1 mm (1.26 x 0.94 x 0.083 inch) **or** 32 mm x 24 mm x 1.4 mm (1.26 x 0.94 x 0.055 inch) SD cards can be inserted into the SD card slot → Fig. 111 .

Only supported audio files are shown → page 151. Other file types are ignored.



Inserting an SD card

Insert the SD card carefully into the SD card slot with the chamfered edge up and the inscriptions to the left (contact surfaces downward).

If the SD card cannot be inserted, check the insertion position and the SD card.

Ejecting the SD card

To prevent data loss, an inserted SD card **must** be prepared for ejection by the following procedure:

▶  **SETUP** ▶  **Safely remove.** ▶  **SD card.**



Next, press the inserted SD card. The SD card "jumps" into ejection position and can be removed. 

Unreadable SD card

When a memory card with unreadable data is inserted, a corresponding message is shown on the radio's display.

 Volkswagen is **not** responsible for SD cards and same are not offered together with the radio. It is necessary to have an SD card to use it on the radio.

 Do not use any SD card adapter.

 An SD card with navigation data cannot be used as storage for other files, the saved files are not recognized by the radio. 

¹⁾ Depending on the source.

Playback of an SD card

- Carefully insert the SD card into the SD card slot with the chamfered edge up and the inscriptions to the left of the SD card slot → Fig. 111 (6).
- To remove the SD card, first see the system settings and execute the **Safely remove source** action. Briefly touch the SD card so it “springs” out to removal position.
- Press the radio **[MEDIA]** button.

Playback is taken up from the last used media source. To playback the SD card, press **[]**.

When navigating the folders, use the **[←]** function button and the knob. Press **[→]** to go to the higher level of the folders and rotate the selector button to select the desired folder.

To change to the next or previous track, press one of the function buttons.

Keep one of the arrow buttons pressed for a few seconds to move the playback forward or backward.

During playback of the SD card, some function keys are available at the bottom of the display. The active buttons are highlighted.

USB Connection

The USB multimedia port is located on the front part of the device → Fig. 111 (5).

Audio files on an external data storage unit connected to the USB port  can be played back and controlled by device.

USB data manual are referred to in this manual as external data media, which contain playable files (e.g. MP3 player, iPods™ and pen drives).

Only supported audio files are shown. Other file types are ignored.

Playback begins automatically if there are stored and readable audio files in the data storage units.

The additional external data storage unit controls (access track changes, track selection, and playback modes) are detailed in the respective chapters → page 150.

Instructions and restrictions

The number of USB ports  and compatibility with Apple™ devices, among other Media Players, may vary depending on the equipment.

The typical USB voltage of 5 V is supplied through the USB  port.

External hard drives with capacity for over 32 GB must be reformatted into the FAT32 file system, depending on the conditions. Programs and instructions to perform such formatting process are available on the Internet, for example.

Considering the wide range of different data storage units and various iPod™, iPad™ and iPhone™ generations, it is impossible to ensure that all functions will be available.

iPod™, iPad™ and iPhone™

Depending on the country and equipment version, iPods™, iPads™ or iPhones™ may be connected to the vehicle's USB port , through a suitable USB cable, and used as audio sources.



Disconnect

Connected data storage units **must** be prepared for removal before being disconnected.

- In the MEDIA main menu, touch the **[]** function button to open the **Media settings** menu.
- **OR:** press the **[SETUP]** radio button.
- Touch the **[Safe remove]** and then select **[← USB]**. The function button is disabled after the data storage unit is successfully removed.
- The data storage unit may be disconnected.

Unreadable data storage unit

If a connected data storage unit contains unreadable data, a corresponding message is shown on the device display.

 If an external Media Player is connected **simultaneously** via Bluetooth® and the USB port  to the device, the Bluetooth® audio connection is automatically disconnected after switching to the USB port.

 If a connected device cannot be recognized, remove all connections and reconnect the devices. Check whether the connection cable is working, if necessary.

 In case of operating faults in connected devices, restart the respective device. This usually solves the issue. ▶

 Do not use any memory card adapter, USB extension cord, or USB-Hubs (USB distributors)!

 Refer to the external data storage unit manufacturer's operating manual.

Connecting an external audio source to the multimedia AUX-IN port

Depending on the type and version of the vehicle, the voice command feature may not be available.

The AUX-IN multimedia port only supports 3.5 mm jack plugs.

The external audio source connected is played back through the vehicle's loudspeakers and **cannot** be controlled by the device.

Connected external audio sources are indicated by **AUX** on the display.

Connecting an external audio source to the AUX-IN multimedia port

- Reduce the volume on the radio.
- Connecting an external audio source to the AUX-IN multimedia port.
- Start playback on the external audio source.
- Press the radio **[MEDIA]** button to display the available media sources selection menu → page 150.
- Press the function button **[**]**.

The **playback volume** of external audio sources must be adjusted to the volume of remaining audio sources.

Specificities regarding the use of external audio sources in the AUX-IN multimedia port

Action	Effect
Selection of another audio source on the device.	The external audio source continues to play in the background.
Stop playback on the external audio source.	The unit stays in the AUX menu.
Remove the plug from the AUX-IN multimedia port.	The unit stays in the AUX menu.

 When the playback of the external audio source is finished or is disconnected from the multimedia AUX-IN port, the radio stays on the **AUX** menu.

◀  There may be noise interferences if the external audio source is used on the vehicle's 12 V power outlet.

 Read and follow the external audio source manufacturers operating instructions. ▶

Connecting external audio sources via Bluetooth®

Connecting an audio source via Bluetooth

The Bluetooth® audio mode can be displayed by the  icon in the upper row.

In Bluetooth® audio mode audio files from a Bluetooth® audio source connected via Bluetooth® can be played back (for example a mobile phone), using the vehicle's loudspeakers (audio Bluetooth® playback).

Requisites

- The Bluetooth® audio source must support the Bluetooth® A2DP profile.
- In the **Bluetooth settings** menu, the **[BT Audio (A2DP/AVRCP)]** function must be enabled → page 165.

Start audio playback in Bluetooth®

- Lower the base volume on the radio .
- Enable Bluetooth® visibility in the external Bluetooth® audio source (e.g. mobile phone).
- Press the radio **[MEDIA]** button.
- Touch the function button → [Fig. 127](#) and select **[BT audio]**.
- Touch the **[Search device]** function button to pair an external Bluetooth® audio source for the first time.
- **OR:** select from the list of external Bluetooth® audio sources.
- **OR:** pair through the **Bluetooth Settings** menu → page 165.
- Follow the instructions for other procedures on the radio display and the Bluetooth® audio source display.

Playback of the Bluetooth® audio source must be initiated manually, if necessary. ▶

Whenever the Bluetooth® audio source playback ends, the device remains in the Bluetooth® audio mode.

Playback control

Control of the Bluetooth® audio source through the device depends on the connected Bluetooth® audio source.

In media readers that support the Bluetooth® AVRCP profile, playback may be automatically initiated or interrupted from the Bluetooth® audio source, if it is switched to Bluetooth® audio playback or other audio sources. In addition a display of the track or a track change is possible through via the device.

 Due to the wide variety of Bluetooth® audio sources, some of the functions described herein may not operate properly.

 To operate the multimedia mode with the Bluetooth® device connected, read and follow the manufacturers use instructions.

 Use only with devices that support Bluetooth® technology. For further information on Bluetooth® products compatibility contact a Volkswagen dealership or look up on the Internet.

Phone

Introduction

The phone functions detailed below can be accessed through the device when there is an active paired and connected mobile phone.

The mobile phone must support the **Bluetooth®** function in order to establish a connection between the mobile phone and the device.

If no mobile phone is connected to the device, phone control will not be available.

Instructions to use mobile phones in vehicles without external aerial connection.

Phone menu displays vary depending on the functions available on the mobile phone model. There may be differences depending on the model used.

Follow the instructions to use mobile phones in vehicles without external aerial connection → page 263.

Use only with units that support Bluetooth® technology. Additional information about products that support Bluetooth® technology may be obtained at Volkswagen Dealerships or via the Internet.

Refer to the mobile phone and accessory supplier's operating manual.

Call interruption and reception flaws may occur in certain "transmission blackout areas".

Most electronic devices are shielded from HF signals (high frequency). In some rare cases, however, electronic devices may not be shielded against the HF signals of phone controls. This may result in damages.

WARNING

Using mobile phones while driving may distract drivers and cause accidents.

- Always drive carefully and responsibly.
- Adjust sound volume settings to allow the driver to hear external warnings and sounds (e.g. emergency service sirens)
- In locations with partial or lack of mobile coverage, and depending on the circumstances (tunnels, garages and underground passages) telephone call may be hindered, preventing the use of mobile devices (including emergency calls).

WARNING

If a mobile phone is not secured or not properly secured in the vehicle, it could be flung through the interior during a sudden driving or braking manoeuvre, or in the event of an accident. This can cause injuries.

- Always attach mobile phones properly and out of airbag triggering areas while driving.

WARNING

Mobile phones can cause interference when positioned nearby heart pacemakers.



- Keep a minimum distance of 20 centimetres between the mobile phone's antenna and the heart pacemaker, since the former may interfere with the latter.

- Do not carry activated mobile phones in chest pockets directly over heart pacemakers.
- Turn off mobile phones immediately whenever there is suspicion of interference with pacemakers.

NOTICE

High speed, unfavourable weather and road conditions, as well as poor network connection may hinder or interrupt mobile phone calls inside the vehicle.

Special precaution areas

Please refer to  and  at the start of the chapter on page 157.

Switch off mobile phones in areas with risk of explosions. Such areas are very common, although not often identified as such →  in *Introduction* on page 157. Some of these areas are:

- Areas with pipes and tanks containing chemicals.
- Lower decks in ships and ferries.
- Areas nearby vehicles powered by liquid gas (e.g. propane or butane).
- Areas with chemicals or other particles such as flours, dust, or metallic dust in the atmosphere.
- Any other area where the vehicle engine must be switched off.



WARNING

Switch off mobile phones in areas with risk of explosion.

NOTICE

Mobile phones must always be turned off in locations in which their use is prohibited. The radiation generated by mobile phones may cause interference with delicate medical and technical equipment, which may hinder or damage such devices.

Bluetooth®

Please refer to  and  at the start of the chapter on page 157.

Bluetooth®

Bluetooth® technology connects mobile phones to the vehicle's phone controls. A single pairing process is required in order to use the phone controls with mobile phones equipped with Bluetooth®.

- ◀ Some Bluetooth® mobile phones are recognized and connected immediately upon switching on the ignition, if such phones have been previously connected. At the same time, the mobile phone and its embedded Bluetooth® feature must be activated, and all active Bluetooth® connections with other devices must be disconnected.

Bluetooth® radio communication is free of charge.

Bluetooth® is a registered trademark of Bluetooth® SIG, Inc.

Bluetooth® Profiles

Whenever mobile phones are connected to the phone controls, data will be exchanged through one of the Bluetooth® profiles.

Phone use via Bluetooth® Hands-Free-Profile (HFP):

- If mobile phones are connected via HFP with phone controls, wireless calls can be made via the hands-free device. In this case, the external aerial *cannot* be used. Instructions to use mobile phones in vehicles without external aerial connection.

Music playback via Bluetooth® Advanced Audio Distribution Profile (A2DP):

- Bluetooth® profile to transfer audio signals with stereo quality.

Playback control via Bluetooth® Audio Video Remote Control Profile (AVRCP):

- Bluetooth® profile to display track information and playback controls in mobile devices.

Pair up and connect the mobile phone to the radio

 Please refer to  and  at the start of the chapter on page 157.

In order to operate a mobile phone via the radio unit, both devices must be paired **once**.

Pairing must be performed while the vehicle is stationary.

Requisites

- Ignition switched on.
- Remove the headset connection to the mobile phone if necessary.
- The **Bluetooth**[®] function must be enabled and visible on the phone and radio.
- The **key blocking** feature must be unlocked on the mobile phone.

Follow the owner's manual of the respective mobile phone.

During the pairing process, the mobile phone's keypad must be used. The mobile phone must be prepared for such process.

Initiate mobile phone pairing

- Press the **PHONE** button.
- Touch the **Search phone** function button.

After the process is completed, all names of Bluetooth[®] devices found are displayed.

- Select the mobile phone from the list of Bluetooth[®] devices found.

Then the device and the mobile phone will be connected. Additional mobile phone or radio entries may be required to conclude their connection.

- Confirm successful pairing in the mobile phone, if necessary.

Depends on the mobile phone:

- Insert the PIN code displayed on the radio screen into the mobile phone and confirm.

OR:

- Compare the PIN code shown on the radio display with the PIN code shown on the mobile phone. If the PIN code matches, it must be confirmed in **both** devices.

After successfully completing the pairing process, the main menu **PHONE** is shown and the contact list and list of calls stored in the mobile phone are automatically loaded. Confirm on the mobile phone, if necessary.



The duration of the loading process varies depending on the amount of data stored in the mobile phone. After completing the loading process, the data of the device will be available.

Pairing and connecting mobile phones

Multiple mobile phones can be paired to the device. However, only **one** mobile phone can be connected to one device at any given time.

When turning the radio on, the unit automatically connects to the last mobile phone connected. If it is not possible to connect to the last mobile phone used, the phone control automatically attempts to connect to the next mobile phone in the list of paired phones.

The **maximum** range of a Bluetooth[®] connection is approximately **10 metres**. Active Bluetooth[®] connections are interrupted if such range is exceeded. The connection will be **automatically** re-established as soon as the device is in reach of the Bluetooth[®] range.



 Refer to a Volkswagen Dealership for more information on mobile phone connections and pairing. 

Switching off phone controls

 Please refer to  and  at the start of the chapter on page 157.

- End active calls.
- Switch off the ignition.
- Remove the key from the ignition.
- Switch off the mobile phone.

If the vehicle key remains in the ignition cylinder after switching off the ignition, phone controls **will not** be switched off. Phone controls are only switched off a few minutes later (factory settings: approximately 15 minutes).

 If mobile phones were connected with phone controls, the mobile phone transmission unit remains active after switching off phone controls. Switching of the mobile phone may be required. 

Phone control description

📖 Please refer to ⚠️ and ⌚ at the start of the chapter on page 157.

Some features and settings are only available while the vehicle is stationary and are not supported by all mobile phone brands.

The range of possible settings depends on the country, unit, and the vehicle's equipment specifications.

Phone controls can recognize up to 20 devices.

Respectively, devices can be connected via the Hands-Free-Profile (HFP) and the Advanced Audio Distribution Profile (A2DP).

User profile assignment

Connected mobile phones are stored in the phone controls under a user profile.

Up to 4 user profiles can be assigned in phone controls. If another mobile phone is paired, the profile with longest idle time is automatically deleted.

Contact list, favourite numbers (speed dial buttons) and **User profile settings** menu settings are stored in the user profile.

If a mobile phone is reconnected to the phone controls, the respective settings and data will be available once again.

If a mobile phone's contact list entries are changed while connected, contact list data can be manually updated via the **User profile settings** menu → page 165. The contact list will be automatically updated upon the next mobile phone connection (e.g. during the following vehicle use).

⚠️ WARNING

Loose or unsecured mobile phones may be flung through the interior and cause injuries in case of sudden evasive or breaking manoeuvres or in the event of accidents.

- While the vehicle is in motion, always secure mobile devices properly outside the airbag deployment zones or stow them away safely.

🗣️ Using mobile phones in the vehicle may cause loudspeaker noises.

PHONE main menu

📖 Please refer to ⚠️ and ⌚ at the start of the chapter on page 157.

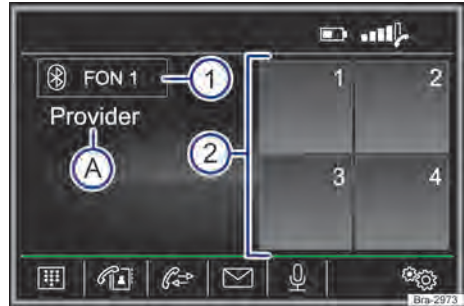

Fig. 129 The telephone main menu.



Fig. 130 Call details.

Opening the Phone main menu

Press the **PHONE** button.

Telephone main menu function buttons

Function button: effect

- ① Name of the paired mobile phone or selected user profile. Touch to connect or pair to another mobile phone.
- ② Favourites (speed dial buttons) to which contact list numbers can be assigned → page 164.
- ☐ Open a numeric keypad to enter a phone number → page 162.
- ☐ Open the contact list of the paired mobile phone → page 162.
- ☐ Open call lists of the mobile phone paired → page 163.
- ☐^{a)} Open the message list (SMS) of the mobile phone paired.

Function button: effect

- Touch the function button to enter a phone number through voice command.
- Open the **Phone settings** menu → page 164.
- Touch to **answer** a call.
- Touch to **end** a call.
OR: touch to **reject** calls received.
- Touch to mute sound during a call. Touch the function button to unmute the sound.

a) Depends on the mobile phone.

Phone control symbols and displays

Display: meaning

- Name of the mobile network carrier in which the SIM card of the paired mobile phone is registered.
- Stored name or phone number display.
- Battery charge status of the connected mobile phone.
- Intensity of the mobile communication transmission signal currently available.
- Displays an active Bluetooth[®] connection. <

During a phone call

Please refer to and at the start of the chapter on page 157.



Fig. 131 During a phone call.

When a connection with the dialled phone number has been established, the *PHONE* main menu display switches to *Phone call* → Fig. 131.

Function buttons and displays: action and effect

- Touch to switch off the mobile phone microphone during a call (the function button changes to).
- Touch to switch on the mobile phone microphone during a call (the function button changes to).
- Display of the call duration and call number or stored name.
- Touch to end a call.
- Battery charge status of the connected mobile phone.

Functions available during a phone call

Possible functions

- Mute mobile phone microphone** Touch the function button . The mobile phone microphone is muted (the function button changes to).
- Unmute mobile phone microphone** Touch the function button . The mobile phone microphone is unmuted (the function button changes to).
- Starting phone calls via mobile phone** Touch the function button and select **Hands-free**. The hands-free function is disabled and the call is directed to the mobile phone
- Starting phone calls via the mobile phone controls** Touch the function button and select **Hands-free**. The hands-free function is enabled and the call is directed to the mobile phone controls. <

Enter phone number menu

Please refer to  and  at the start of the chapter on page 157.



Fig. 132 Enter phone number menu.





Fig. 133 Enter phone number menu (select contact from the list).

Enter phone number menu functions.

Touch the  function button to access the *Enter phone number* menu.

Possible functions

	Touch the  Voicemail function button to establish a connection.
Call voice mailbox	If a voice mailbox number has not been stored, enter the calling number and confirm by pressing  .
	Previously saved call numbers can be edited in the User profile settings menu → page 165.
Enter phone number	Enter phone number via the keypad. Touch the function button  to establish a connection.

Possible functions

Select contact from the list	Enter the first letter of the contact name via the keypad. Possible entries are shown in the contact list. Search the contact list and touch the desired contact to call.
Enter country code	When entering country codes, instead of entering the two first digits (e.g. "00"), it is possible to enter the symbol "+". Touch and hold the function button  for approximately 2 seconds to enter the + character.

Phone contacts list menu



Please refer to  and  at the start of the chapter on page 157.



Fig. 134 Contact Menu (contact list).



Fig. 135 Search mask.

After the first pairing process, it may take a few minutes until the paired mobile phone's contacts¹⁾ become available on the device. This process can take up to approximately one hour, depending on the volume of data to be transferred. Confirm the transmission process on the mobile phone, if necessary.

Contacts can also be accessed during calls.

Opening the Contacts menu

Touch the function button  to access the *Contact list (contacts)* menu.

Possible functions

Select contact from the list	<p>Search the list and touch the desired contact to call.</p> <p>OR: if multiple phone numbers are stored for the same contact, touch the contact and then the desired phone number to call.</p>
Search contacts through the search mask.	<p>Touch the contact surface  → Fig. 134 to open the search mask.</p> <p>Enter the desired name into the search mask → Fig. 135.</p> <p>The appropriate number of events is shown to the right of the search field. Touch the function button to switch to list view.</p> <p>Search the list and touch the desired contact to call.</p>

 Phone menu availability varies depending on the mobile phone used.

Call list menu

 Please refer to  and  at the start of the chapter on page 157.

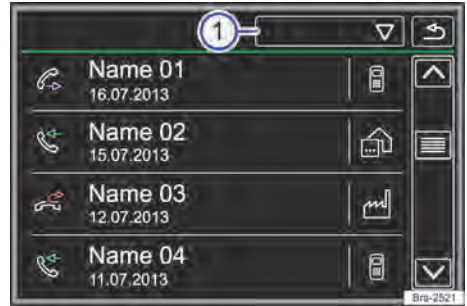



Fig. 136 Call Menu (call lists).



Whenever a phone number is stored as a contact, the stored name will be displayed instead of the call list number.

Opening the Calls menu

Touch the function button  to access the **Calls** menu.

Touch the function button  → Fig. 136 . Select the desired call list: **All**, **Lost**, **Ignored** or **Answered**.

Display

	[Missed]: displays the numbers of missed and unanswered calls.
	[Dialled]: displays phone numbers selected via the mobile phone and the device's telephone control.
	[Received]: displays numbers of calls taken via the mobile phone and the device's telephone control.

 Call list availability varies depending on the mobile phone used.

¹⁾ Depending on the unit model, only contacts stored in the phone memory are loaded.

Favourites (speed dial buttons)

📖 Please refer to ⚠️ and ⌚ at the start of the chapter on page 157.



Fig. 137 The telephone main menu.

A total of 4 phone numbers from the contact list can be stored as favourites.

All favourite numbers must be assigned manually and then attributed to a user profile.

Favourite functions

Possible functions	
Assign favourite	In the <i>PHONE</i> main menu, touch one of the free function buttons. Select the desired contact from the contact list. If more than one phone number is stored for the desired contact, select the desired number.
Edit favourite	In the <i>PHONE</i> main menu, <i>press and hold the favourite entry</i> until the <i>Contacts</i> menu opens. Select the desired contact from the contact list. If more than one phone number is stored for the desired contact, select the desired number. To close the <i>Contacts</i> menu without applying changes, touch the function button  .

Possible functions

Delete favourite	Favourite entries can be deleted in the <i>User profile settings</i> menu, under the <i>Manage favourites</i> option → page 165.
Call favourite	In the <i>PHONE</i> main menu, briefly touch the function button of the respective favourite contact <i>assigned</i> to call the stored phone number.

 Contacts stored as favourites are not automatically updated. If a contact stored as favourite in the mobile phone is changed, the function button must be reassigned. ◀

Phone settings

📖 Please refer to ⚠️ and ⌚ at the start of the chapter on page 157.

Open the Phone settings menu

- In the *PHONE* main menu, touch the  function button.
- Touch the function button in which settings must be made.
- Changes are automatically applied after closing a menu.

Function button: effect

Select telephone: select the Bluetooth® device from the list to connect.

Search phone: touch to connect a new Bluetooth® device.

Bluetooth: opens the *Bluetooth settings* menu → page 165.

User profile: opens the *User profile settings* menu → page 165.

Mobile phone reminder: if a Bluetooth® connection with the mobile phone is established, the message “Don't forget your phone” appears after switching off the ignition. ◀

Bluetooth® settings

📖 Please refer to ▲ and ⌚ at the start of the chapter on page 157.

Open the Bluetooth settings menu

In the **PHONE** main menu, touch the  function button.

OR: press the **SETUP** button.

Then, touch the **Bluetooth** function button.

Touch the function button in which settings must be made. Changes are automatically applied after closing a menu.

Function button: effect

Bluetooth: touch to switch off Bluetooth®. All current connections will be interrupted.

Visibility: switch Bluetooth® visibility on or off.

Visible: Bluetooth® visibility enabled.

Invisible: Bluetooth® visibility disabled. Bluetooth® visibility must be switched on to pair external Bluetooth® devices to the radio.

Name: shows or changes the device name. This name is shown in other Bluetooth® devices under the Bluetooth® settings.

Paired devices: shows the paired device. Disconnect and connect individual Bluetooth® devices and Bluetooth® profiles.

Search devices: search active and visible Bluetooth® devices in range of the device. The **maximum** range is approximately **10 metres**.

BT Audio (A2DP/AVRCP): if an external audio source is to be connected to the device via Bluetooth®, this function must be enabled.

User profile settings

📖 Please refer to ▲ and ⌚ at the start of the chapter on page 157.

Function button: effect

Manage favourites: edit favourites → page 164.

 **All:** all favourites are deleted.

Favourite: touch to delete the stored number.

Free function button: touch to store a contact list number as favourite.

Function button: effect

Voice mail No.: enter or edit the voice mailbox number.

Sort by: set the contact list sorting sequence (**Last name** or **Given name**).

Import contacts: import the contact list of the paired phone or update imported contact lists.

Select a ringtone: select a ringtone from a list of ringtone presets. The ringtone is played and stored after exiting the submenu.

Delete other profiles: delete some or all inactive user profiles.

Settings

Menu and system settings

According to the vehicle version or type the menu and system functions and setting options may vary.

Open the System settings menu

- Press the radio **SETUP** button → ▲.
- Press the function button area of the mode to which the introduction of settings is intended.
- Changes are automatically applied upon closing a menu.

Function button: effect

Sound: adjust sound and volume settings → page 166.

Display: display settings.

Turn display off (in 10 s): if the function is enabled and the device remains idle, the display is automatically shut down after 10 seconds. The display is switched back on by touching the display or pressing a button.

Brightness level: select the display brightness level.

Touchscreen sound: confirmation sound when touching a function button enabled.

Display time in Standby mode: the current time is shown on the display while in Standby mode.

Date/time: to enter date/time settings

Time: manual current time setting.

Function button: effect

Time format: to define the preferred time display format (12 or 24 hours).

Daylight saving time: sets the daylight saving time automatically.

Date: to set the current date.

Date format: to define the preferred date display format (dd-mm-yyyy, yy-mm-dd or mm-dd-yy).

Additional keypad languages^{a)}: select additional keypad languages.

Units: define the units display in the vehicle.

Bluetooth^{a)}: Bluetooth[®] settings → page 165.

Safe removal: remove the desired data storage unit safely from the system. The function button is disabled after the data storage unit is successfully removed.

Default settings: the return to default settings is disabled as selected in the **Entries and settings applied**.

System data: display of system data (unit number, hardware/software versions.)

Update software: update the software version.

Copyright: copyright information.

^{a)} Depending on the unit and the country.

WARNING

Accidents and injuries can occur if the driver is distracted.

- Never proceed with settings while driving.

 To make the best of the radio's features and optimal operation it is important that the date and time be correctly set.

Sound and volume settings

According to the vehicle version or type the sound and volume function and setting options may vary.

Press the **SETUP** button and then select **Sound**.

Function button: effect

Volume: volume settings.

Max. start volume.: set the maximum switch-on volume.

Function button: effect

Speed-dependent volume control: set volume adjustments based on the vehicle's speed. The audio volume is increased automatically as the speed increases.

Entertainment dimmer: set warning volumes.

AUX volume: set the playback volume of audio sources connected to the AUX-IN multimedia port (**Low**, **Medium** or **High**). Also see → page 166, *Adjust playback volume of external audio sources*.

Bluetooth Audio^{a)}: establish the playback volume of audio sources connected via Bluetooth[®] (**Low**, **Medium** or **High**). Also see → page 166, *Adjust playback volume of external audio sources*.

Balance - Fader: set sound equalization.

The grid shows sound equalization inside the vehicle. To edit sound equalization, touch the desired position in the vehicle interior display or use the arrow buttons to sequentially change settings. To centre sound equalization in the vehicle interior display, touch the function button between the arrows.

Bass - mid - treble: set sound characteristics (bass - mid - treble).

Touchscreen sound: confirmation sound when touching a function button enabled.

^{a)} Depending on the country and the device.

Operation mode of the volume increase as a function of speed

The speed-dependant volume increase automatically adjusts the volume based on the vehicle's speed.

The volume increase is set in levels from 1 to 7.

If a low value is set, the volume is slightly adjusted at higher speeds, if the set value is high, the volume increases sharply. At level 0 the volume increase as a function of the vehicle's speed is disabled.

Adjust playback volume of external audio sources

Whenever the playback volume of an external audio source must be raised, first lower the default volume of the device.

If the connected audio source has **very low volume**, increase the **output volume** in the external audio source. If this procedure is not sufficient, set the **on volume** to **Medium** or **High**.

If the external audio source connected has **distorted or very high volume**, lower the **output volume** in the external audio source. If this procedure is not sufficient, set the **on volume** to **Medium** or **Low**.

⚠ WARNING

Accidents and injuries can occur if the driver is distracted.

- Never proceed with settings while driving.

VW Play

Welcome to VW Play

Get ready for an unforgettable radio experience!

The setup wizard will guide you through a few simple steps to set up your radio. You will set up a user profile, date and time, and connect your radio to Bluetooth® and the Wi-Fi network. Follow the instructions and select **Need help?** if you have any doubts.

⚠ WARNING

Initial settings require attention and time and must only be performed while the vehicle is parked.

i If there is no Wi-Fi connection available, some of the radio features cannot be configured during the initial setup.

Device overview

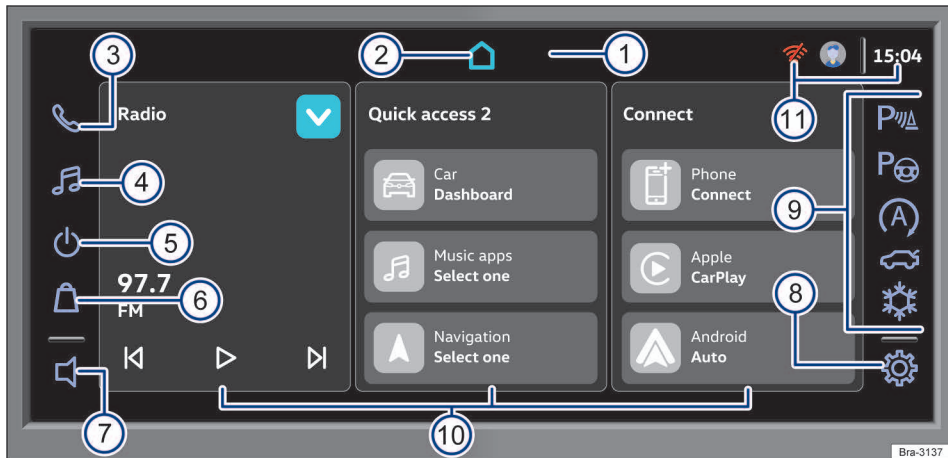

Fig. 138 Control overview.

The radio is supplied in different versions of the device which are distinguished from each other by its group of functionalities, inscriptions and button functions as well as by the lay out of the controls.

- ① **Display:** touchscreen.
- ② **Home screen shortcut:** back to home screen.
- ③ **Phone:** press to open the phone interface.
- ④ **Media:** press to open the radio and media interface.

- ⑤ **Power:** press to enable the mute feature. Hold for 3 seconds to enable the *stand-by* feature.
- ⑥ **App store:** press to open the application interface.
- ⑦ **Volume:** press to adjust the volume.
- ⑧ **Settings:** press to open the settings.
- ⑨ **Virtual switches:** controls for assist systems, boot lid opening and air conditioning, if available.

- ⑩ **Quick access screens:** → page 168.
- ⑪ **Clock and status icons:** press to change user profile information. If connected, status of the Bluetooth® and Wi-Fi connection, phone battery status, and mobile network signal information.

Quick access screens

To facilitate home screen browsing, the user can access menus through shortcuts. There are three shortcut combinations available:

To configure the quick access screen, hold the quick access screen for three seconds and select the best combination.

Home screen shortcuts can access some functions that require Bluetooth® connection, Wi-Fi connection and specific apps.

Radio

Introduction

Follow the national rules and legal provisions when using the radio.

Other additional electric devices connected to the vehicle may interfere with the receipt of the broadcast radio signal and cause noises in the speakers.

 Parking lots, tunnels, tall buildings or mountains may interfere with unit signal reception.

 Metal-coated stickers or films may hinder reception in vehicles with windscreen aerials.

Unit operation







Fig. 139 Main menu: radio.



Open the main menu

Press the media button  and select  Radio. Press the arrow .

Tune into stations



Select a frequency range .

To choose a station, press the arrow buttons  /  to browse through available stations. Or press  and select the desired station in the frequency range.

The user can also enter the number of the desired station, press , enter the station number and press .

Store stations

The currently tuned in radio station is displayed in the centre of the display.

 To store a station, turn into the station and press . The stored station will appear in a position on the bottom of the display. Briefly press the button to access the station.

Up to 6 stations can be stored for each user profile. 

Replace stored radio stations

To replace stored radio stations, tune into the station and briefly press the position to store the new station.

Scan

To scan stations in the **Media** menu, press **Radio settings** and press **Search stations**.

Or press a media button **Ⓜ** and then **Update**.

Delete stored stations

To delete stored stations, press the **Settings** button **⚙**, in the **Media** menu, select **Radio settings** and press **Delete presets**.

Media

Introduction

“Media sources” are referred to as audio sources that contain audio data in different data storage units, such as external MP3 Players or audio files. These audio files can only be played by the respective units or through the respective radio system's audio input ports/interfaces (USB port or Bluetooth® interface).

Copyrights

Audio and video files stored in data media may be subject to applicable national and international copyright and data protection laws. Legal provisions must be followed.

i Volkswagen takes no responsibility for damaged or lost files.

File and database requirements

Supported listed file formats are simply referred to as “audio and video files”.

Media source	File system	Playing requirements
Data storage unit specified as per USB 2.0	FAT16, FAT32, NTFS, exFAT, Ext3 and Ext4	<ul style="list-style-type: none"> – Audio files MP2 (.mp2), APE (.ape), OGG (.ogg), OGA (.oga), OPUS (.opus), MP3 (.mp3), WMA (.wma), WAV (.wav), FLAC (.flac), and AAC (.aac). – Video files WMV (.wmv), MKV (.mkv), MOV, exFAT, AVI (.avi) and MP4 (.mp4). – At most 2.000 elements per folder level. – Max. 20,000 audio and video files per data storage unit. Max. size of a FAT32 data system file: 4GB.
	Ⓜ Audio file reproduction via Bluetooth® ^{a)} .	– External Media Player must support Bluetooth® A2DP profile.
External audio source playback via the USB port.		– External data storage unit in the USB ↔ .

a) Bluetooth® is a registered trademark of Bluetooth® SIG, Inc.

i Volkswagen may not be held liable for damaged or lost files in data media.

Air conditioning control



Fig. 140 Air conditioning in multimedia.

Control the air conditioning via the VW Play screen

Press the **MENU** button on the climatronic, or the **Ⓜ** button on the VW Play screen.

Air conditioning functions → page 93.

Media operation





Fig. 141 Main menu: Media.





Open the main menu

Press the media button  and select the desired media source. Press the arrow .

The following media sources are available:

-  USB: external data storage unit in the USB port.
-  Phone: Bluetooth® audio.



Basic functions

- To browse through media tracks, press the  /  buttons.
- To stop playing media, press .
- To resume playing, press .
- Media can be sorted by artist, album, songs, genres and video files.

Random mode

Random audio playback.

Repeat mode

- To repeat all tracks, select .
- To repeat only the current track, select .

NOTICE

The screen is blocked for video playback and games while driving.

Connect







Fig. 142 Connect via Bluetooth.





Fig. 143 Phone function.

Connection via Bluetooth®

- To connect the Bluetooth®, press the settings button  and touch .
- Press  and then select "Add device".
- The radio unit will automatically search for devices available (turn on Bluetooth® visibility in on your device). For more information, refer to the audio device's instruction manual.
- To establish a connection, select the name of the device to connect. Compare the code shown on the radio display and the code shown on the mobile phone. If the code matches, confirm the code to connect.
- Depending on the radio version, 2 devices can be connected simultaneously. To define the function on the device, select the phone button  to use phone functions and select the media button  to use media functions → Fig. 142.

Bluetooth® audio function

To enable Bluetooth® audio mode, the audio button  must be active after connecting. In this mode, audio files from audio sources connected via Bluetooth® (e.g. mobile phone) will be played on the vehicle's loudspeakers.

After connecting to a Bluetooth® audio source, follow the functions in the Media menu  → page 170.

Phone function





Phone menu displays depend on the functions available on the used mobile phone model. There may be differences.

To enable Bluetooth® phone mode, the phone button  must be active after connecting. In this mode, the user can access phone contacts, make and receive calls using the vehicle's loudspeakers.







Receiving phone calls:



- Press  to receive a phone call.

Making phone calls:

- In the phone function , enter the number to call and press .
- Or open the contact list by pressing the contacts button . Select the contact to call and press .
- To search through the contact list, press the contacts button  and enter the desired name on the top bar **Search contacts**.

During a phone call:

- Press  to mute the microphone during a phone call. Press  again to unmute the microphone.
- Press  to mute the loudspeakers
- Press  to place an active call on hold. The user can make or answer other calls with a call on hold.
- Press  to resume the call on hold.
- Press  to open the keypad.
- To end a call on hold, press the hang up button .



 Up to 1,000 contacts can be synchronized via Bluetooth® connection. 

Wi-Fi



Fig. 144 Connect Wi-Fi.

Connect to Wi-Fi network

- To connect Wi-Fi, press the settings button  and touch **Connect**.
- Slide the selector to enable the Wi-Fi connection; the radio will automatically scan all available networks.
- Select the name of the desired Wi-Fi network. In case of a secure Wi-Fi network, enter the password and press .
- After connecting, the icon  will appear on the top left corner.

Forget network

Once the radio connects to a Wi-Fi network, it will automatically connect to the same network whenever it is available.

To avoid automatic connection, touch **Forget network** in the connected network, in order to end the connection. 

App store

Introduction

The App store may not be available in all countries.

The app store is the right tool to search and download the perfect applications for your daily routine. 

Some applications are factory-installed.

Before using applications, read the respective use terms and privacy policies. 

App store

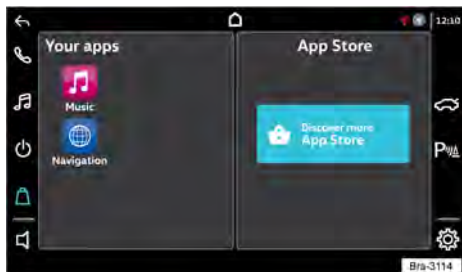



Fig. 145 App store.

To download applications on the App store, the user must be connected to a Wi-Fi network and logged with the Volkswagen ID.

To sign up for a Volkswagen ID, access the VWID login page or the **My Volkswagen** application and fill out all registration information required.

To log in, press the **App-store**  menu or drag the screen to the left twice to open the quick access screen, press **Start session** or read the code with the phone camera.

After logging in, the information is loaded on the home page.

Download applications

Search for the application you want to download. Select the application and press **Download**.

The download will begin and the status will be shown on the top corner of the page. Press **Cancel** before the download is completed to cancel.

After the download ends, press **Open** to open the application and its features. Installed applications are available on the left-hand side of the screen.

Basic functions

- Press **My Apps** to access installed apps.
- Press **Settings** to access App-store settings. In this section, the user can check the App-store software version and the use terms and conditions.
- To update installed apps, press **Update** to check for available updates.
- To delete installed apps, select the **Settings**  menu, select the app to delete in the **Apps** item and press **Uninstall**.

NOTICE

Videos and other functions that may distract the driver are blocked while the vehicle is in motion. 

Apple CarPlay™

Apple CarPlay™ Menu

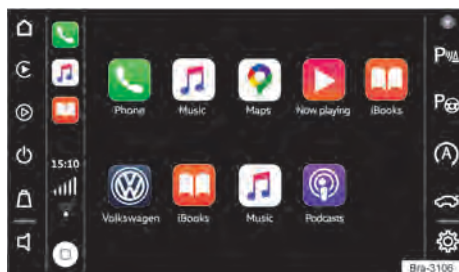

Fig. 146 Apple CarPlay™ Menu.

Establish connection

To use Apple CarPlay™ the mobile device **must** support Apple CarPlay™.

Depending on the mobile phone used, it is possible to connect to the radio with a USB cable or with a wireless connection via Wi-Fi.

When a mobile device is connected for the first time follow the instructions on the radio display and on the display of the mobile device.

Confirm the use of Apple CarPlay™ on the mobile device and the radio display.

End connection

- For USB cable connections: remove USB cable
- For Bluetooth® or wireless connections: follow the instructions shown on the mobile phone.
- Reconnecting to the Wi-Fi network also ends the Apple CarPlay™ connection → page 171.

Specificities

During an active Apple CarPlay™ connection, the following features are enabled: 

- If connected with a USB cable, Bluetooth connections between mobile devices and the radio are **not** possible.
- Phone functions are possible through Apple CarPlay™ and through the radio's phone function.
- If connected via wireless Apple CarPlay™, Wi-Fi connection is unavailable.
- Apple CarPlay™ functions may be limited while driving.
- An active Apple CarPlay™ device cannot be used as a media device on the Media menu.
- Navigation routes are not shown on the instrument cluster display.

NOTICE

Apple CarPlay™ is a software platform from Apple that allows you to access certain applications and features on your mobile phone through your car's Infotainment System touchscreen or mobile phone's voice assistants. Once connected, Apple CarPlay™ mirrors a simplified version of the mobile phone interface optimized for driving. All the generated image and displayed functionalities are controlled by the mobile phone itself in this situation. Therefore, any situation that influences the performance of the mobile phone will directly affect the performance on the Infotainment screen, causing the impression that the Infotainment is faulty, when in fact the functions controlled by the vehicle are operating normally.

 For more information, refer to the mobile device's owner's manual.

Android Auto™

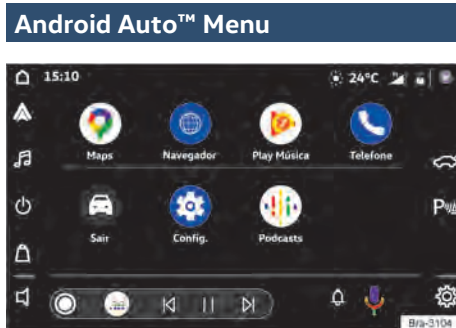

Fig. 147 Android Auto™ Menu

Connect

To use the Android Auto™ the mobile phone **needs** to support Android Auto™ and be connected to the radio with a USB cable or with a wireless connection through Wi-Fi.

Depending on the mobile phone used, an adequate application must be installed to use Android Auto™ on the device.

When a mobile device is connected for the first time follow the instructions on the radio display and on the display of the mobile device.

Press the radio button  to access Android Auto™ functions.

To access radio controls, press the home screen shortcut .

End connection

- Remove USB cable or turn off Wi-Fi connection.
- To return to the home screen, press .

Specificities

During an active Android Auto™ connection, the following features are enabled:

- An active Android Auto™ device may be simultaneously connected to the radio via Bluetooth.
- Bluetooth connections between mobile devices and the radio are **not** possible.
- Telephone functions are possible via Android Auto™. When the Android Auto™ device is simultaneously connected via Bluetooth to the device, the phone function can also be used.

- Simultaneous phone calls via Android Auto™ and via the radio are **not** possible.
- An active Android Auto™ device cannot be used as a media device on the Media menu.
- Navigation routes are not shown on the instrument cluster display.

NOTICE

Android Auto™ is a software platform from Google that allows you to access certain applications and features on your mobile phone through your car's Infotainment System touchscreen or mobile phone's voice assistants. Once connected, Android Auto™ mirrors a simplified version of the mobile phone interface optimized for driving. All the generated image and displayed functionalities are controlled by the mobile phone itself in this situation. Therefore, any situation that influences the performance of the mobile phone will directly affect the performance on the Infotainment screen, causing the impression that the Infotainment is faulty, when in fact the functions controlled by the vehicle are operating

 For more information, refer to the mobile device's owner's manual. <

Settings

Introduction

The range of possible settings depends on the country, unit, and the vehicle's version. <

System settings



Fig. 148 Settings menu.

Open the Settings menu

- Press .
- Select the function for the area for which the settings are to be set. Changes are automatically applied after closing a menu.

Function button: effect

System: system settings.

Bluetooth: Bluetooth® settings.

Visibility: make the Bluetooth® device visible or hidden.

Bluetooth name: show or change the device name.

Device manager: shows paired devices. Disconnect and connect individual Bluetooth® devices and Bluetooth® profiles.

Phone: phone settings.

Bluetooth: Bluetooth® settings.

Ringtone: ringtone settings.

Audio: volume and tone settings.

Sort contacts: sort contacts by first and last name.

Phone reminder: if a mobile phone is connected via Bluetooth®, the message "Don't forget your phone" is shown after switching off the ignition.

Audio: volume settings.

Maximum call volume: to set the maximum initial volume.

Speed-dependent volume: set volume adjustments based on the vehicle's speed.

Navigation warning: sets the volume of the navigation system's directions.

Entertainment dimmer (parking): set the audio playback volume while the parking aid sender is activated.

Ringtone volume: set the ringtone volume.

Media sound: establish media volume.

Phone sound: set phone volume.

BT audio volume: set the Bluetooth® audio volume.

Tone: tone settings.

Equalizer: sound equalization settings.

Balance and Fader: sound distribution settings. The grid shows the current point of balance of the sound inside the vehicle. To change sound distribution, touch the desired position in the vehicle >

Function button: effect

interior display or use the arrow buttons to sequentially change settings. To centre sound distribution in the vehicle interior display, touch the function surface between the arrows.

Touchscreen sound : enable or disable confirmation sound when touching a function button enabled.

Display: display settings.

Turn display off (in 10 s) : if the function is enabled and the device remains idle, the display is automatically shut down after 10 seconds. The display turns back on by touching the screen.

Brightness: to display brightness settings.

Touchscreen sound : enable confirmation sound when touching a button on the screen.

Skins: depending on the vehicle version and mode, radio colour combinations can be changed. In this case, open the App store and download new skins.

Automatic Valet mode : when the door is opened and whenever the key is far from the vehicle, Valet mode is automatically enabled → page 176.

Safe removal: remove the desired USB data storage unit safely from the system. The respective function button is disabled after the data storage unit is successfully removed.

Wi-Fi: Wi-Fi network settings.

enable and disable the Wi-Fi network.

Manage stored networks: settings of stored Wi-Fi connections.

Generate security key: generate a new Apple CarPlay™ wireless connection key.

Find hotspot: search new network connections.

Units: define measurement units.

Language selection: select the desired language.

Date and time: date and time settings.

System data: display of system data (unit number, hardware/software versions).

Welcome video: watch the welcome video again.

Function button: effect

Reset system: reset all or specific settings to factory-settings.

Copyright: copyright information.

Car: vehicle function settings.

Stability control (ESC): activate and deactivate stability control.

Light settings: configure the functions of the lights.

Date and time: date and time settings.

Mirrors and wipers: make settings for mirrors and wipers.

Dashboard: carry out configurations of the functions of the dashboard.

Service settings: access information about the inspection service.

Tires: setting the tire indicators.

Assistance systems: activate and deactivate the assistance systems.

Opening and closing: configure the door opening and closing functions.

Units: define measurement units.

Parking and manoeuvring: configure the parking functions.

Vehicle valet status: enable and disable valet mode.

Factory setting: reset vehicle functions to factory settings.

Media: to make media adjustments.

Audio: volume settings.

Bluetooth: Bluetooth® settings.

Radio settings: radio station settings.

Scan stations: scan stations available in the current frequency range.

Arrow buttons: adjust arrow buttons < and > to switch to the next station in the frequency range or the next stored station.

Delete presets: delete all stored stations.

Safe removal: remove the desired USB data storage unit safely from the system. The respective function button is disabled after the data storage unit is successfully removed.

Apps: app settings.

Sort by: sort apps alphabetically or by installation date.

App management: manage installed apps.

Apps can also be deleted in this section. ▶

Function button: effect

[Wi-Fi]: Wi-Fi network settings.

[Notifications]: vehicle status data.

Settings menu shortcuts

There are shortcuts for some settings on the main page of the Settings menu

- **Screen OFF**: place screen in *stand-by*.
- **Audio**: open audio settings.
- **Connect**: connection settings.
- **Profile**: edit profile settings → page 177.
- **Lights**: edit vehicle light settings.
- **Valet mode**: enable valet mode → page 176.
- **Brightness**: screen brightness settings.

Reset system

To reset the system, press **Settings** and in the **System** menu, press **Reset system**.

It is possible to reset all settings or each setting individually.

Search

When in doubt, use the search bar in the **Settings** menu.

The search will return the most relevant topics related to the keywords entered.

⚠ WARNING

Accidents and injuries can occur if the driver is distracted.

- Never proceed with settings while driving.

⚠ WARNING

Never reset the system while driving.

i To make the best of the radio's features and optimal operation it is important that the date and time be correctly set.

Valet mode



Fig. 149 Automatic valet mode activation.



Fig. 150 Valet mode lock screen.

The valet mode locks the radio and can be activated automatically or manually.

Activate valet mode through the **Settings** menu: press **Screen** and select **Automatic valet mode**. When activated, the radio will be locked 10 seconds after opening the driver door with the engine on → Fig. 149. In keyless vehicles, the radio is locked immediately as the key moves away from the vehicle with the engine on. Enable this feature for greater convenience and security.

If you forget the PIN code, all factory settings and data must be reset. To reset, press **Reset all data and settings** on the display.

PIN code configuration

To configure the PIN code, open the **Settings** menu and select **Valet Mode**. Edit the PIN code on the **Settings** menu and then access the **Profile** and select **Edit PIN code**.

The PIN code must contain 4 digits.

Vehicle valet status

During the period when the car's Valet Mode is enabled, the Valet Status function will provide a report of the events that took place with the vehicle.

On the **Settings** menu, open the **Car** menu and select **Vehicle valet status** to enable this feature.

While Valet Mode is enabled, the Valet status function will be available on the radio screen, allowing the driver to monitor the following information → Fig. 150:

- Maximum speed reached.
- Distance travelled.
- Vehicle doors open, except driver door.
- If the rear lid was opened.
- If the bonnet was opened.

When Valet Mode is disabled, this information is deleted.

Edit PIN code

Open the **Settings** menu, press **Profile**, select **Edit PIN code** and enter the 4 digit code.

User profile

Depending on the radio version, up to 03 user profiles can be configured. The user profile stores memorized radio stations, driving mode (if available in the vehicle), language and applications installed via the VW Play Apps store.

Add new user profile

Press the avatar picture on the top right corner of the screen or open the **Settings** menu and select **Profile**. Select **Create new profile** and enter the desired name and avatar.

Edit avatar image and name

Press the avatar picture on the top right corner of the screen or open the **Settings** menu and select **Profile**. Next, select **Edit name and avatar**.

Change user profile

The vehicle must be stopped to change the user profile.

Press the avatar picture on the top right corner of the screen or open the **Settings** menu, select **Profile** and select the desired profile. If a PIN code is configured, the PIN code must be entered to change the profile.

Transporting

Stowing items of luggage

Heavy objects must always be stowed securely in the luggage compartment and you must ensure that the rear seat backrests are securely engaged in the upright position. Always use suitable securing straps with the fastening rings to secure heavy objects. Never overload the vehicle. Both the payload and the distribution of the load in the vehicle affect driving response and braking distance → .

Stow all items of luggage in the vehicle securely

- Always distribute any loads in the vehicle as evenly as possible.
- Place heavy objects as far forward in the luggage compartment as possible. Position the rear seat backrests securely in the upright position.
- Secure luggage in the luggage compartment to the fastening rings with suitable straps.
- Adjust tyre pressure according to the vehicle load. Refer to the tyre pressure sticker → page 236.
- In vehicles with tyre pressure control system, set the new load conditions when necessary → page 231.

WARNING

Objects that are not secured, or are secured incorrectly, can cause serious injuries in the event of a sudden driving or braking manoeuvre or accident. This applies particularly if objects are struck by the airbag when activated and then flung through the vehicle interior. Please apply the following rules to reduce the risk of accidents:

- Always stow all objects in the vehicle securely. Always stow luggage and heavy objects in the luggage compartment.
- Always use suitable straps to prevent luggage from entering the deployment zones of the side airbag or the front airbag in the event of a sudden driving or braking manoeuvre or an accident.

- Objects should be stowed in the vehicle interior in such a way that they can never enter the airbag deployment zones while the vehicle is in motion.
- Always keep stowage compartments closed while driving.
- Stowed objects must never cause passengers to assume an incorrect sitting position.
- Any seat blocked by stowed objects must not be used by any passengers.



WARNING

The vehicle handling and braking effect may alter significantly if large or heavy objects are being transported.

- Adapt your speed and driving style to suit visibility, weather, road and traffic conditions.
- Accelerate carefully and gently.
- Avoid sudden braking and driving manoeuvres.
- Brake earlier than in normal driving.



NOTICE

Hard objects on the shelf can chafe against the wires of the heating element in the rear window and cause damages.

 Observe any information concerning towing loading → page 184, *Towing a trailer*. 

Luggage compartment

Introduction

Heavy objects must always be stowed securely in the luggage compartment and you must ensure that the rear seat backrests are securely engaged in the upright position. Always use suitable securing straps. Never overload the vehicle. Both the payload and the distribution of the load in the vehicle affect driving response and braking distance →  

⚠ WARNING

When the vehicle is not in use, always lock the doors and boot lid to reduce the risk of severe or fatal injuries.

- Never leave children unattended in the vehicle, especially when the boot lid is open. Children could climb into the luggage compartment and shut the boot lid. In these situations, children would not be able to leave the luggage compartment by themselves. This could lead to severe or fatal injuries.
- Never let children play in or around the vehicle.
- Never travel in the luggage compartment.

⚠ WARNING

Objects that are not secured, or are secured incorrectly, can cause serious injuries in the event of a sudden driving or braking manoeuvre or accident. This applies particularly if objects are struck by the airbag when activated and then flung through the vehicle interior. Please apply the following rules to reduce the risk of accidents:

- Do not stow any hard, heavy or sharp objects loose in any of the vehicle's open stowage areas, on the boot lid or on the dashboard.
- Remove any hard, heavy or sharp objects from items of clothing and bags inside the vehicle and stow them securely.

⚠ WARNING

Transporting heavy objects changes the vehicle's handling and increases the braking distance. Heavy loads that are not properly stowed or secured in the vehicle can lead to a loss of vehicle control and can cause serious injuries.

- Transporting heavy objects changes the vehicle's handling and the centre of gravity.
- Always secure heavy objects as far back into the luggage compartment as possible.

ℹ NOTICE

Hard objects could chafe against the wires of the heating element in the rear window and cause damage.

i The ventilation openings between the rear window and the luggage compartment cover must not be covered as this would prevent stale air escaping from the vehicle.

Luggage compartment cover

📖 Please refer to **⚠** and **ℹ** at the start of the chapter on page 179.



Fig. 151 In the luggage compartment: remove and install the luggage compartment cover.

When the rear lid is opened and closed, the cover is automatically raised or lowered when the retention cords are attached.

The luggage compartment cover can be used to stow light garments. Ensure rear visibility is not impaired

Removing the luggage compartment cover

- Unfasten the retaining cords from the rear lid support → **Fig. 151** (upper arrows).
- Remove the luggage compartment cover from behind out of the side supports → **Fig. 151** (lower arrows).

Install the luggage compartment cover

- Push the luggage compartment cover forward, engaging the side supports → **Fig. 151** (lower arrows).
- Fit the retaining cords on the rear lid → **Fig. 151** (upper arrows).

⚠ WARNING

Loose objects or that are not correctly secured, as well as animals on top of the luggage compartment cover can cause serious injuries in the event of a sudden driving or braking manoeuvre or accident.

- Do not stow any hard, heavy or sharp objects in pockets, purses or loose on the surface of the luggage compartment cover.

- Never carry animals on top of the luggage compartment cover.
- Never drive with the luggage compartment cover raised. Double down or remove the cover prior driving.

⚠ NOTICE

To prevent damages to the luggage compartment cover:

- Always make sure the luggage compartment cover is firmly secured to the side supports.
- Only load the luggage compartment upward so that the luggage compartment cover is not pressed against the luggage when the rear lid is closed.

Variable luggage compartment floor

📖 Please refer to ⚠ and ⚠ at the start of the chapter on page 179.

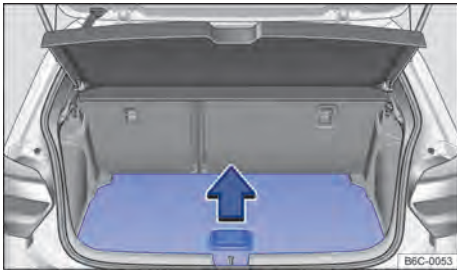

Fig. 152 In the luggage compartment: raise the luggage compartment floor.

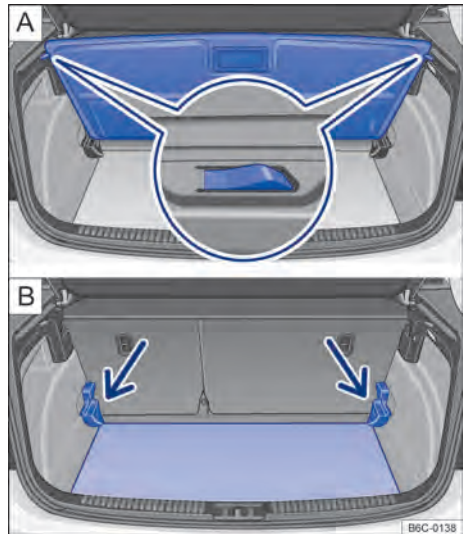

Fig. 153 In the luggage compartment: adjust the luggage compartment floor height.

Depending on the vehicle version, the variable luggage compartment floor may not be available.

Open and close the luggage compartment variable floor

To *open*, lift by the handle → Fig. 152 in the direction indicated by the arrow and fold the luggage compartment floor fully upwards.

To *close*, fold the luggage compartment floor downwards.

Adjusting the variable luggage compartment floor

- Lift the luggage compartment floor cover and pull it back removing it from the luggage compartment side guides → Fig. 153 [A].
- Insert the luggage compartment floor into the side guides of the desired height and pull forward up to the striker.

Unfold the luggage compartment downwards

- Lift the luggage compartment floor and push down underneath the guide → Fig. 153 [B] (arrows).
- Place the luggage compartment floor over the floor lining.
- Fold the rear seat back rests forward if necessary → page 76.

NOTICE

When closing, always slowly move the luggage compartment floor downwards. Otherwise, the luggage compartment floor or lining could be damaged.

Luggage net



Please refer to  and  at the start of the chapter on page 179.



Fig. 154 On the luggage compartment: luggage net.

According to the vehicle version, the luggage net may not be available.

The luggage net stops light items of luggage from sliding around the luggage compartment.

Fitting the net in the luggage compartment

Hook the luggage net hooks → [Fig. 154](#) into the fastening rings available in the luggage compartment.

Removing the luggage net

A fitted luggage net is held under tension. → .

- Remove the luggage net hooks from the fastening rings.
- Stow the luggage net in the luggage compartment

WARNING

The elastic luggage net must be stretched when it is secured to the fastening rings in the luggage compartment. A fitted luggage net is



held under tension. The luggage net hooks can cause injuries if the luggage net is installed or removed incorrectly.

- Always hold the luggage net hooks tightly to prevent them from falling out of the ring during installation or removal.
- Protect your eyes and face to avoid injuries from any hooks that may spring out during installation or removal.
- Always attach the luggage net hooks in the order described. If one of the hooks snaps back, the risk of injury increases.

NOTICE

The luggage net must be used to store small and light objects of up to 5 kg.

Bag hooks

Please refer to  and  at the start of the chapter on page 179.

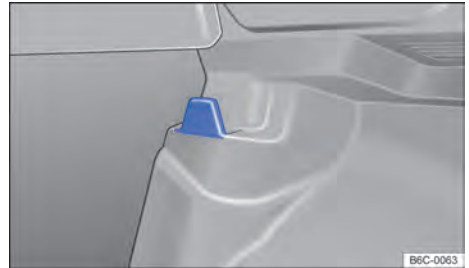

Fig. 155 On the luggage compartment: bag hooks.

Bag hooks may be available in the upper left and right-hand sides of the luggage compartment → [Fig. 155](#).

WARNING

Never use the bag hooks for securing purposes. The bag hook could break off during a sudden braking manoeuvre or accident.

NOTICE

Each bag hook supports a maximum load of 2.5 kg.

Roof carrier

Introduction

The vehicle's roof was designed to optimize aerodynamics. Conventional roof carrier systems may no longer be fastened in rain gutters.

Once rain gutters are modelled into the roof to facilitate water drainage, only roof carriers authorized by Volkswagen may be used.



WARNING

When transporting heavy or large objects in the roof carrier, vehicle driving conditions are altered due to the shift of the gravity centre and increased wind resistance surface.

- Always secure loads properly using suitable and undamaged securing straps or tension belts.
- Heavy, large, long or flat loads negatively affect the vehicle's aerodynamics, centre of gravity and driving behaviour.
- Avoid abrupt and sudden braking and driving manoeuvres.
- Adapt your speed and driving style to suit visibility, weather, road and traffic conditions.

 Remove the roof rack when it is not being used, preventing unnecessary fuel consumption due to greater aerodynamic resistance. <

Fastening roof carrier base supports

 Please refer to  at the start of the chapter on page 182.

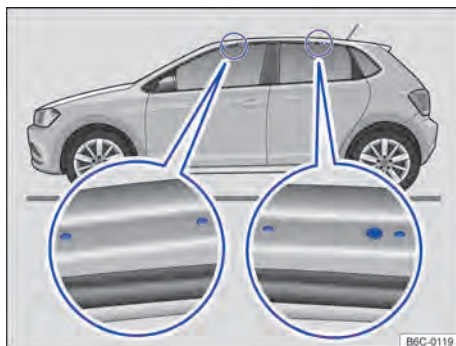

Fig. 156 Fastening points in roof carrier base supports (both sides).

Roof carriers are the base for a complete load transportation system. For safety reasons, exclusive additional supports are required when transporting luggage, bicycles, surf boards, skiing equipment, and boats. Additional accessories can be acquired at Volkswagen Dealerships.

The roof carrier base supports must always be properly fastened. Always follow the instructions in the respective owner's manual.

Fastening roof carrier base supports

The holes or markings of fastening points in base supports are clearly visible upon opening the vehicles front and rear doors, located next to the roof pillars → Fig. 156 (magnifying glass). The rear fastening holes or markings are located below the roof pillars → Fig. 156 (right-hand side magnifying glass).

Holes and markings can only be seen with open doors.

Only fasten base supports to the markings illustrated in the figure → .

WARNING

Improperly fastening base supports and roof rack, as well as its incorrect use, may cause the entire system to detach from the roof, resulting in injuries and accidents. ►

- Always follow the instructions provided in the owner's manual.
- Only use roof carriers when base supports are properly fastened and the roof carrier presents proper use conditions.
- Only fasten base supports to the markings illustrated in the figure → Fig. 156.
- Assemble roof carrier base supports correctly.
- Check bolts and fastening points before driving and re-tighten them after short drives. In case of long hauls, check the bolt and fastening spots upon each stop.
- Always assemble special roof carriers for bicycles, skiing equipment, surf boards, etc. correctly.
- Do not modify or repair roof carriers and base supports.

NOTICE

Always observe roof carrier manufacturer's installation instructions.

- Keep roof carrier manufacturer's installation and use instructions along with the vehicle wallet.

NOTICE



Damages caused by improper roof carrier fastening are not covered by the warranty.

- The vehicle level is altered after assembling a roof carrier and stowing loads. Compare the vehicle level with available passage heights, for example, in road bridges and garage doors.

 Read and follow installation instructions provided along with the roof carrier, always keeping such instructions in the vehicle.

 It is paramount to know applicable laws regarding the sizes of volumes transported over vehicle roofs.

Loading the roof carrier

 Please refer to  at the start of the chapter on page 182.

Loads may only be safely fastened when the roof carrier system is properly assembled → .

Maximum roof weight permitted

The maximum roof weight permitted is **45 kg**. The roof load encompasses the weight of the roof carrier and the load to be transported over the roof → .

Always mind the weight of the roof carrier and load to be transported. Never exceed the maximum roof load permitted.

When using roof carriers with lower load capacities, the maximum roof load permitted may not be used. In this case, the roof carrier may only be loaded until the weight limit indicated in its installation instructions.

Distributing load

Distribute the load evenly and ensure proper protection → .

Controlling fastening points

After the base supports and roof carrier have been fastened, bolt and fastening points must be checked after short hauls and in regular intervals during long hauls.

WARNING

Accidents and severe injuries can occur if the maximum permitted roof weight is exceeded.

- Never exceed the maximum roof weight permitted, maximum axle weight permitted and the total vehicle weight permitted.
- Never exceed the roof carrier load capacity, even if under the maximum roof load capacity.
- Fasten heavy objects as far ahead as possible and uniformly distribute the load.

WARNING



Loose or incorrectly fastened loads may fall from the roof carrier and cause accidents and injuries.

- Always secure loads properly using suitable and undamaged securing straps or tension belts.
- Properly fasten loads.

 At times, unused roof carriers are left assembled on the roof. Due to the greater aerodynamic resistance, the vehicle will unnecessarily consume more fuel. Therefore, remove roof carriers when they are not being used. ▶

 The load transported on the roof must be properly fastened. Transporting loads on the roof changes the vehicle's behaviour.

Usage guidelines

 Please refer to  at the start of the chapter on page 182.

When to remove the roof carrier:

- When it is no longer necessary.
- When the vehicle passes through an auto-wash system.
- When the vehicle level exceeds the maximum passage height in a garage, for example.

NOTICE

- Remove the roof carrier before submitting the vehicle into an auto-wash system.
- The vehicle level is altered after assembling a roof carrier and stowing loads. Compare the vehicle level with available passage heights, for example, in road bridges and garage doors.
- The roof aerial and boot lid cannot be affected by the roof carrier system or loads secured to the roof.
- Ensure that the boot lid does not come into contact with roof carrier loads upon opening.

Towing a trailer

Introduction

Observe any country-specific regulations when towing a trailer and using a towing bracket.

Your car is intended mainly for transporting passengers and luggage. However, it can also be used to tow a trailer or caravan, provided that it is fitted with the appropriate technical equipment. This additional maximum trailer weight will affect the durability, fuel consumption and performance of the vehicle and, in certain circumstances, can shorten the service intervals.

Driving with a trailer not only places an extra load on the vehicle, but also requires increased concentration on the part of the driver.

Vehicles with Start-Stop system

Before towing a trailer, the Start-Stop system must be manually disabled and remain disabled at all times while towing a trailer → page 108.

DANGER

It is dangerous to transport people in a trailer and it may also be illegal.

WARNING

Improper use of the towing bracket can cause injury and accidents.

- Only use the towing bracket if it is fitted properly and is not damaged.
- Do not perform any modifications or repairs to the towing bracket.

WARNING

Towing a trailer and transporting heavy or bulky items can change the way the vehicle's handling and cause accidents.

- Therefore, observing the instructions below is essential to ensure the safety of the driver, passengers, and other road users.
 - Always secure loads properly using suitable and undamaged securing straps.
 - Adapt your speed and driving style to suit visibility, weather, road and traffic conditions.
 - Trailers with a high centre of gravity are more likely to tip over than trailers with a low centre of gravity.
 - Avoid abrupt and sudden braking and driving manoeuvres.
 - Take special care when overtaking.
 - Reduce your speed immediately if the trailer shows even the slightest sign of snaking.
 - When towing a trailer do not drive faster than 80 km/h (50 mph). This also applies to countries where higher speeds are permitted. Always obey speed limits. In some areas speed limits for vehicles towing trailers are lower than for vehicles without trailers.
 - Never try to “stop” a trailer from snaking by increasing your speed.

WARNING

With a retrofitted towing bracket, the Start-Stop system must always be manually turned off when towing a trailer. Otherwise, this may cause damages to the brake system and result in severe accidents and injuries.

 In new vehicles, do not tow a trailer during the first 1,000 km → page 184.

Technical requirements

 Please refer to  and  at the start of the chapter on page 184.

Only use a towing bracket which is approved for the gross weight of the trailer you wish to tow. The towing bracket must be suitable for your vehicle and trailer and must be securely bolted to the vehicle's chassis. Always check and follow the data provided by the towing bracket manufacturer.

Towing brackets fitted to the rear bumper

Never fit a towing bracket to the rear bumper or to its fastening. A towing bracket must not prevent the rear bumper from functioning correctly. Do not carry out any alterations to the exhaust or brake systems. Check regularly to see if the towing bracket is fitted securely.

Engine cooling system

There is an increased load on the engine and the cooling system when towing a trailer. The cooling system must contain sufficient coolant and be able to cope with the extra load added by the trailer.

Trailer brake

If the trailer is equipped with its own brake system, observe any legal requirements. The trailer's brake system must never be connected to the vehicle brake system.

Emergency breakaway cable

Always use the emergency breakaway cable between your vehicle and the trailer → page 185.

Rear trailer lights

The rear lights on the trailer must meet legal requirements → page 185.

Never connect the trailer lights directly to the electrical system of your vehicle. If you are uncertain whether the trailer has been connected correctly, please contact a qualified workshop. Volkswagen recommends using a Volkswagen Dealership for this purpose.

Exterior mirrors



 you are unable to see the traffic behind the trailer in the vehicle's standard exterior mirrors, additional exterior mirrors should be fitted in accordance with any country-specific regulations. Before setting off, adjust the mirrors so that you have a sufficient view of the rear.

WARNING



If the towing bracket is unsuitable or incorrectly fitted, the trailer can become detached from the vehicle and cause severe injuries.

NOTICE

- The vehicle electronics may be damaged if the trailer lights are not connected properly.
- The vehicle electronics may be damaged if the trailer uses too much electricity.
- Never connect the trailer's electrical system directly to the electrical connections of the tail lights or to other sources of electricity. Use only suitable connectors to supply power to the trailer.

 Volkswagen recommends additional services between the normal inspection intervals if the vehicle is used frequently for towing a trailer. 

Engaging and connecting the trailer

 Please refer to  and  at the start of the chapter on page 184.

Emergency breakaway cable

Always fasten the emergency breakaway cable properly in the towing vehicle. In this case, leave some slack for the breakaway cable to allow curves. However, the breakaway cable must not drag on the ground while driving. 

Rear trailer lights

Ensure that the rear trailer lights are functioning properly and are in compliance with legal requirements.

WARNING

Unsuitable or incorrectly connected electrical conductors may power the trailer, cause operating faults in the vehicle's electronics and cause severe injuries.

- All activities regarding the electrical system can only be conducted by a Volkswagen Dealership or qualified workshop.
- Never connect the trailer's electrical system directly to the electrical connections of the tail lights or to other sources of electricity.

NOTICE

A trailer parked over the support wheel or over the trailer supports must not be connected to the vehicle. For example, the vehicle is lifted or lowered due to load changes or tyre damages. In this case, major forces act over the trailer bracket and over the trailer, which may damage the vehicle and the trailer.

 If the engine is not running and electrical equipment is switched on in the trailer via the trailer socket, the vehicle battery will discharge.

Loading the trailer

 Please refer to  and  at the start of the chapter on page 184.

Maximum trailer weight and drawbar load

The maximum trailer weight is the weight that the vehicle can pull. The drawbar load is the weight that the towing bracket exerts vertically on the ball coupling.

The figures for maximum trailer weight and drawbar weights that are given on the data plate of the towing bracket are for certification purposes only. The correct values for your specific model, which may be *lower* than these figures, are provided in the vehicle registration documents. All data in the official vehicle documents take precedence over this data.

In the interest of road safety, Volkswagen recommends that you always transport the maximum **drawbar load**. The response of the trailer on the road will be poor if the drawbar load is too small.

The drawbar load increases the weight on the rear axle and reduces the maximum load level as a result.

Gross combination weight

The gross combination weight is comprised of actual loaded vehicle and loaded trailer weights.

Loading the trailer

The weight of the load should be distributed evenly. The maximum permitted drawbar load should be utilised. Do not place the load only at the front or the rear of the trailer:

- Distribute loads in the trailer so that heavy objects are either over or as near to the axle as possible.
- Secure all loads on the trailer properly.

Tyre pressure

Follow the trailer manufacturer's recommendations concerning the tyre pressure for the trailer tyres.

When towing a trailer, inflate the wheels on the towing vehicle with the maximum permitted tyre pressure → page 233.

WARNING

Accidents and serious injuries can occur if you exceed the vehicle's maximum permitted gross axle weight rating, drawbar load, gross vehicle weight rating or gross combination weight rating.

- Never exceed the specified values.
- Never let the actual weights at the front and rear axles exceed the gross axle weight ratings. Never exceed the permissible gross vehicle weight for the vehicle with weight at the front and rear of the vehicle.

WARNING

Moving loads can severely impair the vehicle's stability and driving safety, which can cause accidents and severe injuries.

- Always load trailers correctly.
- Always secure loads properly using suitable and undamaged securing straps.

Towing a trailer

 Please refer to  and  at the start of the chapter on page 184.

Headlight adjustment

Towing a trailer can raise the front end of the vehicle enough for the dipped beam to blind other road users. The headlights must be adjusted in a Volkswagen Dealership or qualified workshop.

Things to note when driving with a trailer

- If the trailer has an **overrun brake**, apply the brakes *gently at first*, and then firmly. This will prevent the jerking that can be caused by the trailer wheels locking.
- The gross combination weight causes the braking distance to increase.
- Prior taking on strong downhill slopes, select a lower gear (manual gearbox or Tiptronic mode of the automatic gearbox) to make use of the engine as a brake. The brake system could otherwise overheat and fail.
- The vehicle's centre of gravity and the vehicle's handling will change because of the maximum trailer weight and the increased combined towing weight of the vehicle and trailer.
- The weight distribution of a loaded trailer with an unladen towing vehicle is very unfavourable. When driving in this situation, drive particularly carefully and slowly.

Pulling off on hills when towing a trailer

Depending on the steepness of the slope and the total weight of the trailer and vehicle, a parked vehicle towing a trailer could roll back a short distance when moving off on a hill.

When towing a trailer, pull off on hills as follows:

- Press and hold the brake pedal.
- Pull the handbrake.
- *Vehicles with manual gearbox*: press the clutch pedal fully down.
- Engage the 1st gear → page 110 or the D/S selector lever position → page 111.
- Release the brake pedal.
- Pull away slowly. With manual gearbox, gently release the clutch pedal.
- Only let go of the handbrake lever when the engine has sufficient power to move off.

WARNING

Incorrect trailer towing can cause loss of vehicle control and severe personal injuries.

- Towing a trailer and transporting heavy or bulky items can change the way the vehicle's handling and increase the braking distance.
- Always drive carefully and defensively. Brake earlier than in normal driving.
- Adapt your speed and driving style to suit visibility, weather, road and traffic conditions. Reduce your speed, especially when going downhill.
- Accelerate carefully and gently. Avoid abrupt and sudden braking and driving manoeuvres.
- Take special care when overtaking. Reduce your speed immediately if the trailer shows even the slightest sign of snaking.
- Never try to “stop” a trailer from snaking by increasing your speed.
- In some areas speed limits for vehicles towing trailers are lower than for vehicles without trailers.

Retrofitting a towing bracket

📖 Please refer to ⚠ and ⚠ at the start of the chapter on page 184.

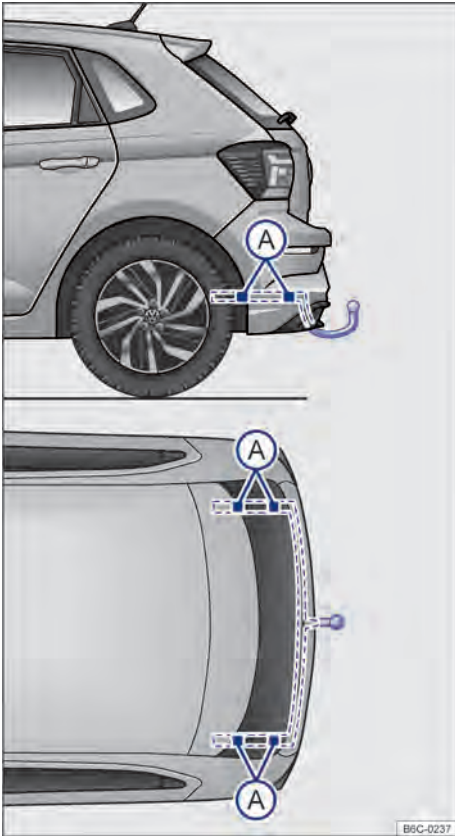

Fig. 157 Attachment points for retrofitting a towing bracket.

Figure → Fig. 157 illustrates as an example the fastening point to install a towing bracket on the Polo model.

Towing bracket retrofitting must be executed in accordance with the instructions provided by the bracket's manufacturer, always considering the attachment points indicated in → Fig. 157 (A).

The towing bracket securing points can be seen from the lower part of the vehicle. The towing bracket must be secured to such points.

Retrofitting a towing bracket

- Observe applicable laws in the country in which the vehicle will run.
- It might be necessary to disassemble and reassemble the rear bumper. Additionally, it is also necessary to tighten the towing bracket screws with a torque meter and connect a socket to the vehicle's electrical system. For such, special tools and expertise are required.
- The figure indicates securing points that must be observed when installing towing brackets.

⚠ WARNING

Unsuitable or incorrectly connected electrical conductors may cause operating faults in all of the vehicle's electronic components, which may cause severe accidents and injuries.

- Never connect the trailer's electrical system directly to the electrical connections of the tail lights or to other improper sources of electricity. Use only suitable connectors for trailer connection.
- Retrofitting of a towing device must be carried out by an authorized Volkswagen dealership.

⚠ WARNING

If the towing bracket is unsuitable or incorrectly fitted, the trailer can become detached from the vehicle. This could lead to severe accidents and fatal injuries.

ⓘ NOTICE

Towing a trailer represents a greater stress for the vehicle. Before deciding to **retrofit**, contact a Volkswagen Dealership to know if it is necessary to perform any modifications in the cooling system or if thermal shielding plates must be installed.

Fuel

Fuel handling safety guidelines

WARNING

Filling the tank incorrectly and improper handling of fuel can cause explosions, fire and serious burns and injuries.

- Always ensure that the tank cap is closed properly to prevent the evaporation and spillage of fuel.
- Fuel is highly explosive and inflammable and can cause serious burns and other injuries.
- Fuel can spill out if the engine is not switched off or the filler nozzle is not fully inserted into the fuel filler neck when filling the tank. This may cause fires, explosions and serious burns and injuries.
- When filling the tank with fuel, the engine and the ignition must be switched off for safety reasons.
- When filling the tank, always switch off your mobile telephone and two-way radio or any other radio equipment. Electromagnetic radiation can generate sparks which can in turn start a fire.
- When filling the tank, never get into the vehicle. If in exceptional cases you have to enter the vehicle, close the door and touch a metal object before touching the filler nozzle again. This will remove any spark-generating electrostatic charges from you. Sparks can cause a fire when filling the tank.
- Never fill the tank or fill up a spare canister near open flames, sparks or glowing items (e.g. cigarettes).
- Electrostatic discharge and electromagnetic radiation must be avoided when filling the tank.
- Follow all applicable safety information provided by the filling station when filling the tank.
- Never spill fuel in the vehicle or in the luggage compartment.

WARNING

For safety reasons, Volkswagen does not recommend carrying a spare fuel canister in the vehicle. Fuel can spill out of the full or empty canister and catch fire, especially in the event of an accident. This could cause explosions, fire and injuries.

- If, in exceptional circumstances, you have to transport a spare fuel canister, please note the following:
 - When refilling, never place the canister in or on top of the vehicle (e.g. in the luggage compartment). There may be an electrostatic charge during refilling causing the fuel fumes to ignite.
 - Always place the spare fuel canister on the ground.
 - When filling a spare fuel canister, place the filler nozzle as far as possible into the filler opening.
 - If the spare fuel canister is made of metal, the filler nozzle must have constant contact with the canister in order to avoid static charging.
 - Please follow all legislation concerning the use, stowage and transportation of spare fuel canisters.

NOTICE

- Remove spilt fuel from the vehicle paint as quickly as possible in order to avoid damage to the wheel housing, tyres and vehicle paint.
- Do not run the tank empty. Irregular filling periods can cause backfiring and allow unburnt fuel to enter the exhaust system. This could damage the catalytic converter. 

Fuelling and fuel types

Introduction

The fuel cap is located at the rear right-hand side of the vehicle.

The factory-fitted sticker on the inside of the tank flap indicates the required fuel type for the vehicle. 

WARNING

Incorrect handling of fuel may cause explosions, fire and severe burns and injuries.

- Fuel is highly explosive and inflammable.
- Never handle fuel near open flames, sparks or glowing items (e.g. lighters).
- Observe any valid safety information and legislation concerning the handling of fuels.

NOTICE



- If the TOTALFLEX vehicle is immobilized by "lack of fuel", the vehicle must be refilled with the last type of fuel used - petrol or ethanol.
- If it is necessary to fill the tank with a different type of fuel, the following may occur:
 - Considerable decrease in engine performance.
- The vehicle must run for approximately 5 kilometres to recognize the new fuel type, in order to prevent any of the scenarios above.

NOTICE

For vehicles with TSI engines: if there is an option to refuel the vehicle exclusively with Ethanol-type fuel, it is recommended that every 10,000 km the vehicle be refueled with at least one full tank of gasoline. This recommendation is mandatory to observe, and aims to prevent the accumulation of contaminating matter arising from the characteristics of Ethanol. This possible accumulation of contaminating matter in the fuel supply system can result in loss of engine performance or even difficulties in starting the vehicle.

 When the airbags are triggered during an accident, the fuel supply is interrupted → page 45, *In case of airbag triggering - Crash detection function.*

Petrol engine

 Please refer to  and  at the start of the chapter on page 190.

Vehicles with a petrol engine must be driven using **unleaded petrol free from any metallic additives (such as manganese)**, in accordance with applicable country laws.



Petrol additives

The quality of petrol influences the running properties, performance and service life of the engine. Therefore, fuel up with quality fuel and, when necessary, use the adequate additives.



The use of unsuitable petrol additives can cause considerable damage to the engine and catalytic converter. Metallic petrol additives should be avoided at all times.

NOTICE

If, in an emergency, you have to use a different from specified petrol, drive at medium engine speeds and avoid high engine loading. Avoid high engine speeds and heavy engine loads. Failure to do so can result in engine damage! Fill the tank with the recommended petrol as soon as possible.

 Just one tank full of leaded fuel, or fuel containing other metallic additives (such as manganese), can seriously impair the efficiency and cause damages to the catalytic converter. 

TOTALFLEX engine

 Please refer to  and  at the start of the chapter on page 190.

Petrol

Vehicles must be driven using **unleaded petrol free from any metallic additives (such as manganese)**, with RON 95/E24 (blue) ethanol percentage.

Petrol additives

The quality of petrol influences the running properties, performance and service life of the engine. Therefore, fuel up with quality fuel and, when necessary, use the adequate additives. 

The use of unsuitable petrol additives can cause considerable damage to the engine and catalytic converter. Metallic petrol additives should be avoided at all times.

Ethanol

The vehicle must be fuelled exclusively with **hydrated ethanol**, in accordance with applicable country laws. 

NOTICE

- The use of unsuitable petrol additives can cause considerable damage to the engine and catalytic converter.
- If, in an emergency, you have to use fuel different than specified, drive at medium engine speeds and avoid high engine loading. Avoid high engine speeds and heavy engine loads. Failure to do so can result in engine damage! Fill the tank with the recommended petrol as soon as possible.
- Just one tank full of leaded fuel, or fuel containing other metallic additives (such as manganese), can seriously impair the efficiency and cause considerable damages to the catalytic converter.

Fuelling

📖 Please refer to ▲ and ⌚ at the start of the chapter on page 190.

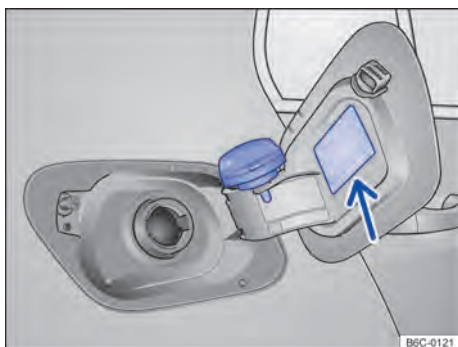

Fig. 158 Open tank flap with tank cap attached to the holder.

Switch off the engine, ignition and the mobile telephones **before** filling the tank and leave them switched off during the process.

Vehicles with TOTALFLEX engine were designed to use **both petrol and ethanol in any amount**.

Check the fuel tank capacity in → page 273.

Opening the tank flap

- Unlock the vehicle with the vehicle key or press the central locking button (🔒) in the driver door to unlock the vehicle from the inside → page 63.
- On the aft part of the tank flap, press and open the flap outward.
- Remove the tank cap rotating it counter clockwise and stow it into the holder on the tank flap → Fig. 158.

Filling the tank

The correct fuel grade for your vehicle is shown on a sticker on the inside of the tank flap → page 189.

- ◀ – The fuel tank is *full* when the filler nozzle clicks off for the first time → ▲.
- Do not continue filling the tank after it switches off! The expansion space in the fuel tank will otherwise fill up and the fuel could spill out. This could also happen when the fuel warms up and expands.

Closing the tank cap

- Turn the tank cap clockwise into the fuel filler neck until you hear it engage.
- Close the tank flap. The tank flap must be flush with the vehicle bodywork.

WARNING

Do not continue filling the tank once the filler nozzle stops automatically. The fuel tank cannot be overfilled. This can cause fuel to splash out and overflow. This could cause explosions, fires and severe injuries.

🌿 After the fuel filler nozzle is automatically switched off for the first time, the tank will have reached its capacity. Do not force fuel filling, since fuel may overflow.

- When filling, fuel may be spilt on the ground, polluting the environment. Always fill the at authorized filling stations with proper fluid collection and disposal systems. ▶

Engine control unit and exhaust gas emission control system

Introduction

The relevant components for the exhaust emission system reduce the emission of harmful elements:

- Engine Electronic Power Control (EPC) → page 192
- Catalytic converter → page 192
- Lambda probe → page 193
- Activated charcoal filter - supply system → page 193

Information regarding warning and indicator lamps is available in the Troubleshooting section at the end of the chapter → page 193.

WARNING

Combustion engine combustion gases contain carbon monoxide which can provoke fainting and lead to death.

- Never start or run the engine in unventilated or closed spaces.
- Never leave the engine running if you leave the vehicle unattended.

WARNING

The exhaust system components become very hot. This may cause fires.

- Park the vehicle so that no part of the exhaust system can come into contact with any inflammable material underneath the vehicle, e.g. dry grass.
- Never apply underseal or anti-corrosion coatings to the exhaust pipes, catalytic converter, diesel particulate filter or the heat shields on the exhaust system.

Electronic engine power control (EPC)

Please refer to  at the start of the chapter on page 192.

The electronic engine power control (EPC) is a system designed to determine the throttle valve position based on the torque required by the driver through the electronic pedal (e-gas system); the indicator lamp **EPC** lights up in the event of system malfunctions.

Under normal operating conditions, when the driver activates the accelerator pedal, the system transforms such request into a need for speed and power.

By controlling engine components (sensors and actuators), the best performance possible is calculated, based on the driver's request. 

Catalytic converter

Please refer to  at the start of the chapter on page 192.

The catalytic converter is used for exhaust gas post-treatment and helps mitigate the emission of pollutants into the atmosphere. Observe the following points to ensure that the exhaust system and catalytic converter in the engine function properly for extended periods of time:

- Fill the tank only with unleaded petrol free from other metallic additives (such as manganese)
- Never allow the fuel tank to run completely dry.
- Never overfill engine oil → page 218.
- Never push and/or pull the vehicle to start the engine ("push starting"), but rather use the jump starting system → page 209.



If you notice misfiring, uneven running or loss of power when the vehicle is moving, reduce speed immediately. The vehicle should be inspected at the nearest Volkswagen Dealership or qualified workshop. If this happens, unburnt fuel can enter the exhaust system and escape into the atmosphere. The catalytic converter can also be damaged by overheating! 

NOTICE

Just one tank full of leaded fuel, or fuel containing other metallic additives (such as manganese), can seriously impair the efficiency and cause damages to the catalytic converter.

 Even when the exhaust purification system is working perfectly, there may be a smell of sulphur from the exhaust in some conditions. This depends on the sulphur content of the fuel being used. Often, it is simply a case of using a different fuel brand.



Lambda probe

 Please refer to  at the start of the chapter on page 192.

The purpose of the lambda probe is to monitor exhaust gases through a sensor hit by lead or other metallic additives (e.g. manganese) contained in the fuel, and gradually reduced. The lambda probe completely loses its efficiency after 10,000 km. The resulting lack of monitoring could cause engine malfunctions, such as:

- changes in driving conditions;
- hot engine starting problems;
- increased fuel consumption.



Activated charcoal filter - supply system

 Please refer to  at the start of the chapter on page 192.

The supply system has an activated charcoal system that accumulates hydrocarbons (steam) generated in the fuel tank (evaporative emission control), preventing such hydrocarbons from being released into the atmosphere. While the engine is running, these accumulated hydrocarbons are used in the normal engine combustion process.

 The activated charcoal filter prevents fuel tank gas hydrocarbons from being released into the atmosphere.

Troubleshooting

 Please refer to  at the start of the chapter on page 192.

If the engine operates irregularly or in case of engine jolts while driving, this could be related to insufficient fuel or low-quality fuel (e.g. water mixed in the fuel). In these cases, immediately slow down and seek assistance at a Volkswagen Dealership or qualified workshop nearby, driving at low revs and speed. If these symptoms occur immediately after filling the tank, switch the engine off immediately – as well as to avoid secondary damages – and seek assistance from a Volkswagen Dealership or qualified workshop.

Indicator lamps

The combustion gases emission control system (OBD) is not available in countries which legislation does not cover this system. In these cases the indicator lamp  will only light up when the ignition is turned on and when starting the engine.

EPC Engine management system fault (Electronic Power Control). **On:** the engine must immediately be checked at a Volkswagen Dealership.

 Faulty emissions in the exhaust system (OBD). **On:** slow down. Carefully drive to the nearest Volkswagen Dealership. The engine must be checked.

 **Flashing:** faulty catalytic converter. Reduce your speed. Carefully drive to the nearest Volkswagen Dealership. The engine must be checked.

When switching the ignition on, certain warning and indicator lamps flash to check functions. Such lamps go out after a few seconds.

WARNING

Failure to observe the warning lamps and text messages could lead to your vehicle breaking down in traffic, and to accidents and serious injuries.

- Never ignore any warning lamps or text messages that appear.
- Stop the vehicle as soon as possible and when safe to do so.

NOTICE

Failure to observe the illuminated indicator lamps and its descriptions and meanings could lead to vehicle damages.

If the indicator lamps  or **EPC** are lit up, fuel consumption may be higher and engine performance reduced.

Fuel quality

Considering the impracticality of supervising all filling stations, Volkswagen recommends filling the tank in stations included in the Distributor Network, which have clear programs, in order to ensure product quality.

Volkswagen Dealerships are prepared to handle engine sediments.

Fuel injection system

The vehicle is equipped with a fuel injection system that, under normal circumstances, waives the need for any periodical cleaning process, either with fuel additives or disassembling the injection valves to clean ultrasound systems.

Cleaning is required whenever damages or improper engine function occur due to use of low-quality fuel. In this case, Volkswagen recommends visiting a Volkswagen, Dealership, which has suitable additives and equipment.

NOTICE

Damages caused on the engine due to the use of improper or insufficient fuel are not covered by the warranty.

If and when Vehicle toolkit

Introduction

Observe any country-specific legislation when securing your vehicle in the event of a breakdown.

WARNING

In the event of a sudden driving or braking manoeuvre or accident, a loose vehicle toolkit and spare wheel could be flung through the vehicle and cause severe injuries.

- Always ensure that the vehicle toolkit or spare wheel are secured in the luggage compartment.

WARNING

Unsuitable or damaged tools in the vehicle toolkit can lead to accidents and injuries.

- Never work with unsuitable or damaged tools from the vehicle toolkit.

Vehicle toolkit stowage and access

Please refer to  at the start of the chapter on page 194.



Fig. 159 On the luggage compartment, under the floor lining: spare wheel and vehicle toolkit.

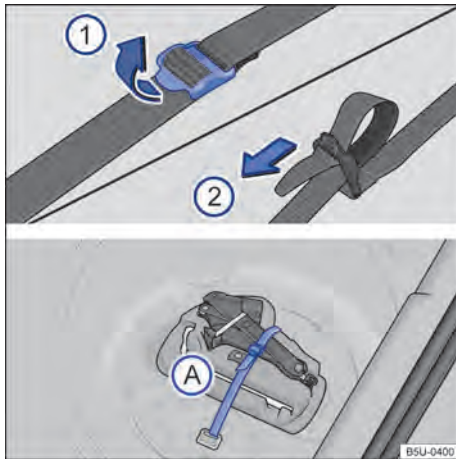

Fig. 160 On the luggage compartment: vehicle toolkit securing strap and vehicle toolkit.

The vehicle toolkit and spare wheel are located in the luggage compartment, under the floor covering → Fig. 159.

To access the vehicle toolkit, the spare wheel must be removed.

Accommodation of the vehicle toolkit

- If the case, lift and secure the variable luggage compartment floor → page 180.
- Lift the floor lining of the luggage compartment → Fig. 159.
- Remove the lining completely to remove the spare wheel and access the vehicle toolkit.

Release the vehicle toolkit securing strap

To release the securing strap → Fig. 160 (A), pull the buckle in the direction of the arrow ①.

Securing the vehicle toolkit

- Fit the vehicle toolkit in its housing.
- Pass the strap through the buckle in the direction of the arrow ② and firmly pull the belt to secure the vehicle toolkit.

i Always ensure that the spare wheel and vehicle toolkit are properly secured in the luggage compartment. <

Contents of the vehicle tool kit

o Please refer to **▲** at the start of the chapter on page 194.

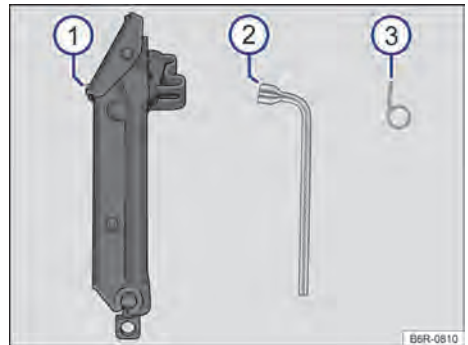

Fig. 161 Contents of the vehicle toolkit.

The content of the vehicle toolkit depends on the vehicle equipment level. The following describes the maximum scope.

Contents of the vehicle toolkit. → Fig. 161

- ① Jack. Before reinserting the jack back into the toolkit, close the jack with the box spanner until reaching the stop, in order to prevent noises while driving.
- ② Lug wrench. Also used as a jack lever to lift the vehicle → page 244.
- ③ Puller hook to remove the wheel bolt caps (when existing).

i Turn the jack back to its original position after use so it may be securely stored. <

Window wiper blades

Service position

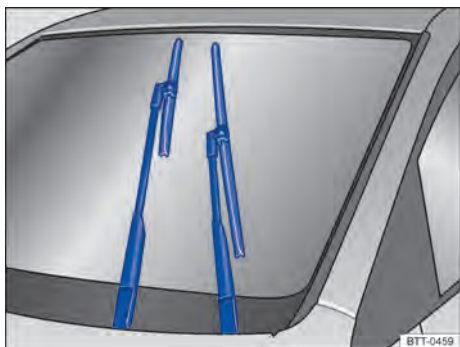

Fig. 162 Window wipers in service position.

In the service position, the windshield wiper arms can be lifted from the windshield. Proceed as follows to place the windshield wipers in service position → Fig. 162:

Activate the service position

- The bonnet must be closed → page 215.
- Switch the ignition on and off.
- Press the window wiper lever briefly downwards.

Suspending the windshield wiper arms off the windshield.

- Place the windshield wiper arms into service position before suspending them → ①.
- To suspend the windshield wiper arms, hold them **only** by the wiper blade attachment area.

Place the windshield wiper arms back on the windshield again prior driving! Press the windshield wipers lever briefly down with the ignition turned on, to return the windshield wiper arms back into the starting position.

⚠ NOTICE

- To avoid damages to the bonnet and window wiper arms, lift the windshield wiper arms only when in service position.
- Always ensure that the wiper arms are lowered onto the windshield prior driving. ◀

Cleaning and replacing window wiper blades

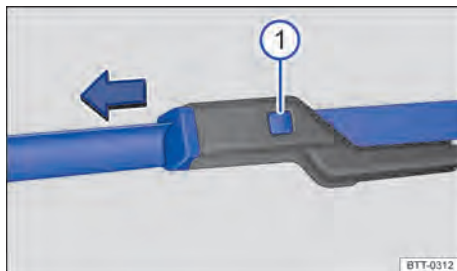

Fig. 163 Replacing windshield wiper blades.

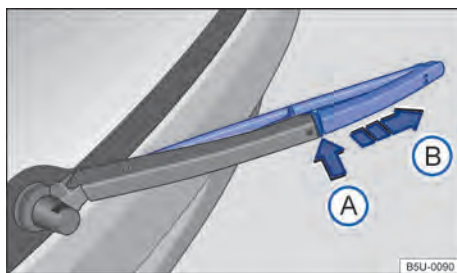

Fig. 164 Replacing the rear window wiper blades.

The factory-fitted window wiper blades are coated with graphite. The graphite coating ensures that the windshield wiper blade slides quietly over the windshield. A damaged graphite coating will among others, raise the noise level during the window wiping.

Check the condition of the window wiper blades on a regular basis. Replace the **window wiper blades** whenever they are dirty or are not performing properly → ①.

Damaged window wiper blades must be replaced immediately. Window wiper blades can be bought at Volkswagen Dealerships or qualified workshops.

Cleaning the windshield wiper blades

Observe on the windshield wipers: place the window wiper arms into service position before lifting them off the windshield → ①. ▶

- To suspend the windscreen wiper arms, hold them **only** by the wiper blade attachment area.
- Carefully clean the windscreen wiper blades with a damp sponge → ①.
- Fold the windscreen wiper arms carefully back onto the windscreen.

Replacing windscreen wiper blades

- Place the windscreen wiper arms into service position before suspending them → page 196.
- To suspend the windscreen wiper arms, hold them **only** by the wiper blade attachment area.
- Press and hold the release tab → Fig. 163 ① and pull off the windscreen wiper blade in the direction of the arrow.
- Insert the new wiper blade of the **same length and design** into the wiper arms until it is properly fitted.
- Fold the windscreen wiper arms carefully back onto the windscreen.

Replacing the rear window wiper blades

- Lift and fold the rear window wiper arm.
- Press and hold the release button → Fig. 164 ① pressed.
- Remove the rear window wiper blade in the direction of the arrow ②.
- Insert a new rear window wiper blade of the **same length and design** into the rear window wiper arms until it is properly fitted.
- Fold the rear window wiper arm carefully back onto the rear window.

⚠ WARNING

Worn or dirty window wiper blades reduce visibility and increase the risk of accidents and severe injuries.

- Replace window wiper blades whenever they are damaged or worn, and no longer appropriately perform their function.

📌 NOTICE

- Damaged or dirty window wiper blades may scratch the window.
- Detergents containing solvents, hard sponges and other sharp objects can damage the graphite coating during cleaning.
- Do not use fuel, nail varnish remover, paint thinner or similar products to clean the windows.

Exterior lighting

📖 Introduction

Before repairing the product, check which technology is used, incandescent lamp or LED. As rule of thumb, light bulbs can be replaced by yourself. When, according to the vehicle version, the exterior lighting is of LED technology, the replacement of the LED light unit or of the individual LEDs by yourself is not possible. The burning out of individual LEDs may be an indication of possible burn outs of other LEDs. In such case, the lights must be checked, and if necessary, replaced by a specialized workshop.

Changing the vehicle bulbs requires considerable technical skill. If you do not feel confident with the procedure, Volkswagen recommends that you have the bulbs changed by a Volkswagen Dealership or that you seek other expert assistance. Contact a qualified workshop if other vehicle parts around the lights need to be removed.

A box containing spare light bulbs for lights that are required to ensure that the vehicle is road-worthy should be stored in the vehicle at all times. Spare bulbs are available from Volkswagen Dealerships.

Driving with burned out exterior lighting devices may be illegal.

Additional bulb specifications

Some bulbs in headlights or tail lights might have factory specifications that are different than standard bulbs. The designation is inscribed on the bulb, either on the glass part or on the base.

LED technology in the vehicle

The components that use LED (Light Emitting Diode) have long service life and do not have to be changed frequently.

Volkswagen recommends that the replacement of components that use LED be done at a Volkswagen dealership.

Vehicle components that use LEDs are listed below:

- Headlights (*may not be available depending on the vehicle version*).
- Side turn indicator lamp: located in the exterior mirrors (*depending on the version of the vehicle this may not be available*)

- Brake light bulb: located externally on the boot lid, above the rear window.
- Daytime Driving Light: Located in the headlight (*depending on the vehicle version it may not be available*).
- Tail lights (*may not be available depending on the vehicle version*).

WARNING

Despite being illegal, driving with burnt bulbs may cause accidents. Burnt bulbs must be replaced as soon as possible.

- Insufficient lighting of roads, such as streets, avenues and squares, results in low visibility and increases the risk of accidents, since other road users might be unable to see vehicles running with burnt bulbs.

WARNING

Changing the bulb incorrectly can cause accidents and serious injuries.

- Before initiating any work in the engine compartment, always read and observe the warnings → page 213, *Safety guidelines for work in the engine compartment*. The engine compartment of any motor vehicle is a dangerous area and may cause severe injuries.
- Only change the defective bulb once it has had time to cool down completely.
- Never change a bulb unless you are familiar with the procedure. If you are uncertain of what to do, the work should be carried out by a Volkswagen Dealership or qualified workshop.
- Do not touch the glass part of the bulb with unprotected fingers. When the light is switched on, heat will cause fingerprints to evaporate on the bulb which will cause the reflector to "dim".
- There are sharp-edged parts in the headlight housing in the engine compartment and on the tail light cluster housing. Protect your hands when changing a bulb.

NOTICE

Damage to the electrical system can be caused if the rubber covers of the headlight housing are not properly mounted – especially due to water entering the system.

NOTICE



Volkswagen recommends special attention to some plastic parts with clamps, which might break when removing or fitting bulbs.

 Depending on the vehicle version, there may be two lighting reflectors in the rear bumper that are not equipped with bulbs. However, if these elements break and need to be replaced, visit a Volkswagen Dealership or qualified workshop.

 On cold and humid days the headlight lenses may become temporarily fogged because of the difference of temperature between the outside and the inside.

- With the headlight turned on, the outgoing light surface defogs in a short time, eventually leaving some residues at the borders.
- The tail lights and the turn signals may also be affected.
- The fogging phenomenon does not interfere with the life cycle of the lighting system of the vehicle. 

Information on changing bulbs

 Please refer to  and  at the start of the chapter on page 198.

Checklist

Always carry out the following actions for changing a bulb in the given order → :

1. Park the vehicle on a flat and solid surface at a safe distance from the flow of traffic.
2. Apply the handbrake → page 121.
3. Turn the light switch to position **0** → page 79.
4. Shift the turn signal lever to the neutral position → page 79.
5. Automatic gearbox: move the selector lever to position **P** → page 111.
6. Stop the engine and remove the key from the ignition cylinder → page 104.
7. Manual gearbox: select the gear → page 110.
8. Switch off the orientation lighting → page 79.
9. Let the defective bulb cool down.
10. Check to see if a fuse has blown → page 204. 

Checklist (Continued)

11. Change the faulty bulb as instructed → ⓘ; use a flashlight if necessary. Always use identical bulbs with the same designation. The designation is inscribed on the bulb, either on the glass part or on the base.
12. Do not touch the glass part of the bulb with unprotected fingers. The heat of the bulb would cause the fingerprint to evaporate and condense on the reflector, compromising the brightness of the headlight.
13. After changing the bulb, check to make sure that the bulb is working properly. If the bulb is not working properly, the bulb may not have been inserted properly or may have failed again, or the connector may have been inserted incorrectly.
14. Each time you change a bulb in the front of the vehicle, the headlight settings should be checked by a Volkswagen Dealership or qualified workshop.

⚠ WARNING

Ignoring any of the points on this important safety checklist can lead to accidents and injuries.

- Always follow the instructions on the checklist and comply with applicable safety precautions.

ⓘ NOTICE

Always take care when removing or fitting lights to prevent damage to the paintwork or to other vehicle parts.

 Burnt bulbs must not be disposed of as common trash, since they contain residues that are potentially harmful to the environment.

 In order to help preserve the environment, Volkswagen recommends returning burnt bulbs to a Volkswagen Dealership or qualified workshop, in order for them to be properly disposed of based on specific legal requirements regarding handling, storage and disposal.

Removing and installing the headlights

📖 Please refer to ⚠ and ⓘ at the start of the chapter on page 198.

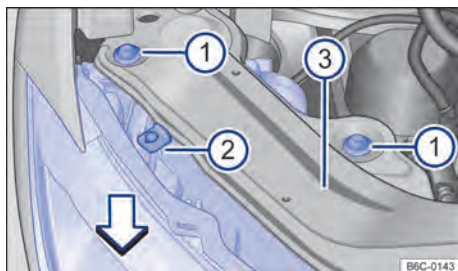

Fig. 165 In the engine compartment: fastening bolts of the headlights

The headlight must be removed to replace a bulb.

In the engine compartment, the headlights are covered by other vehicle parts. Volkswagen recommends changing bulbs at a Volkswagen Dealership in case of doubt.

Removing the headlight

- Turn the lights and the ignition off.
- Open the bonnet ⚠ → page 215.
- Remove the fastening bolts → Fig. 165 ⓘ with a torx wrench.
- Move the headlight forward, in the direction indicated by the arrow → Fig. 165 until the two retainers on the underside disengage and enable the removal of the headlight.
- Disconnect the supply connector, to completely remove the headlight → ⓘ.

Installing the headlight



- Carefully reinsert the headlight until the two retainers on the underside engage and the upper stopper → Fig. 165 ⓘ touches the headlight support ⓘ.
- Reconnect the supply connector.
- Reinstall the fastening bolts ⓘ in the headlight housing.
- Press the headlight against the centre upper striker ⓘ and tighten the bolts ⓘ with the torx screwdriver.
- Close the engine compartment and check the alignment of the headlight. ▶

NOTICE

- Ensure a correct positioning of the power supply connector to the headlight housing to prevent damages to the electric system caused by water penetration.
- Always take care when removing or fitting lights to prevent damage to the paintwork or to other vehicle parts.

The illustrations show the right-hand headlight. The left-hand headlight is a mirror image of the one shown.

Changing headlight bulbs (variant 1)

Please refer to  and  at the start of the chapter on page 198.

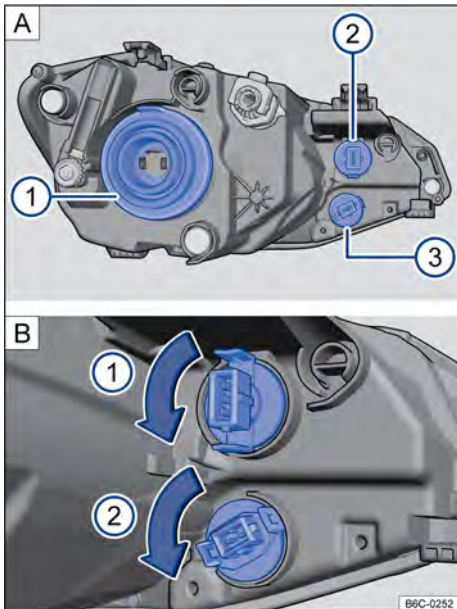

Fig. 166 In the engine compartment: headlight. ① Daytime running light and position light and ② Direction indicator.

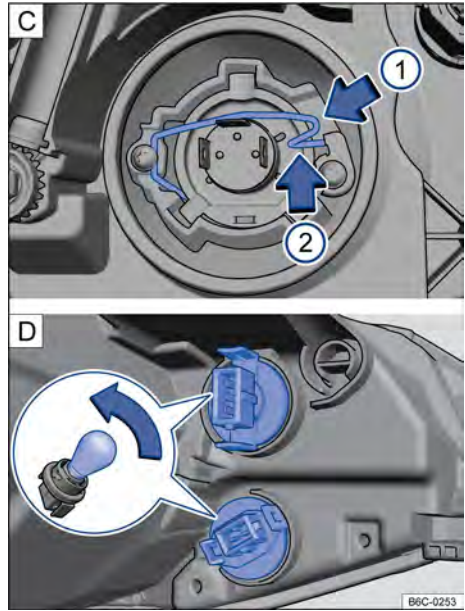



Fig. 167 In the engine compartment: high and low beam turn signal cover.

Depending on the vehicle version, changing the incandescent headlight bulbs may vary.

The headlight must be removed to replace a bulb → page 199.

In the engine compartment, the headlights are covered by other vehicle parts. Volkswagen recommends changing bulbs at a Volkswagen Dealership in case of doubt.

The actions should only be carried out in the specified order.

- ① Observe and follow the instructions on the checklist → page 198.
- ② Open the bonnet  → page 215.
- ③ Removing the headlight → page 199.
- ④ **Dipped beam and Main beam**, unplug the lamp power connector [A] ① at the rear of the lighthouse.

Daytime running light and Position light, unplug the lamp power connector [A] ② at the rear of the lighthouse.

Turn signal, unplug the lamp power connector [A] ③ at the rear of the lighthouse. ▶

- ⑤ **Dipped beam** and **Main beam**, remove the rubber cover **A** ①.

Daytime running light and **Position light**, turn the socket in the direction of the arrow **B** ① and remove socket.

Turn signal, turn the socket in the direction of the arrow **B** ② and remove socket.

- ⑥ **Dipped beam** and **Main beam**, press the spring downwards in the direction of the arrow **C** ① and move to the side in the direction of the arrow **C** ② and unhook it from the support.

- ⑦ **Dipped beam** and **main beam**, remove the defective bulb from its holder.

Daytime running light and **Position light**, turn the burnt out bulb counterclockwise as far as the stop **D** and remove the bulb from the socket.

Turn signal, turn the burnt out bulb counterclockwise as far as the stop **D** and remove the bulb from the socket.

- ⑧ **Dipped beam** and **Main beam**, replace the burnt-out halogen lamp with a new halogen lamp of the same model.

Daytime running light and **Position light**, replace the burnt-out incandescent bulb with a new incandescent bulb of the same model.

Turn signal, replace the burnt-out incandescent bulb with a new incandescent bulb of the same model.

- ⑨ **Dipped beam** and **Main beam**, position the new lamp in the housing, observing the correct positioning.

Daytime running light and **Position light**, fit the new bulb in the socket, observing the correct positioning, turn the bulb clockwise as far as the stop.

Turn signal, fit the new bulb in the socket, observing the correct positioning, turn the bulb clockwise as far as the stop.

- ⑩ **Dipped beam** and **Main beam**, press the locking spring and fit it into the holder to fix the lamp.

Daytime running light and **Position light**, fit the bulb socket into the headlight and turn clockwise as far as the stop.

Turn signal, fit the bulb holder into the headlight and turn clockwise until the stop.

- ⑪ **Dipped beam** and **main beam**, ensure the bulb is correctly secured in the set.

Daytime running light and **Position light**, make sure that the socket is correctly fixed in the assembly.

Turn signal, make sure that the socket is correctly fixed in the assembly.

- ⑫ **Dipped beam** and **Main beam**, place the rubber cover, paying attention to its perfect fit.

- ⑬ Installing the headlight → page 199.



- ⑭ **Dipped beam** and **main beam**, connect the lamp power supply connector, pressing it on till the stopper.

Daytime running light and **Position light**, fit the power connector into the lamp socket, pressing it as far as the stop.

Turn signal, insert the power connector into the lamp socket, pressing it as far as the stop.

- ⑮ Close the bonnet → page 215.

- ⑯ **Dipped beam** and **main beam**, after installing the new bulb, adjust the beam.

 The illustrations show the right-hand headlight from the rear. The left-hand headlight is a mirror image of the one shown. 

Changing bulbs in the rear bodywork lights

📖 Please refer to ⚠️ and ⌚ at the start of the chapter on page 198.

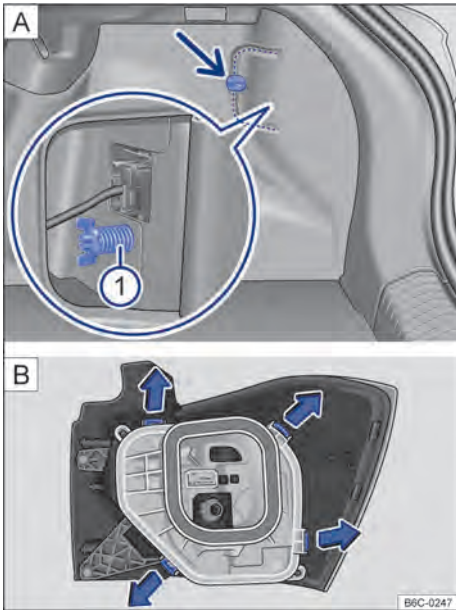

Fig. 168 (A) In the luggage compartment remove the cover and remove the wingbolt ① (magnifying glass) (B) Rear light: remove the bulb holder.

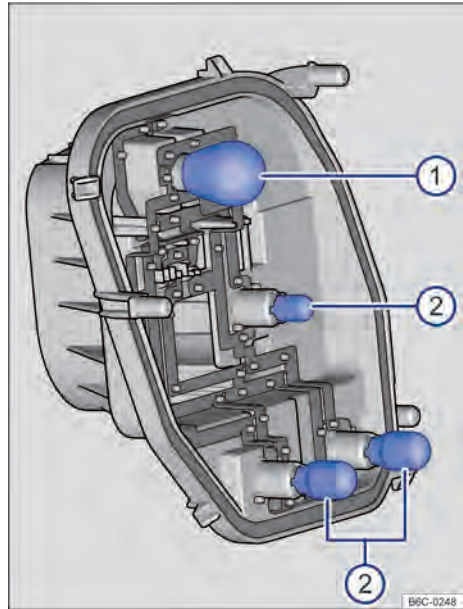

Fig. 169 Tail light: remove the bulbs

The actions should only be carried out in the specified order.

- ① Observe and follow the instructions on the checklist → page 198.
- ② Open the boot lid → page 69.
- ③ To open the light cover, rotate the retainer → Fig. 168 (A) (arrow).
- ④ Open the cover sideways together with the retainer.
- ⑤ Release the butterfly bolt ① (magnifying glass) and remove it while holding the tail light at the same time.
- ⑥ Carefully pull the tail light out to remove it from the bodywork → ⌚.
- ⑦ Disengage the power connector by pressing the latch and pull it in the direction of the arrow to completely remove the flashlight.
- ⑧ Place the rear light in a smooth and even surface.
- ⑨ To unlock the bulb holder, press each locking pawl → Fig. 169 (B) in the direction indicated by the arrows.
- ⑩ Carefully remove the bulb holder. ▶

- ⑪ To remove burnt-out light bulbs: → Fig. 169
 - ① press the bulb against the housing and turn counterclockwise. ② pull the bulb against the housing.
- ⑫ Replace the defective bulb with a new bulb of the same type.
- ⑬ Insert new bulbs into the respective bulb housing: → Fig. 169
 - Ⓐ press the bulb and turn clockwise until reaching the stop. Ⓑ press the bulb towards the housing as far as the stop.
- ⑭ Ensure that the bulbs are properly secured in the bulb holder.
- ⑮ Insert the rear light bulb support. The locking pawls → Fig. 169 must audibly engage.
- ⑯ Fit the bulb connector.
- ⑰ Carefully fit the rear light in the bodywork housing.
- ⑱ Hold the tail light in the installation position with one hand and install the butterfly bolt with the other hand → Fig. 168 ①.
- ⑲ Reposition the cover of the lamp in its position and rotate the lock to close.
- ⑳ Close the boot lid → page 69.

NOTICE

- Always take care when removing or fitting rear lights into the bodywork, in order to prevent damage to the paintwork or to other vehicle parts.
- Volkswagen recommends special attention to some plastic parts with clamps, which might break when removing or fitting bulbs.

Changing bulbs in the number plate light

📖 Please refer to ⚠ and ❶ at the start of the chapter on page 198.

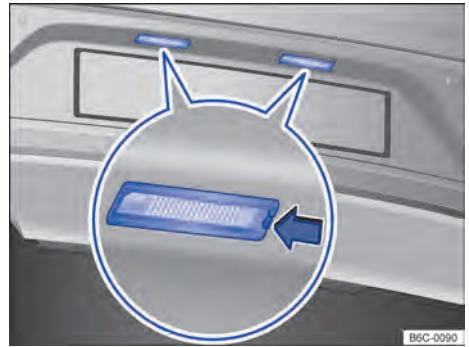

Fig. 170 On the rear bumper: number plate light.

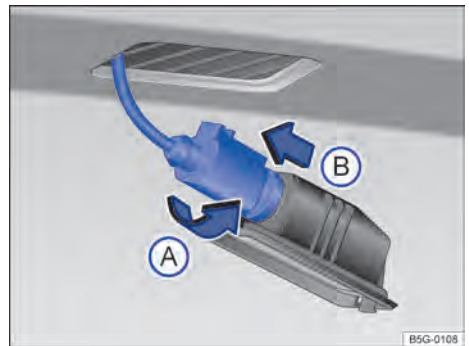

Fig. 171 Number plate light: remove the bulb socket.

A screwdriver may be used to remove the number plate light → ❶.

The actions should only be carried out in the specified order.

- ① Observe and follow the instructions on the checklist → page 198.
- ② Using a screwdriver, press the lock → Fig. 170 (arrow) to remove the assembly.
- ③ Rotate the socket **counter-clockwise** → Fig. 171 Ⓐ and remove the socket along with the bulb Ⓑ.
- ④ Pull the defective bulb from the socket to remove it.

- 5 Replace the defective bulb with a new bulb of the same type.
- 6 Carefully insert the new bulb into the socket.
- 7 Position the bulb support on the number plate light and press in the contrary direction of the one indicated by the arrow **A** up to the stopper.
- 8 Ensure that the socket is properly secured.
- 9 Position the number plate light set carefully into the opening in the bumper. Attention to the correct installation direction of the number plate light.
- 10 Press the number plate light in the bumper until it is audibly secured in place.
- 11 Ensure that the number plate light set is properly secured.

! NOTICE

Always take care when removing or fitting the number plate bulb in the rear bumper, in order to prevent damage to the paintwork or to other vehicle parts.

Troubleshooting

Please refer to and at the start of the chapter on page 198.

Depending on the vehicle version, the illumination indicator lamp may not be available.

Lighting

Central indicator lamp

OR plus additional text messaged ^{Driving} illumination partially or totally out of order.

Check the vehicle lights and replace the respective bulb when burned out → page 197. Case all bulbs are in order or if there is a damage seek your Volkswagen Dealership.

Fuses

Introduction

Several electrical consumers could share a single fuse. Conversely, a single consumer could have more than one fuse.

Therefore, fuses should only be replaced when the cause of a fault has been rectified. If a newly inserted fuse blows after a short time, the electrical system must be checked by a Volkswagen Dealership.

WARNING

Before initiating any work in the engine compartment, always read and observe the warning notes → page 213. The engine compartment of any motor vehicle is a dangerous area and may cause severe injuries.

WARNING

High voltages in the electrical system can cause electric shocks, severe burns and death!

- Never touch the electrical wiring of the ignition system.
- Avoid causing short-circuits in the electrical system.

WARNING

Using unsuitable or repaired fuses and bridging an electrical circuit without fuses can cause fires and severe injuries.

- Never fit fuses that have a higher fuse protection limit. Fuses must always be replaced with a new fuse which has the same amp rating (same colour and imprint) and size.
- Never repair a fuse.
- Never use a metal strip, paper clip or similar items to replace a fuse.

! NOTICE

- In order to avoid damage to the electrical system in the vehicle, the ignition, the lights and all electrical consumers must be switched off and the vehicle key removed from the ignition cylinder before changing a fuse.
- You can damage another position in the electrical system by using a fuse with a higher amp rating.

- Fuse boxes must be protected from dirt and moisture when opened. Dirt and moisture in the fuse boxes can damage the electrical system.

i A single consumer may have more than one fuse.

i Several consumers may share a single fuse.

Fuses in the dash panel

📖 Please refer to **⚠** and **🕒** at the start of the chapter on page 204.

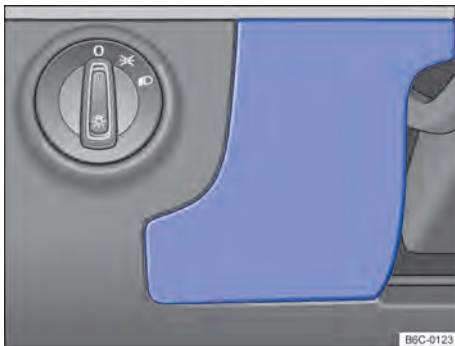

Fig. 172 On the driver's side of the dashboard: fuse box cover.

Fuses must always be replaced with a new fuse which has the same amp rating (same colour and imprint) and size.

Opening the fuse box in the dash panel

- Hold the fuse box cover → **Fig. 172** and pull forward.
- To *install*, put the cover on the fuse box of the dash panel and press until it audibly engages.

! NOTICE

- Remove the covers for the fuse boxes carefully and install them again properly so as to avoid damage to the vehicle.
- Fuse boxes must be protected from dirt and moisture when opened. Dirt and moisture in the fuse boxes can damage the electrical system.

Fuse box in the dashboard

📖 Please refer to **⚠** and **🕒** at the start of the chapter on page 204.

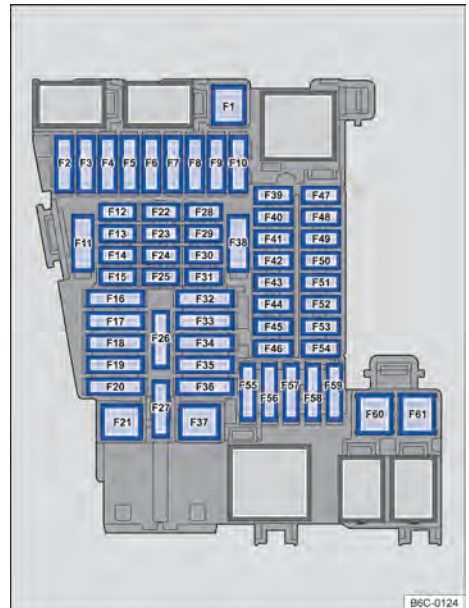

Fig. 173 On the dash panel: fuses arrangement.

Some fuses may be specific to certain versions.

Locations with respective functions for equipment that may be available in your vehicle are provided below:

- F1** Free
- F2** USB sockets
- F3** Free
- F4** Lights switch (BCM Entry)
- F5** Free
- F6** Central locking
- F7** Electric operation of the right front window (Polo Track)
- F8** Interior ventilation (Climatronic)
- F9** Electric left front window (Polo Track)
- F10** Free
- F11** Free
- F12** Free

- F13** Diagnostic socket/ rain and brightness sensor/ turn signals lever and window wiping lever (BCM Standard)/ light switch (BCM Standard)
- F14** Wiper lever / Wiper system / Window washing system
- F15** Instrument cluster
- F16** Vehicle exterior lighting - part 1 (BCM Standard)
or Turn signals and brake lights - part 1 (BCM Standard)
- F17** Electric window regulators - front right/ Electric window regulators - rear right/ Electric right hand side exterior mirror/ Exterior mirror tilt down
- F18** Windscreen wiper
- F19** Radio
- F20** Rear window heating
- F21** Ignition lock/ starter motor solenoid (ignition lock start)
- F22** Daytime running lights (BCM Entry)
- F23** Rear view camera system
- F24** USB Charging Socket / USB Mobile Data / Cordless Phone Charger
- F25** Multifunction steering wheel
- F26** Diagnostic interface for data bus
- F27** Main beam right side (BCM Entry) / main beam left side (BCM Entry)
- F28** Ultrasound sensor (alarm)
- F29** Free
- F30** Free
- F31** Climatronic control unit
or Air conditioner control unit
- F32** Ignition lock
- F33** Electric window regulators - front left/ Electric window regulators - rear left/ Electric left hand side electric exterior mirror
- F34** Headlight flasher (BCM Entry)
- F35** Vehicle exterior lighting - part 2 (BCM Standard)
or Turn signals and brake lights - part 2 (BCM Standard)
- F36** Horn
- F37** Free
- F38** Electronic control unit / Interior lighting (BCM Entry)
or Electronic control unit / Interior lighting (BCM Standard)
- F39** Parking sensor / Radar control unit
- F40** Light switch (BCM Standard) / Reverse gear light switch / Diagnostic socket / Interior mirror / Rear view camera / Headlight range control
- F41** Free
- F42** Clutch sensor/ Relay 1 of pull-away assist system/ Relay 2 of pull-away assist system/ Air conditioner pressure switch
- F43** Rear window wiper
- F44** Airbag system
- F45** Free
- F46** Free
- F47** License plate lighting
- F48** Keyless Access control unit / Right front position light (Polo Track)
- F49** Left dipped beam (BCM Entry)
- F50** Right dipped beam (BCM Entry)
- F51** Left front position light (Polo Track)
- F52** Left headlamp assembly with LED technology / Right side rear position light (Polo Track)
- F53** Automatic gearbox selector lever / Ignition key removal lock (only for vehicles with automatic gearbox and no Keyless Access)
- F54** Right headlamp assembly with LED technology Rear position light left side (Polo Track)
- F55** 12 V socket
- F56** Interior ventilation
- F57** Free
- F58** Windscreen and rear window washers
- F59** Free
- F60** Free
- F61** Free



Fuses in the engine compartment

📖 Please refer to ⚠ and ⌚ at the start of the chapter on page 204.

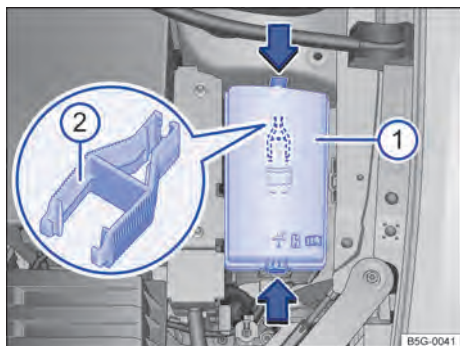

Fig. 174 In the engine compartment: fuse box cover ① with plastic claw ②.

Opening the fuse box in the engine compartment

- Open the bonnet ⚠ → page 215.
- Press the retainers in the direction of the arrow → Fig. 174 ① to release the fuse box cover.
- Remove the cover from the top.
- To *install*, place the cover on the fuse box and press down until the cover audibly locks on both sides.

On the inside of the engine compartment fuse box cover there may be a pair of plastic tweezers → Fig. 174 ② to extract the fuses.

! NOTICE

- Remove the covers for the fuse boxes carefully and install them again properly so as to avoid damage to the vehicle.
- Fuse boxes must be protected from dirt and moisture when opened. Dirt and moisture in the fuse boxes can damage the electrical system.

Fuse box in the engine compartment

📖 Please refer to ⚠ and ⌚ at the start of the chapter on page 204.

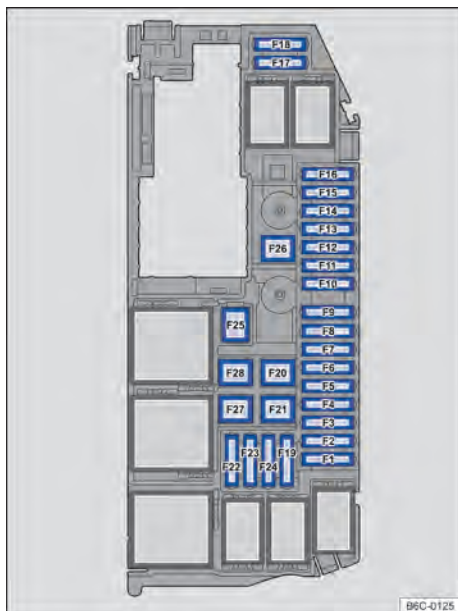

Fig. 175 In the engine compartment: fuse arrangement.

Some fuses may be specific to certain versions. Locations with respective functions for equipment that may be available in your vehicle are provided below:

- F1 Engine control unit
- F2 Fuel metering valve (TSI engine) / Water pump (TSI engine)
- F3 Lambda probe before catalytic converter / lambda probe after catalytic converter
- F4 Fuel pump
- F5 Radiator fan – electronics (TSI engine) / Oil pressure control valve (TSI engine) / Variable control shaft - intake / Variable control shaft - exhaust (TSI engine) / Activated charcoal filter valve / Ethanol sensor (TSI engine)
- F6 Heated start relay / Heated start control unit/ Ignition coils
- F7 Vacuum pump

- F8 Fuel pump relay/ Fuel injectors
- F9 Brake pedal sensor
- F10 Electronic control unit
- F11 Free
- F12 Air conditioning compressor
- F13 Free
- F14 Injection system main relay / Engine control unit/ ESC control unit
- F15 Automatic gearbox control unit
- F16 Free
- F17 Pull-away assist
- F18 Start assist(starter)
- F19 Free
- F20 ESC control unit
- F21 ESC control unit
- F22 Free
- F23 Free
- F24 Free
- F25 Radiator fan - 1nd speed
- F26 Radiator fan (TSI engine)
- F27 Radiator fan - 2nd speed
- F28 Free

Fuses in the engine compartment must only be replaced by a qualified workshop. Volkswagen recommends using a Volkswagen Dealership for this purpose.

Locations with respective functions and amp rating for equipment that may be available in your vehicle are provided below:

- ① 350 A, alternator.
- ② 80 A, free.
- ③ 150 A, engine compartment fuse box power supply.
- ④ 80 A, power supply 2 of the dash panel fuse box.
- ⑤ 125 A, power supply 1 of the dash panel fuse box.
- ⑥ 80 A, power steering.

Changing a blown fuse

📖 Please refer to ⚠️ and ⚠️ at the start of the chapter on page 204.

Fuse box in the engine compartment on the battery

📖 Please refer to ⚠️ and ⚠️ at the start of the chapter on page 204.

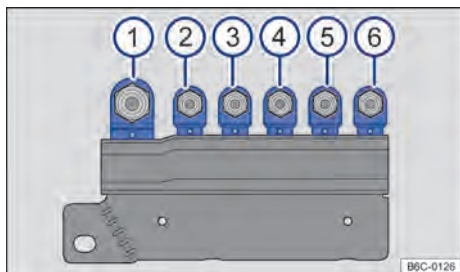

Fig. 176 In the engine compartment on top of the battery: fuse arrangement.

Fuses are located in the engine compartment, above the vehicle battery → ⚠️ in *Introduction* on page 204.

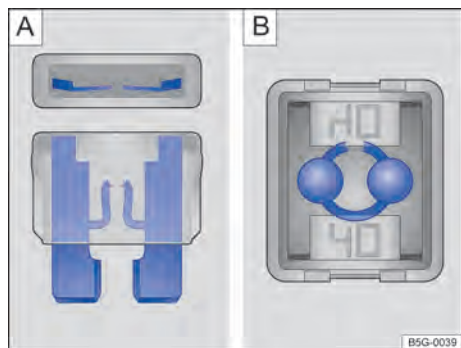

Fig. 177 Blown fuse: **A** flat fuse, **B** blocking fuse. ▶

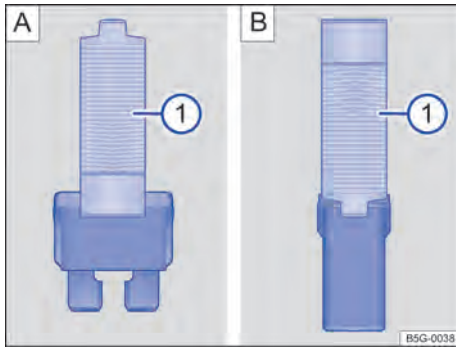

Fig. 178 Removing or installing the fuse with the plastic claw: [A]: flat fuse, [B] blocking fuse.

Fuse versions

- Flat standard blade fuse (ATO[®]).
- Small flat blade fuse (MINI[®]).
- Cartridge fuse (JCASE[®]).

Fuse colour coding

Fuses (ATO - MINI)

Colour Nominal current in amperes

- black** 1 A
- light brown** 5 A
- brown** 7.5 A
- red** 10 A
- blue** 15 A
- yellow** 20 A
- white or clear** 25 A
- green** 30 A
- orange** 40 A

Fuses (JCASE)

Colour Nominal current in amperes

- blue** 20 A
- white or clear** 25 A
- pink** 30 A
- green** 40 A
- red** 50 A
- yellow** 60 A

Preparations

- Switch off the ignition, the lights, and all electrical consumers.
- Open the respective fuse box → page 205.

Detecting a blown fuse

- Shine a flashlight onto the fuse. This will help you to spot the blown fuse more easily.
- A blown *blade fuse* (ATO[®], MINI[®]) is detected from above or from the side through its transparent body by the melted metal strip → Fig. 177 [A].
- A blown *cartridge fuse* (JCASE[®]) is detected from above by the melted metal strip visible through the transparent housing → Fig. 177 [B].

Changing a fuse

- If applicable, take the plastic tweezers → Fig. 178 ① out of the fuse box cover.
- According to the fuse type, apply the proper claw of the plastic tweezers → Fig. 178 [A] ① or → Fig. 178 [B] ① to the fuse sides.
- Pull out the blown fuse.
- If the fuse has blown, replace it with a new fuse of the *same* amp rating (same colour and same imprint) and *same* size → ①.
- After having replaced the fuse place the plastic claw pliers, if existing, back onto the cover.
- Install the fuse box cover.

⚠ NOTICE

You can damage another position in the electrical system by using a fuse with a higher amp rating. ◀

Jump starting

📖 Introduction

If the engine fails to start because of a discharged 12 V vehicle battery, it is possible to use another 12V battery from another vehicle to jump start the engine.

The discharged vehicle battery must be properly connected to the vehicle's electrical system.

The jump leads must have sufficient length to ensure proper distance between the vehicles.

⚠ WARNING

Using the jump leads incorrectly or completing the jump start procedure incorrectly can cause the battery to explode, which can lead to ▶

severe injuries. Please note the following points in order to reduce the risk of the battery exploding:



- All work on the vehicle battery and the electrical system can cause serious chemical burns, fire and electric shocks. Always read the warnings and safety information before carrying out any kind of work on the vehicle battery → page 226, *Vehicle battery*.
- The assistance providing vehicle's battery must be of the same voltage as the discharged vehicle battery (12-volt) and be approximately of the same capacity (see imprint on battery).
- Never charge a frozen or defrosted vehicle battery. A discharged vehicle battery can even freeze at temperatures of around 0° C (+32° F).
- The battery should be replaced if it has frozen or defrosted.
- A highly explosive mixture of gases is given off when jump starting the vehicle battery. Always keep fire, sparks, naked flames and lit cigarettes away from the vehicle battery. Never use a mobile telephone when the jump leads are being connected or disconnected.
- Only charge the battery in a well-ventilated space as the battery emits a highly explosive mixture of gases when the vehicle is being jump started.
- Position the jump leads so that they never come into contact with any moving parts in the engine compartment.
- Never confuse the negative and positive terminals or connect the jump leads incorrectly.
- Observe the jump lead manufacturer's instructions.

NOTICE

Please note the following in order to avoid considerable damage to the vehicle electrical system:

- short circuit can be caused if the jump leads are connected incorrectly.
- The vehicles must not touch each other, otherwise electricity could flow as soon as the positive terminals are connected.

Jump starting point (grounding point)

Please refer to  and  at the start of the chapter on page 209.

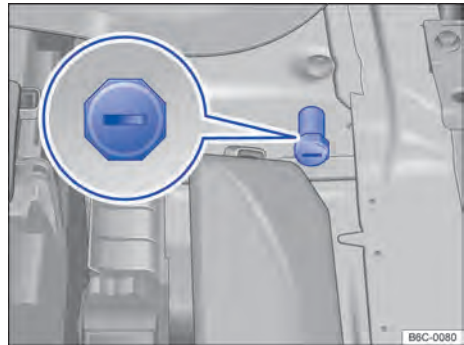

Fig. 179 On the engine compartment: jump starting point (grounding point).

The jump starting point is available for vehicle with Start-Stop System.

There is a jump starting point in the engine compartment – located on the interior wheel housing on the engine side, to connect the *black* → Fig. 179 jump lead.

The jump starting point is not designed to jump start other vehicles.

Only jump start the vehicle (grounding point) through this point.

How to start the engine using jump leads

📖 Please refer to ⚠️ and ⌚ at the start of the chapter on page 209.

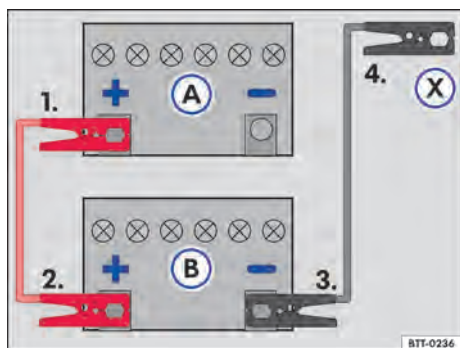

Fig. 180 Jump lead attachment diagram: discharged vehicle battery (A) and battery in the vehicle providing assistance (B).

Key for → Fig. 180:

- (A) Vehicle with discharged vehicle battery which is getting jump starting assistance.
- (B) Vehicle with the current supplying battery assisting jump starting.
- (X) Proper grounding point: jump starting point (grounding point) or a solid metal part firmly bolted to the cylinder block.

The discharged vehicle battery must be properly connected to the vehicle's electrical system.

The vehicles must not touch each other. Otherwise electricity could flow as soon as the positive terminals are connected.

Make sure the battery clamps have good metal-to-metal contact with the battery terminals.

If the engine does not start immediately, switch off the starter after about 10 seconds and try again after about one minute.

Attaching the jump leads

Connect the jumper cable strictly following the sequence 1 - 2 - 3 - 4 → Fig. 180.

- Switch off the ignition in both vehicles → page 104.
- Open the positive terminal cover.

- Connect one end of the *red* jump lead to the positive terminal (+) of the vehicle with the discharged battery → Fig. 180(A) → ⚠️.
- Connect the other end of the *red* jumper lead to the positive (+) terminal of the assisting battery (B).
- Connect one end of the *black* jumper lead to the negative terminal of the assistance supplying battery (B).
- Connect the other end of the *black* jump lead (X) to the vehicle with the discharged battery at the jump starting point (grounding point) or to a metal part firmly bolted to the cylinder block – but not near the battery (A) → ⚠️.
- Position the leads in such a way that they cannot come into contact with any moving parts in the engine compartment.

Starting the engine

- Start the engine of the vehicle which is providing assistance and let it run at idle.
- Start the engine of the car with the discharged vehicle battery and wait two to three minutes until the engine is “running smoothly”.

Removing the jump leads

- Before disconnecting the jump leads, switch off the dipped beam headlights if they are switched on.
- Turn the air conditioner and the rear window defroster heating of the vehicle with the flat battery on to reduce voltage peaks when disconnecting the jumper leads.
- Disconnect the jumper cable with the now started engine running exactly in the connection reverse sequence 4 - 3 - 2 - 1.
- Close the positive battery terminal cover.

⚠️ WARNING

Jump starting the vehicle incorrectly can cause the battery to explode, which can lead to serious injuries. Please note the following points in order to reduce the risk of the battery exploding:

- All work on the vehicle battery and the electrical system can cause serious chemical burns, fire and electric shocks. Always read the warnings and safety information before carrying out any kind of work on the vehicle battery → page 226, *Vehicle battery*.

Towing

Whenever it is necessary to tow your vehicle, use a specialized towing service, using tow trucks or platforms.

When using tow trucks, the vehicle must be securely fastened by the front wheels. Ensure that no gears are selected and the handbrake lever is not applied.

NOTICE

Always comply with applicable traffic laws regarding towing. 

- Make sure there is no one inside the vehicle when connecting battery jump leads. In case of electrical failure, airbags may be accidentally engaged and cause severe or even fatal injuries to vehicle occupants.
- Always wear suitable eye protection and never lean over the vehicle battery.
- Attach the connector cables in the correct order – the positive cable first, followed by the negative.
- Never connect the negative cable to parts of the fuel system or to the brake hose/pipe.
- Non-insulated parts of the battery clamps must not be allowed to touch. Additionally, the jump lead attached to the positive vehicle battery terminal must not touch metal parts of the vehicle.
- Check the window on the vehicle battery using a flashlight if necessary. If the display is light yellow or colourless, do not jump start the vehicle. Seek expert assistance.
- Avoid electrostatic discharge in the vicinity of the vehicle battery. The gas emitted from the vehicle battery could be ignited by sparks.
- Never use jump starting to start the engine if the vehicle battery is damaged, frozen or has defrosted.

NOTICE

Incorrectly attached jump leads could result in substantial damages to the vehicle's electrical system. 

Tow starting and towing

Introduction

For technical reasons, vehicles must not be tow started. Use jump leads to start the engine instead → page 209.

For technical reasons, vehicles with a discharged battery must not be tow started. Jump start the engine instead → page 209. 

Checking and refuelling

In the engine compartment

Safety guidelines for work in the engine compartment

Always park the vehicle on a levelled and stable surface before carrying out any work in the engine compartment.

The engine compartment of a motor vehicle is a hazardous area. Never carry out any work on the engine or in the engine compartment if you are not familiar with the necessary procedures and the general safety requirements, as well as without the unsuitable tools, fluids and resources available → ⚠. If necessary, such work must be carried out by a Volkswagen Dealership. Serious injuries can be caused if work is carried out incorrectly.

⚠ WARNING

Unintentional vehicle movements during service work can cause serious injury.

- Never work underneath a vehicle if it is not secured against rolling away. If you are working underneath the vehicle while the wheels are on the ground, the vehicle must be on a level, the wheels must be blocked and the vehicle key must be removed from the ignition cylinder.
- If you have to work underneath the vehicle, use suitable stands to provide extra support. The vehicle jack is not sufficient for this task and can fail, which can lead to serious injuries.
- The Start-Stop system must be manually disabled.

⚠ WARNING

The engine compartment of any motor vehicle is a dangerous area and may cause severe injuries!

- The utmost care and attention must be paid when carrying out any work and you must follow the general safety rules. Never take any risks.
- Never do any work on the engine or in the engine compartment unless you know exactly how to carry it out. If you are uncertain of

what to do, the work should be carried out by a Volkswagen Dealership. Serious injuries can result from work that has not been carried out properly.

- Never open the cover if you see steam or coolant escaping from the engine compartment. Hot steam or coolant can cause severe burns. Always wait until you can no longer notice steam or coolant coming from the engine compartment.
- Always let the engine cool down before opening the engine compartment cover.
- Hot parts of the engine or exhaust system may burn the skin.
- Before opening the engine compartment cover once it has cooled down:
 - Apply the handbrake and move the selector lever to position **P** or the manual gear lever to the neutral position.
 - Turn the ignition off and remove the vehicle key from the ignition lock.
 - Always keep children away from the engine compartment and never leave the vehicle unattended.
- The engine cooling system is under pressure when the engine is hot. Never open the cap of the coolant expansion tank when the engine is hot. Coolant may spray out and cause severe burns and injuries.
 - After cooling, turn the cap slowly and very carefully anticlockwise while exerting some downwards pressure on the cap.
 - Always protect the face, hands and arms from hot coolant or steam with a large, thick cloth.
- When refilling, do not spill any service fluids on engine components or on the exhaust system. Spilt service fluids may start fires.

⚠ WARNING

The high voltage in the electrical system can cause electric shocks, burns, serious injuries and death!

- Never short circuit the electric system. The vehicle battery could explode.
- Please note the following guidelines to help reduce the risk of an electric shock and serious injuries while the engine is running or being started:
 - Never touch the electrical wiring of the ignition system.

- Never touch electrical wiring.

WARNING

There are rotating components in the engine compartment that can cause serious injury.

- Never touch the radiator area or fan directly. Touching the rotary blades may result in severe injuries. The fan is temperature-controlled and can start automatically, even if the engine has been switched off and the vehicle key has been removed from the ignition cylinder.
- If any work has to be performed when the engine is started or with the engine running, there is an additional, potentially fatal, safety risk from the rotating parts, such as the Poly-V or drive belts, alternator, radiator fan, etc., and from the high-voltage ignition system. Always be extremely cautious.
 - Always ensure that no body parts, jewellery, ties, loose items of clothing or long hair can be caught up in rotating engine components. Before starting work, remove any jewellery and ties, tie up long hair and pull clothes in tightly to avoid them getting caught in the engine compartment.
 - Always depress the accelerator carefully and never thoughtlessly. The vehicle can move even while the handbrake is applied.
- Always make sure you have not left any objects, such as cleaning cloths and tools, in the engine compartment. Any forgotten items can cause malfunctions, engine damage and fires.

WARNING

Additional insulations such as covering the engine compartment, may damage the running of the engine, cause fire and severe injuries.

- Never cover the engine with covers or other isolations.

WARNING



Operating fluids and some materials in the engine compartment are highly flammable and may cause fires and severe injuries!

- Never smoke around the engine compartment.
- Never work near naked flames or sparks.

- Never spill fluids onto the engine. They could ignite on hot engine components and cause injuries.
- Please note the following when carrying out any work on the fuel system or the electrical system:
 - Always disconnect the vehicle battery. Ensure that the vehicle is unlocked before the battery is disconnected. Otherwise, the alarm system will be activated.
 - Never work in the direct proximity of heating systems, water heaters or any other open flames.

NOTICE

When refilling or changing operating fluids please ensure that the fluids are in the correct container. Incorrect operating fluids can cause serious functional problems and engine damages!

 Service fluids leaks are harmful to the environment. Regularly check the ground underneath your vehicle. If there are spots of oil or other fluids on the ground, the vehicle must be inspected by a Volkswagen Dealership. 

Preparing the vehicle for working in the engine compartment

Checklist

The following steps should always be carried out in the specified order before working in the engine compartment → :

- ✓ Park the vehicle on a levelled and stable surface.
- ✓ Depress and hold the brake pedal until the engine has stopped.
- ✓ Apply the handbrake → page 121.
- ✓ Position the gear shift lever in the neutral position → page 110 or move the selector lever to position **P** → page 111.
- ✓ Stop the engine and remove the key from the ignition lock.
- ✓ Allow the engine to cool down sufficiently.
- ✓ Children and other people should be kept well away from the engine compartment.
- ✓ Ensure that the vehicle cannot roll away unexpectedly. 

⚠ WARNING

Ignoring any of the points on this important safety checklist can lead to accidents and injuries.

- Always follow the instructions on the checklist and comply with applicable safety precautions.

Opening and closing the engine compartment cover

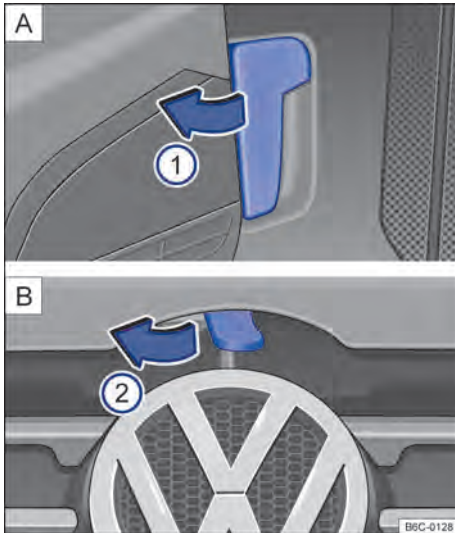

Fig. 181 [A] Bonnet release lever on the driver side footwell. [B] Bonnet release lever on the inner side of the bonnet.

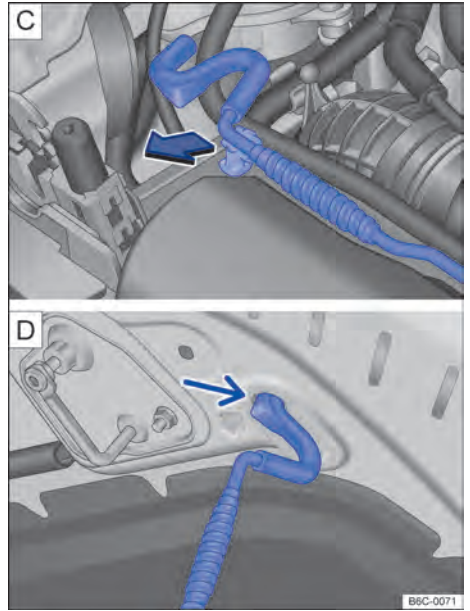

Fig. 182 [C] Bonnet stay. [D] Bonnet secured with the bonnet stay.

Opening the engine compartment cover

- Ensure that the windscreen wiper arms are positioned on the windscreen before opening the bonnet → ①.
- Open the driver door and pull the release lever in the direction indicated by the arrow → Fig. 181 [A] ①. The bonnet is released from its lock by a spring mechanism → ⚠.
- To fully open the bonnet raise it slightly and at the same time press the release lever on the inner side of the bonnet in the direction indicated by the arrow → Fig. 181 [B] ②.
- Take the bonnet stay out of the holder as indicated by the arrow → Fig. 182 [C] and insert it into the opening in the bonnet → Fig. 182 [D].

Closing the engine compartment cover

- Lift the bonnet slightly → ⚠.
- Take the bonnet stay out of the opening in the bonnet → Fig. 182 [D] and place it back into its resting position holder on the lock carrier → Fig. 182 [C].
- Release the bonnet at approximately 20 cm from the lock – *do not* press down!

If the bonnet is not closed, open it again and close it properly.

The engine compartment cover sits flush with the body parts around it when it is closed properly.

⚠ WARNING

When the open bonnet supported by the bonnet stay, do not push or apply additional force to close the bonnet, since this could cause bonnet damages and severe injuries.

⚠ WARNING

If the engine compartment cover is not closed properly, it can open suddenly while you are driving and completely obscure your view of the road. This could lead to accidents and severe injuries.

- After closing the engine compartment cover, always check that it is properly secured. The engine compartment cover must be flush with the surrounding body panels.
- If you notice that the bonnet is not closed properly while the vehicle is in motion, stop the vehicle as soon as possible and close the bonnet.
- Open or close the engine compartment cover only when you are sure that nobody is in its path.

📢 NOTICE

The bonnet should only be opened when the wiper arms are flush to the windows in order to avoid damage to the bonnet and window wiper arms.

Display indication

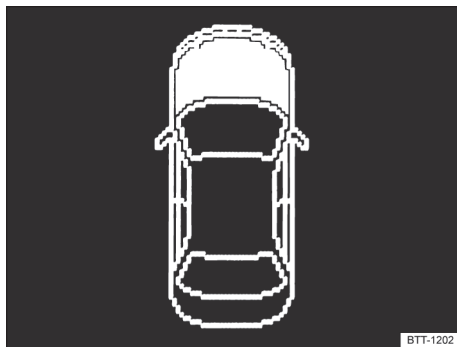

Fig. 183 On the instrument cluster display: incorrectly closed or open bonnet (schematic representation).

According to the version of the vehicle the representation of the bonnet on the display may not be available.

A symbolic representation → Fig. 183 on the instrument cluster display indicates that the bonnet is open or is not correctly closed.

🛑 Stop driving! if necessary lift and close the bonnet again.

The representation is also visible with the ignition turned off and is deleted a few minutes after the vehicle is locked with closed doors.

⚠ WARNING

Not heeding the warning indications may cause stoppages of the vehicle in the traffic, accidents and severe injuries.

- Never ignore lit warning lamps.
- Stop the vehicle as soon as possible and safe to do so.



According to the instrument cluster model, the display of the icons may vary.

Service fluids and consumables

All service fluids and consumables, e.g. toothed belts, tyres, coolant, engine oil, spark plugs and vehicle batteries, are being constantly perfected. For this reason, service fluids and consumables should be replaced at a Volkswagen

Dealership or qualified workshop. Volkswagen Dealerships are always updated about innovations.

⚠ WARNING

Unsuitable service fluids and consumables, and the incorrect use of these fluids and consumables, can cause accidents, serious injuries, burns or poisoning.

- Service fluids must be kept in their original sealed container.
- Never store service fluids in empty food containers, bottles or any other non-original containers as people finding these containers could drink them.
- Keep children away from all service fluids and consumables.
- Always read and follow the information and warnings on the service fluid packaging.
- When using products that give off harmful fumes, always work outdoors or in a well ventilated area.
- Never use fuel, turpentine, engine oil, nail varnish remover or other volatile fluids to wash, clean or care for your vehicle. These substances are poisonous and highly flammable. They could cause fires and explosions!

ⓘ NOTICE

- Only use suitable service fluids for refilling. Never use the service fluids not recommended. Failure to observe this warning can result in serious faults and engine damages!
- Optional equipment and other accessories in front of the air inlet reduce the cooling effect of the coolant. The engine may overheat at high ambient temperatures and high engine loads!



 Service fluids leaks are harmful to the environment. Regularly check the ground underneath your vehicle. If there are spots of oil or other fluids on the ground, the vehicle must be inspected by a Volkswagen Dealership.

Washer fluid



Fig. 184 On the engine compartment: window washer fluid reservoir cap.

The window washer fluid level should be checked regularly and topped up as necessary.

- Open the bonnet **⚠** → page 213.
- The washer fluid reservoir is identified by the  symbol on its cap → Fig. 184.
- Check whether there is enough window washer fluid in the reservoir.
- To top up, mix clean water with a washer fluid recommended by Volkswagen → . Observe the dilution instructions on the packaging.
- At low temperatures, add a special antifreeze agent so that the fluid cannot freeze → **⚠**.

Check the window washer water reservoir capacity in → page 273.

⚠ WARNING

Never mix antifreeze or other unsuitable additives into the window washer fluid. An oily film may otherwise be left on the screen, compromising visibility.

- Use clean water with a washer fluid recommended by Volkswagen.
- Suitable antifreeze agents may be added to the window washer fluid, if necessary.

ⓘ NOTICE

- Never mix other cleaning agents with the cleaning agents recommended by Volkswagen. This may cause the components to coagulate and, as a result, clog the window wiper nozzles.

- Never mix up service fluids when refilling! Failure to observe this warning can result in serious faults and engine damages!

Engine oil

Introduction

⚠ WARNING

Incorrect handling of engine oil can cause severe burns and injuries.

- Always wear eye protection when handling engine oil.
- Engine oil is toxic and must be stored out of the reach of children.
- Engine oil must be kept in the closed original container. This also applies to used oil before proper disposal.
- Never use empty food containers, bottles or other containers to store engine oil, since other people may then drink the engine oil.
- Regular contact with engine oil can damage the skin. Skin that has been in contact with engine oil should be washed thoroughly with water and soap.
- Engine oil becomes extremely hot when the engine is running and may scald skin severely. Always allow the engine to cool down.

 Leaking or spilt engine oil can pollute the environment. In order to prevent such event, replace the engine oil preferably at a Volkswagen Dealership, which is equipped with special tools and qualification to properly dispose of used engine oil.

- If engine oil or other fluid stains are found on the floor, underneath the vehicle, Volkswagen recommends inspecting the vehicle, preferably at a Volkswagen Dealership.

Engine oil specification

📖 Please refer to ⚠ at the start of the chapter on page 218.

VW 508 88 is the standard engine oil in your Volkswagen. This standard must be described on the oil packaging. Engine oils approved by Volkswagen are available at Volkswagen Dealerships.

When refuelling, engine oils approved by Volkswagen according to the **VW 508 88** standard can be mixed with each other.

If, in an emergency, no approved **VW 508 88** standard engine oil is available, you may temporarily use an engine oil that meets the following requirements: ACEA A3/B4 specification with the following viscosity grades: **SAE OW 30, SAE OW 40, SAE 5W 30, SAE 5W 40, SAE 10W 30** or **SAE 10W 40**. However, we recommend seeking a Volkswagen Dealership as soon as possible for the oil change with factory approved engine oil.



Engine oil specifications are available in the product package.

Engine oils are constantly being developed and improved. Volkswagen Dealerships are always updated about innovations. That is why Volkswagen recommends having engine oil changes performed at a Volkswagen Dealership.

ⓘ NOTICE

- Use only expressly Volkswagen approved engine oil specifications. Using other engine oils may cause damages to the engine!
- Do not mix additional lubricating additives to the engine oil. Damages caused by such additives are not covered by the warranty.
- Damages to the engine caused by using oil that does not meet the VW 508 88 standard are excluded from the warranty.

Changing the engine oil

 Please refer to  at the start of the chapter on page 218.

The engine oil must be changed regularly as described in → page 249. Ensure that such frequency is followed, especially when the vehicle is used in adverse conditions, which requires greater frequency of such services.

The engine oil and filter must be changed by qualified workshops due to the fact that such procedure requires special tools and expertise. This also ensures proper disposal of used oil. Volkswagen recommends using a Volkswagen Dealership for this purpose.

More information on service intervals can be found at → page 249.

WARNING

If, in exceptional cases, you have to carry out an oil change yourself, please note the following:

- Always wear eye protection.
- Always allow the engine to cool down completely to avoid burns.
- Keep your arms horizontal when removing the oil drain plug with your fingers to help prevent oil from running down your arm.
- Use a suitable container when draining the used oil. It must be at least large enough to hold the entire quantity of engine oil required for refilling.
- Never store engine oil in empty food containers, bottles or any other non-original containers as people finding these containers may not know that they contain engine oil.
- Engine oil is toxic and must be stored out of the reach of children.



NOTICE

Do not mix additional lubricating additives to the engine oil. Damages caused by such additives are not covered by the warranty.

 Volkswagen recommends replacing the oil and filter preferably at a Volkswagen Dealership, which is equipped with special tools and qualification to properly dispose of used engine oil.

- Never dispose of old oil in locations such as gardens, woods, sewerage systems, on streets and roads, or in rivers and waterways.
- In order to completely drain used oil, use an appropriate and sufficient recipient to collect all of the engine oil; refer to → page 273, *Capacities*.

Engine oil consumption

 Please refer to  at the start of the chapter on page 218.

Engine oil consumption may vary from engine to engine. Due to the design of internal combustion engines, in order to adequately lubricate components, part of the engine oil is consumed during normal engine operation. Therefore, engine oil consumption may vary throughout the engine's service life. In addition, depending on driving behaviors and vehicle use conditions, oil consumption may reach up to 0.5 l in 1,000 km. Engine oil level must therefore be checked at regular intervals – preferably when refuelling and before long journeys.

When the engine is working hard, the oil level must be kept within the → Fig. 185  area – for instance during long motorway cruising in summer or climbing mountain passes.

Checking the engine oil level and refilling engine oil

📖 Please refer to ⚠️ at the start of the chapter on page 218.

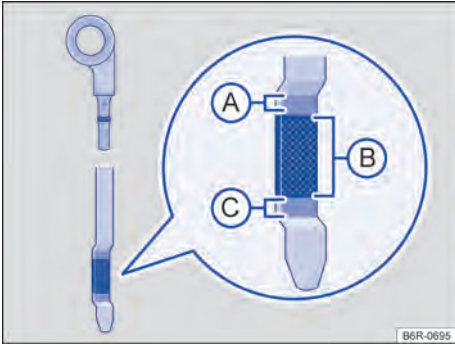

Fig. 185 Oil dipstick with markings.



Fig. 186 On the engine compartment: engine oil opening lid.

Key for → Fig. 185:

- (A) No filling up required.
- (B) Engine oil level in order.
- (C) Engine oil level too low - fill engine oil up.

Checklist

Carry out the steps in the specified order → ⚠️:

1. With the engine at **operating temperature**, park the vehicle on a level surface to ensure that the engine oil reading is correct.
2. Switch off the engine and wait a few minutes for the engine oil to flow back into the sump.
3. Open the bonnet ⚠️ → page 213.

4. Identify the engine oil filler cap and oil dipstick. The engine oil filler opening bears the  symbol on the cap → Fig. 186 and the oil dipstick has a coloured handle. If you cannot find the cap and dipstick please contact a Volkswagen Dealership or qualified workshop.
5. Pull the dipstick out of the guide tube and wipe it off with a clean cloth → ①.
6. Insert the oil dipstick into the guide tube again as far as it will go. If the oil dipstick has a marking, it must be adjusted to the corresponding groove on the upper edge of the guide tube upon insertion.
7. Pull the dipstick out again and read the engine oil level on the dipstick → Fig. 185 as follows:
 - ①: **do not** refill oil → ①. Proceed to step 16.
 - ②: proper oil level. Refill with oil (approximately 0.5 l). Proceed to step 8 or 16.
 - ③: recommended oil **must** be refilled until level reaches region ②. Proceed to step 8.
8. After reading the oil level, push the oil dipstick back into the guide tube as far as it will go.
9. Unscrew the engine oil filler opening cap → Fig. 186.
10. Only refill with engine oils approved by Volkswagen gradually, in small quantities (up to 0.5 l).
11. To avoid overfilling, wait for approximately one minute after each pour to allow the engine oil to flow into the oil sump up to the marking on the engine oil dipstick.
12. Read the engine oil level from the dipstick again before refilling with a further small quantity of engine oil. Never overfill engine oil → ①.
13. After the refilling procedure, the engine oil level must be at least in the centre of area → Fig. 185 ②, but never above area ① → ①.
14. If excess oil is accidentally refilled and the engine oil level is above the → Fig. 185 ① mark, **do not start the engine**. Go to a Volkswagen Dealership or qualified workshop.
15. After refilling, screw the engine oil filler cap back on correctly. ▶

Checklist (Continued)

16. Correctly insert the oil dipstick into the guide tube again as far as it will go.
17. Close the bonnet correctly  → page 213.

Check the engine oil level in → page 273.

WARNING

Engine oil can ignite if it comes into contact with hot engine components. This may cause fires, serious burns and injuries.



- If engine oil is spilt on cold engine parts it can heat up and ignite when the engine is running.
- Always ensure that the engine oil filler cap is securely tightened after refilling, and that the dipstick is properly inserted back into the guide tube. This will prevent the engine oil from draining out on to hot engine components when the engine is running.



NOTICE

- Do not start the engine when the engine oil level is above the range → Fig. 185 . Go to a Volkswagen Dealership or qualified workshop. The catalytic converter and the engine could otherwise be damaged!
- When refilling or changing operating fluids please ensure that the fluids are in the correct container. Incorrect operating fluids can cause serious functional problems and engine damages.



NOTICE

Use only cloths that don't shred to clean the oil dipstick, since such shredding could damage the engine.

 The engine oil level must never exceed the → Fig. 185  region, otherwise, the oil may be aspirated by the crankcase ventilation and discharged into the atmosphere by the exhaust system. Additionally, oil may be combusted inside the catalytic converter, damaging it.

 Leaking or spilt engine oil can pollute the environment. In order to prevent such event, Volkswagen recommends replacing the engine oil preferably at a Volkswagen Dealership, which is equipped with special tools and qualification to properly dispose of used engine oil. 



Troubleshooting

 Please refer to  at the start of the chapter on page 218.

Warning lamps and text messages may light up and be displayed on the instrument cluster display. In addition, acoustic signals may be sounded.

Engine oil

Central warning lamp 

and  **On:** engine oil pressure too low. 
Stop driving! Switch off the engine. Check the engine oil and refill if necessary → page 220. If the warning light remains lit and the oil level is suitable, *do not* drive on or keep the engine running. The engine could otherwise be damaged. Get immediate assistance from a Volkswagen dealership or specialized company.

and  **Fill up with engine oil.** Engine oil level too low. Switch off the engine. Check engine oil level → page 220.

Central warning lamp 

and  **Check oil level.** Engine oil level too low. Switch off the engine. Check engine oil level → page 220.



and  **On:** Engine oil level very low. Switch off the engine. Check engine oil level → page 220.

and  **Flashing:** engine oil system damaged. Get immediate assistance from a Volkswagen dealership or specialized company.

WARNING

Failure to observe the warning lamps and text messages could lead to your vehicle breaking down in traffic, and to accidents and serious injuries.

- Never ignore warning lamps or text messages.
- Stop the vehicle as soon as possible and when safe to do so. 

 The oil pressure warning lamp  is not indicative of the engine oil level. The engine oil level must be controlled in regular intervals, preferably whenever the tank is filled.

 Volkswagen recommends changing or refilling the engine coolant and its additives at a Volkswagen Dealership, which has proper fluid disposal procedures. Never dispose of used fluids in locations such as gardens, woods, sewerage systems, on streets and roads, or in rivers and waterways.

Engine coolant

Introduction

Never carry out any work on the engine coolant system if you are not familiar with the requisite procedures, or if you do not have access to the correct tools, operating equipment and fluids → ! In this case, all activities must be carried out by a qualified workshop. Volkswagen recommends using a Volkswagen Dealership for this purpose.

Serious injuries can be caused if work is carried out incorrectly.



WARNING

Engine coolant is toxic!

- Engine coolant must only be kept in sealed original containers in a safe place.
- Never store engine coolant in empty food containers, bottles or any other non-original containers as people finding these containers may then drink the engine coolant.
- The engine coolant must be stored out of the reach of children.
- Please note that the amount of correct coolant additive used must be sufficient for the lowest ambient temperature that you expect the vehicle to be exposed to.
- Coolant can freeze at extremely cold outside temperatures, causing the vehicle to break down. In this case, the internal vehicle heating will also no longer function, which may lower the body temperature of vehicle occupants with inadequate winter clothing.
- Prolonged exposure to cold and loss of body heat are hazardous factors to human health.

 Under no circumstance may old engine coolant be reused. Observe specific disposal regulations for this product.

Engine coolant specifications

 Please refer to  at the start of the chapter on page 222.

The engine cooling system is factory supplied with a mixture of **distilled water** and 40% G 12evo (TL-VW 774 L) engine coolant additive.

This mixture provides the necessary antifreeze of up to -25°C (-13°F) and protects the alloy parts of the cooling system against corrosion. The mixture also prevents scaling and raises the boiling point of the coolant.

In order to protect the coolant system, the proportion of coolant additive must *always* be at least 40%, even if antifreeze is not required in warm weather and warm climates.

If greater antifreeze is required in very cold climates, the proportion of antifreeze additive can be increased. However, the percentage of coolant additive must not exceed 60%, as this would reduce the antifreeze and the cooling effect.

When topping up the coolant, a mixture of **distilled water** and at least 40% coolant additive must be used for engines **G 12 plus-plus** or **G 12evo** (both lilac colour) in order to obtain the optimum corrosion protection → .

The **G 12evo** coolant acquired in the Brazilian market is ready for use, with proper distilled water and coolant ratios.

Mixing G 12evo with the engine coolants G 13 (TL-VW 774 J), G 12 plus-plus (TL-VW 774 G), G 12 plus (TL-VW 774 F) or G 12 (red colour) significantly compromises ant-corrosion properties and must be avoided.

G 12 plus (TL-VW 774 F) or G 12 (red) significantly compromises anti-corrosion protection and must be avoided

Refer to Volkswagen Dealerships for more information on coolants approved by Volkswagen. That is why Volkswagen recommends having engine oil changes done by a Volkswagen dealership.

⚠ WARNING

Insufficient antifreeze in the coolant system can cause the engine to break down.

- Ensure that the correct engine coolant additive ratio is used based on the ambient temperature to which the vehicle is exposed.

ⓘ NOTICE



Never mix genuine coolant additives with other coolants that have not been approved by Volkswagen. Mixing with non-approved coolants could cause serious damage to the engine and cooling system.

- Brown liquid in the coolant expansion tank indicates that the engine coolant has been contaminated. The coolant must be changed as soon as possible if this is the case. Failure to observe this warning can result in serious faults and engine damages!

 Under no circumstance may old engine coolant be reused. Observe specific disposal regulations for this product.

 Volkswagen recommends changing or refilling the engine coolant and its additives at a Volkswagen Dealership, which has proper fluid disposal procedures. Never dispose of used fluids in locations such as gardens, woods, sewerage systems, on streets and roads, or in rivers and waterways.

Checking coolant level and refilling coolant

 Please refer to  at the start of the chapter on page 222.

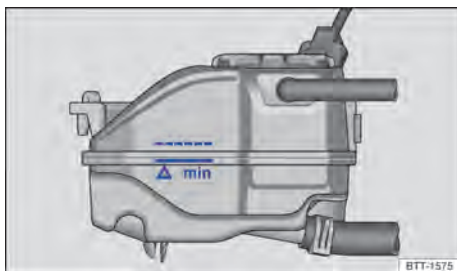





Fig. 187 On the engine compartment: marking on the coolant expansion tank.



Fig. 188 On the engine compartment: engine coolant expansion tank cover.

The warning lamp for the engine coolant will light up if the engine coolant level is too low.

◀ Preparations

- Park the vehicle in a flat and steady surface.
- Allow the engine to cool down → .
- Open the bonnet  → page 213.
- The coolant expansion tank has the  symbol on its cap → Fig. 188.

Checking the engine coolant level

- Check the coolant level at the side marking of the expansion tank when the engine is cold → Fig. 187.
- Refill the engine coolant if the liquid level is below the minimum marking ("min"). When the engine is warm, the coolant level may be slightly above the top end of the marked area. ▶

Refilling engine coolant

- Always protect your hands and arms from hot coolant or steam by placing a suitable cloth on the cap of the coolant expansion tank.
- Carefully unscrew the cap → ⚠ anticlockwise.
- Refill only **new** coolant according to Volkswagen specifications (→ page 222) → ⓘ.
- The coolant level must be between the marks on the expansion tank → Fig. 187. **Do not exceed the upper level marker when filling up** → ⓘ!
- Firmly screw-in the cap clockwise.
- If in an emergency you do not have access to the coolant of the required specification, do not use any other coolant additive! Instead, top off with **distilled** → ⓘ only. Then add the correct proportion of coolant additive → page 222 to re-established as soon as possible the correct mix.

⚠ WARNING

Hot steam or engine coolant can cause severe burns.

- Never open the bonnet if steam or engine coolant can be seen or heard coming out of the engine compartment. Always wait until no escaping steam or coolant can be seen or heard.
- Always let the engine cool down completely before carefully opening the bonnet. Hot parts may cause burns when touched.
- Before opening the engine compartment cover once it has cooled down:
 - Apply the handbrake and move the selector lever to position **P** or the manual gear lever to the neutral position.
 - Turn the ignition off and remove the vehicle key from the ignition lock.
 - Always keep children away from the engine compartment and never leave the vehicle unattended.
- The engine cooling system is under pressure when the engine is hot. Never open the cap of the coolant expansion tank when the engine is hot. Coolant may spray out and cause severe burns and injuries.
 - Turn the cap slowly and very carefully anticlockwise while exerting some downwards pressure on the cap.

- Always protect the face, hands and arms from hot coolant or steam with a large, thick cloth.
- When refilling, do not spill any service fluids on engine components or on the exhaust system. Spilt service fluids may start fires. In certain circumstances, the ethylene glycol in the engine can catch fire.

ⓘ NOTICE

- Do not exceed the upper level marker when filling up with engine coolant → Fig. 187. Otherwise the excess coolant will be pressed out of the cooling system when the engine is hot and could cause damage.
- If a large amount of coolant has been lost, do not refill the coolant until the engine has *completely cooled*. Substantial coolant loss is an indication of leaks in the engine cooling system. The engine cooling system must be checked by a Volkswagen Dealership or qualified workshop. Failure to do so can result in engine damage!
- When refilling operating fluids, please ensure that the correct container is filled. The use of incorrect operating fluids could result in serious malfunctions and engine damage!

Brake fluid



Fig. 189 On the engine compartment: brake fluid reservoir cap.

Brake fluid will gradually absorb water from the surrounding air. The brake system will be damaged if there is too much water in the brake fluid. The boiling point of the brake fluid is also considerably reduced by the water content. Heavy use ▶

of the brakes may cause a vapour lock in the brake system if the water content is too high. Vapour locks reduce levels of braking power, considerably increase braking distance and can even cause the brake system to fail completely. Your own safety and that of other road users depends on having a brake system that functions properly at all times → .



Brake fluid specification

Volkswagen has developed a brake fluid optimised for the brake system in the vehicle. To ensure optimal operation of the brake system, Volkswagen recommends the use of **DOT 4** standard brake fluid → Fig. 189. Additionally, we recommend using original Volkswagen brake fluid.

Before using a particular brake fluid, check that the specifications printed on the container correspond to the vehicle requirements.

Suitable brake fluids may be acquired at a Volkswagen Dealership.

Brake fluid level

 Brake fluid level is too low.  **Stop driving!** Check brake fluid level.

The brake fluid level must always be between the MIN and MAX marking on the brake fluid container or above the MIN marking → .

The brake fluid level cannot be checked accurately in all models, since engine components conceal the brake fluid container. When the brake fluid level cannot be accurately read, please seek a Volkswagen dealership or expert technical assistance.

The brake fluid level drops slightly when the vehicle is being used as the brake pads wear and the brakes are automatically adjusted.

Changing brake fluid

The brake fluid must be changed by a qualified workshop. Volkswagen recommends using a Volkswagen Dealership for this purpose. Only brake fluid that conforms with the required specification should be refilled.

WARNING

Brake failure or reduced braking effect can be caused by the brake fluid level being too low or by brake fluid that is too old or unsuitable.

- The brake system and brake fluid level must be checked regularly.
- Renew the brake fluid regularly.
- Heavy use of the brakes may cause a vapour lock if the brake fluid is left in the system for too long. Vapour locks reduce levels of braking power, considerably increase braking distance and can even cause the brake system to fail completely.
- Please ensure that the correct brake fluid is used. Only use brake fluid compliant with the DOT 4 standard. Any other brake fluid or a low-quality one can affect the functioning of the brakes and reduce their effectiveness. Do not use the brake fluid if the DOT 4 standard is not indicated in the fluid package.
- The refilled brake fluid must be new.

WARNING

Brake fluid is toxic.



- In order to reduce the risk of poisoning, never use bottles or other containers to store brake fluid. These containers could encourage other people to drink out of them, even if they are labelled otherwise.
- Brake fluid must always be stored in its original sealed container and kept out of the reach of children.

NOTICE

Spilt or leaked brake fluid may damage the vehicle paintwork, plastic parts, and tyres. Immediately clean spilt or leaked brake fluid over the vehicle's paintwork or other vehicle parts.

- Never mix different types of brake fluids.
- Clean the cover before removing it and placing it back in the reservoir.

 Brake fluid can pollute the environment. Collect and dispose of used fluids properly.

 Replacing brake fluids requires special procedures, equipment and knowledge, in addition to specific environmental standards. Therefore, disposing the brake fluid and its respective package as common trash is prohibited. Applicable laws establish specific disposal procedures for these cases. For your safety and convenience, Volkswagen recommends replacing the brake fluid at Volkswagen Dealerships. 

Warm starting system (E-FLEX)

Information on the warm starting system

According to the vehicle version, the warm start system may not be available.

The warm starting system will switch on automatically whenever the coolant temperature is too low and the fuel tank has a high percentage of ethanol.

The indicator lamp  will be lit in the instrument cluster upon switching on the ignition. Wait until the indicator lamp on the instrument cluster is switched off before starting the engine.

If the engine starting attempt occurs before the indicator lamp  is switched off on the instrument cluster, the lamp will flash, indicating the need to interrupt the starting process → page 105.

In case of warm starting system temperatures below 0° C, under severe engine operating conditions (e.g. weak vehicle battery, low fuel quality, unperformed engine service, exhaust system emissions indicator lamp (OBD) lit → page 192, etc), more than one starting attempt may be required.



In order to prevent starting issues with cold engine, after refilling the vehicle's fuel (replacing the current fuel in the vehicle), the vehicle must run approximately 5 kilometres in order to recognize the new fuel or mixture → page 189.

In case of failure in any warm starting system component, the indicator lamp  will light up and remain lit after the engine is started. In this case, there may be difficulties in starting the cold engine, and we recommend submitting the system to due inspection by a Volkswagen Dealership or qualified workshop.

NOTICE

- If the TOTALFLEX vehicle is immobilized by “**lack of fuel**”, the vehicle must be refilled with the last type of fuel used - petrol or ethanol.
- If it is necessary to fill the tank with a different type of fuel, the following may occur:
 - Cold starting difficulties.

- Considerable decrease in engine performance.
- The vehicle must run for approximately 5 kilometres to recognize the new fuel type, in order to prevent any of the scenarios above.

 When filling, fuel may be spilt on the ground, polluting the environment. Always fill the at authorized filling stations with proper fluid collection and disposal systems. 

Vehicle battery

Introduction







The vehicle battery is a component of the electrical system in the vehicle.

Never carry out any work on the electrical system if you are not familiar with the necessary procedures and the general safety requirements and only unsuitable tools are available → ! In this case, all activities must be carried out by a qualified workshop. Volkswagen recommends using a Volkswagen Dealership for this purpose. Serious injuries can be caused if work is carried out incorrectly.

Vehicle battery installation location

The vehicle battery is located in the engine compartment.

Meaning of warnings on the vehicle battery

-  Always wear eye protection!
-  Electrolyte is very corrosive and caustic. Always wear protective gloves and eye protection!
-  Fires, sparks, smoke, and naked lights are prohibited!
-  A highly explosive mixture of gases is given off when the vehicle battery is charging!
-  Always keep children away from acid and the vehicle battery! 

⚠ WARNING

Works on the vehicle battery and the electrical system can cause severe chemical burns, fire and electric shocks. Always read the following warnings and safety information before carrying out any kind of work:

- Switch off the ignition and all electrical consumers before carrying out any work on the vehicle battery and also disconnect the negative cable from the vehicle battery.
- Children should always be kept away from electrolyte and the vehicle battery.
- Always wear eye protection.
- Electrolyte is very aggressive. It can burn the skin and can cause blindness. When working with the battery, ensure that your hands, arms and face in particular are protected from acid spillages.
- Never open a vehicle battery.
- Do not smoke and never work near naked flames or sparks.
- When handling cables and electrical equipment, avoid generating sparks and electrostatic charge.
- Never short circuit the battery poles.
- Never use a damaged vehicle battery. It can explode. A damaged vehicle battery must be replaced as soon as possible.
- A damaged or frozen vehicle battery must be replaced immediately. A discharged vehicle battery can even freeze at temperatures of around 0° C (+32° F).
- Ensure there is no one inside the vehicle while replacing the battery. In case of electrical failure, airbags may be accidentally engaged and cause severe or even fatal injuries to vehicle occupants.

ⓘ NOTICE

- Never disconnect the vehicle battery with the ignition switched on or the engine running, and never connect it to another battery; otherwise the electrical system and electronic components may be damaged.
- Do not allow direct sunlight onto the vehicle battery for extended periods, since the UV rays could damage the battery housing.

- If the vehicle is parked for extended periods, ensure the vehicle is not parked in open spaces in order to protect the vehicle battery from "freezing" and being damaged.

🌿 Never install damaged or improperly sealed batteries. Dispose of batteries according to environment protection standards → page 228, *Charging, replacing, disconnecting and connecting the vehicle battery*.

📖 After starting the engine with a fully discharged or replaced battery, system settings (such as time, date, convenience settings and programs) may have been deprogrammed or deleted. Check and adjust settings after the vehicle battery is sufficiently charged. ▶

Checking the electrolyte level of the vehicle battery

📖 Please refer to ⚠ and ⓘ at the start of the chapter on page 227.



Fig. 190 On the engine compartment: example of display position on the upper side of the vehicle battery.

The electrolyte level of high-mileage batteries, in hot countries and of older vehicle batteries should be checked regularly. The vehicle battery is otherwise maintenance-free.

Preparations

- Preparation for working in the engine compartment → page 213
- Open the bonnet ⚠ → page 215. ▶

Checking the electrolyte level

To access the round visor it is necessary to remove the fuse box support from the battery. Volkswagen recommends having the battery checked at a Volkswagen Dealership or qualified workshop.

- Ensure that sufficient light is available in order to see the colours clearly. Never use naked flames or glowing items as a light source.
- The round display → Fig. 190 on the top side of the vehicle battery changes its colour according to the electrolyte level.
- Tap lightly on the display to eliminate air bubbles that may affect the colour.

Light yellow or without colour The electrolyte level of the battery is too low. The vehicle battery should be checked and replaced by a Volkswagen Dealership or qualified workshop.

Black The electrolyte level of the battery is in order.



Eventual different colours are destined to battery diagnosis at a Volkswagen Dealership or qualified workshop.

WARNING

Handling the vehicle battery may cause chemical burns, explosions or severe electrical shocks.

- Always wear protective gloves and eye protection.
- Electrolyte is very aggressive. It can burn the skin and can cause blindness. When working with the battery, ensure that your hands, arms and face in particular are protected from acid spillages.
- Never tip the vehicle battery. Electrolyte might leak from the vents and cause chemical burns.
- Never open a vehicle battery.
- In case of spilled electrolyte on the skin or eyes, wash the affected area immediately with cold water for a few minutes. Then seek medical assistance.
- In case of electrolyte ingestion, seek medical assistance immediately.

Charging, replacing, disconnecting and connecting the vehicle battery

 Please refer to  and  at the start of the chapter on page 227.

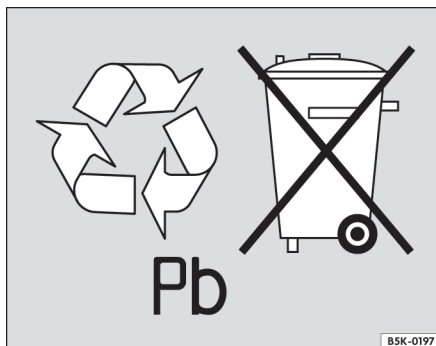



Fig. 191 Batteries contain toxic substances and must be recycled. Therefore, batteries may not be disposed in common trash; they must be returned to the reseller after replacement.

Charging the battery

The vehicle battery should be charged by a qualified workshop, as the technology used in factory-fitted batteries requires voltage-limited charging → . Volkswagen recommends using a Volkswagen Dealership for this purpose.

Replacing the battery

The battery has been developed to suit the conditions of its location and has special safety features. If a vehicle battery has to be replaced, discuss the electric compatibility, appropriate load capacity (A/h) for the vehicle, size and necessary servicing, output and safety requirements for the new vehicle battery with a Volkswagen Dealership before purchasing. Volkswagen recommends changing the vehicle battery in a Volkswagen Dealership.

Disconnecting the battery

Please note the following points if the vehicle battery has to be disconnected from the electrical system in the vehicle: 

- Switch off the ignition and all electrical consumers.
- The vehicle must be unlocked before disconnecting the battery as the alarm will otherwise be triggered.
- First disconnect the negative cable and then the positive cable → .

If the vehicle is stationary for a long period of time, disconnect the negative battery cable. Otherwise, the battery could be discharged by the current consumers in the vehicle, preventing the engine from starting.

Connecting the battery

- Switch off all electrical consumers and the ignition before reconnecting the vehicle battery.
- First connect the positive cable and then the negative cable → .

In case of issues during start-up in low gears, switch the ignition on for 30 seconds and then switch it off. Then, switch the engine on.

Various indicator lamps may light up after the vehicle battery has been connected and the ignition is switched on. Such lamps go out after a few seconds. If the indicator lamps remain lit up, the vehicle should be checked by a Volkswagen Dealership.

If the vehicle battery was disconnected for long periods, the system may not be able to calculate or correctly display the time when the next service is due → page 14. Observe the maximum permissible service intervals in the → page 249.

Vehicles with Keyless Access: if, after connecting the battery the ignition cannot be turned on, unlock and lock the vehicle from outside. Then try to turn the ignition on again. Case the ignition can still not be turned on, contact a Volkswagen dealership.

Automatic consumer deactivation

Through a smart electric management system, in case of high battery demand, different measures are adopted to prevent the battery from being discharged:

- Slow-gear rotation is increased in order for the alternator to provide more current.
- If necessary, some power consumers are limited or deactivated completely, in case of emergency.
- During engine start-up, the 12 V and lighter voltage supply may be temporarily interrupted.

The electric management system does not always prevent the battery from being discharged. This may occur if the ignition remains switched on while the engine is turned off for extended periods, or if the indicator light remains on for extended periods, while the vehicle is parked.

What can cause the vehicle battery to discharge?

- Long periods at a standstill in which the engine is not running, especially if the ignition is switched on.
- Use of electrical consumers when the engine is switched off.

WARNING

Incorrect attachment of the battery and the use of incorrect vehicle batteries can cause short circuits, fire and serious injuries.

- Always use maintenance-free and leak proof batteries which have the same properties, specifications and dimensions as the factory-fitted vehicle battery.
- Ensure there is no one inside the vehicle while replacing the battery. In case of electrical failure, airbags may be accidentally engaged and cause severe or even fatal injuries to vehicle occupants.

WARNING

A highly explosive mixture of gases is given off when the vehicle battery is charging!

- Vehicle batteries should only be charged in well-ventilated spaces.
- Never charge a frozen or defrosted vehicle battery. A discharged vehicle battery can even freeze at temperatures of around 0° C (+32° F).
- A vehicle battery must be replaced if it has been frozen.
- Incorrectly connected cables can cause a short circuit. First connect the positive cable and then the negative cable.

NOTICE

- Only recode the radio if the battery is reconnected and the radio is switched on before the ignition. Please refer to a qualified Volkswagen Dealership to recode the radio system.
- Never disconnect or connect the vehicle battery with the ignition switched on or the engine running, and never connect it to another battery; otherwise the electrical system and electronic components may be damaged.
- Never connect equipment which generates electricity, such as solar panels or battery charging units for charging the vehicle battery, to the 12-volt socket or to the cigarette lighter. This can damage the vehicle electrical system.

 Batteries may contain toxic substances such as sulphuric acid and lead. This product cannot be disposed / discarded along with common trash. There are specific legal requirements regarding the disposal / discarding of used batteries. For your safety and convenience, Volkswagen recommends replacing vehicle batteries at a Volkswagen Dealership or qualified workshop.

 The acid solution and lead contained in the battery could contaminate the ground and waters if disposed of incorrectly. Consumption of lead-contaminated waters may cause high blood pressure, several gastrointestinal disorders and anaemia (weakness and drowsiness).

Troubleshooting

 Please refer to  and  at the start of the chapter on page 227.

Vehicle battery

Central warning lamp

and  Fault in the alternator. The vehicle battery is not be charged by the alternator.

The vehicle battery will not be charged by the alternator while the vehicle is in motion.

- Switch off unnecessary electrical consumers.
- Go to a Volkswagen Dealership or qualified workshop.
- Have the electric system checked.

For vehicles with Start-Stop system, the Start-Stop system cannot start the engine → page 108.

Central warning lamp

and  Low battery.

The vehicle battery is charged by the alternator while driving however the charge level is not sufficient

- Charge the battery by driving around for a longer period of time.

For vehicles with Start-Stop system, the Start-Stop system cannot start the engine → page 108.

 Replace the battery.

The vehicle battery is not in good condition.

- Go to a Volkswagen Dealership or qualified workshop.

For vehicles with Start-Stop system, the Start-Stop system cannot start the engine → page 108.

When switching the ignition on, certain warning and indicator lamps flash to check functions. Such lamps go out after a few seconds.

WARNING

Failure to observe the warning lamps and text messages could lead to your vehicle breaking down in traffic, and to accidents and serious injuries.

- Never ignore any warning lamps or text messages that appear.
- Stop the vehicle as soon as possible and when safe to do so.

NOTICE

Failure to observe the illuminated indicator lamps could lead to vehicle damages.

Wheels and tyres

Tyre monitoring system

Introduction

The tyre monitoring system warns the driver when tyre pressure is too low.

Depending on the vehicle version, the tyre monitoring system may not be available.

⚠ WARNING

The intelligent technology shipped with the tyre monitoring systems cannot go beyond the limits imposed by physics and will only operate within the limitations of the system. Inadequate use of the wheels and tyres may cause a sudden loss of tyre pressure, displacement of the treads of the tyres and even their blowing up.

- Check tyre pressures regularly and always keep to the specified tyre pressure value → page 236. When the tyre pressure is very low, the tyre can become so hot that the tyre tread may come loose and the tyre blow up.
- Check and correct the tyre pressures always according to the prescribed values on the sticker → page 236.
- Check the tyre pressures regularly on cold tyres. If necessary, calibrate the tyres mounted on the vehicle when they are cold according to the indicated values on the sticker → page 236.
- Check the tyres regularly, looking for wear and tear signs.
- Never exceed the top speed and load capacity permitted for the fitted tyres.



A too low tyre pressure increases fuel consumption and tyre wear.



When driving for the first time with new tyres at high speed, they may expand somewhat and so a single tyre pressure warning may be issued.



Old tyres should only be replaced by tyres that have been approved by Volkswagen for the vehicle type.



Do not rely only on the tyre monitoring system. Regularly check the tyres to ensure that their pressures are correct and to see whether there are signs of damage, such as holes, cuts, cracks or bubbles. Remove foreign bodies from the tread of the tyre before they penetrate the tyre interior.

Tyre Pressure Loss Indicator



Please refer to  at the start of the chapter on page 231.

Operation instructions

The tyre pressure loss indicator compares, assisted by the ABS sensors, the speed and, consequently the rolling circumference of each tyre, among other things.

The rolling circumference of the tyre can change:



- When the tyre pressure has been changed.
- When the tyre pressure is very low.
- When the tyre has structural damages.
- When the vehicle is loaded on only one side.
- Whether an emergency wheel is mounted.
- Whether one wheel per axle has been changed.

The tyre pressure loss indicator (⚠) can be delayed or display nothing under given conditions such as, for example, when the driving style is very sporty, on snow covered roads or on unpaved roads,

Setting the tyre pressure loss indicator

After a tyre pressure change or after changing one or more wheels, the tyre pressure loss indicator must be reset again. This is also valid after exchanging the wheels, for example the front wheels with the rear wheels.

To reset the system the saved values must first be reset.

- Switch on the ignition.
- According to the version of the vehicle and of the radio, press the  button on the radio system → page 28.
- Open the menu **Vehicle settings** on the radio system.
- Touch the  function button.

- Touch the **SET** function button.
- If the 4 tyre pressures correspond to the prescribed values, touch the **Confirm** function button to save the tyre pressures.

OR



- Switch on the ignition.
- *Depending on the vehicle and radio versions, on the radio display touch the settings button .*
- Touch the **Car** function button.
- Touch the **Tyres** function button.
- Touch the **Configure** function button.
- If the 4 tyre pressures correspond to the prescribed values, touch the **Confirm** function button to save the tyre pressures.

After a longer driving period and at different speeds, the system resets the new values automatically and monitors them.



The tyre pressure loss indicator must be reprogrammed again under the following circumstances:

- When the tyre pressures have been adjusted.
- When one or more wheels have been exchanged.
- When the wheel positions have been changed, for example, the front wheels to the rear → page 234.

 The tyre pressure loss indicator does not work when the ESC or the ABS are damaged → page 127.

 After a low tyre pressure warning turn the ignition off and on again. Only then can the tyre pressure loss indicator be programmed again. 

Tyre pressure loss indicator troubleshooting

 Please refer to  at the start of the chapter on page 231.

 on

The pressure of one or more tyres went down or the tyre suffered a structural damage.

-  **Stop driving!**
- Check all the tyre pressures and adjust → page 236.
- Replace the damaged tyres.
- Resetting the tyre pressure loss indicator again → page 231.
- Seek assistance from a Volkswagen Dealership if necessary.



 flashes for about one minute and then remains permanently lit

System damaged.

-  **Stop driving!**
- Turn the ignition off and on again.
- Resetting the tyre pressure loss indicator again → page 231.
- Seek assistance from a Volkswagen Dealership if necessary.

WARNING

Different tyre pressures or very low tyre pressures may result in collapsing tyres, loss of control over the vehicle, accidents, severe injuries and loss of life.

- If the indicator lamp  lights up, stop immediately and check all tyres → page 236.
- Different tyre pressures or very low tyre pressures may increase tyre wear, deteriorate stability and increase braking distance.
- Different tyre pressures or very low tyre pressures may result in a sudden collapse of the tyre, causing the tyre to blow up and the loss of control over the vehicle.
- The driver is responsible for the correct pressure in all the tyres of the vehicle. The recommended tyre pressure is always available on a sticker → page 236.
- The tyre monitoring system can only fulfil its mission when all tyres have the correct pressure when cold. 

- Using incorrect tyre pressure values may cause accidents and damages to the tyres. All tyres must always have their tyre pressure adjusted to the carried load condition → page 236.
- Prior each trip, always calibrate the tyres to the correct tyre pressure → page 236.
- When travelling with very low tyre pressure, the tyres necessarily undergo more deformations. This way the tyres may get so hot that the tread may come loose, the tyres may blow up and loss of control over the vehicle may occur.
- High speeds and overload may heat a tyre in such a way that the tyre may blow-up and lead to loss of control over the vehicle.
- If the tyre pressure is too low or too high, the tyres will wear prematurely and the vehicle will not handle well.
- If the tyre is not “punctured” and is not necessary to change the wheel immediately, drive at low speed to the nearest Volkswagen dealership, to check and correct the tyre pressures → page 236.

WARNING

Failure to take notice and heed activated warning lamps and text messages could cause the vehicle to stop in middle of traffic, severe accidents and injuries.

- Never ignore the warning lamps and the text messages.
- Stop the vehicle as soon as possible and when safe to do so.

NOTICE

Failure to observe the illuminated indicator lamps could lead to vehicle damages.

 With the ignition turned on, if a low tyre pressure is detected, the indicator lamp lights up (L). In addition, an acoustic warning sounds and a text message may be exhibited.

 When a damage to the system is detected with the ignition turned on, the yellow (L) indicator lamp flashes for a while and then stays permanently lit. In addition a text message may be exhibited.

 A long drive over unpaved roads or a sportive driving style may temporarily disable the tyre pressure loss indicator. The indicator

lamp displays the malfunction, but goes off, however, when the road conditions or driving style change.

Important information on wheels and tyres

Introduction

Tyres are the most used and most underestimated parts of a vehicle. Tyres are very important as the narrow tyre surfaces are the only contact between the vehicle and the road.

The service life of tyres is dependent on tyre pressure, driving style, handling, and fitting.

Volkswagen recommends that work on tyres and wheels is carried out by a qualified workshop. They are familiar with the procedure and have the necessary special tools and spare parts as well as the facilities for proper disposal of old tyres. Volkswagen recommends using a Volkswagen Dealership for this purpose.

WARNING

Worn or damaged tyres cannot provide full levels of vehicle control and braking power.

- Incorrect handling of wheels and tyres can reduce vehicle safety and cause accidents and severe injuries.
- All 4 wheels must be fitted with radial tyres of the same type, size (rolling circumference) and the same tread pattern.
- New tyres will have to be run in, as they will initially have reduced grip and braking effect. Drive particularly carefully for the first 600 km in order to prevent accidents and severe injuries.
- At high and continuous speed, tyres with low pressure are excessively heated, which could cause the treads from detaching or even exploding. Always maintain the recommended tyre pressure.
- Never drive with worn tyres or tyres that are damaged (cuts, cracks or blisters). Driving with tyres in this condition can result in

blown tyres, accidents and severe injuries. Worn or damaged tyres must be replaced immediately.

- Never exceed the top speed and load permitted for the fitted tyres.
- The effectiveness of the driver assist systems and brake assist systems depends on the tyre grip.
- If you notice unusual vibrations or if the vehicle pulls to one side when driving, stop the car immediately and check the wheels and tyres for damage.
- Do not use wheels or tyres if you do not know their previous history. Used wheels and tyres could be damaged, even if the damage is not visible.
- Old tyres – even if never used – may lose pressure or burst, especially at high speeds, and thus cause accidents and severe injuries. Avoid using tyres that are more than six years old. If you have no alternative, drive slowly and with extra care at all times.

Handling wheels and tyres

📖 Please refer to ⚠️ at the start of the chapter on page 233.

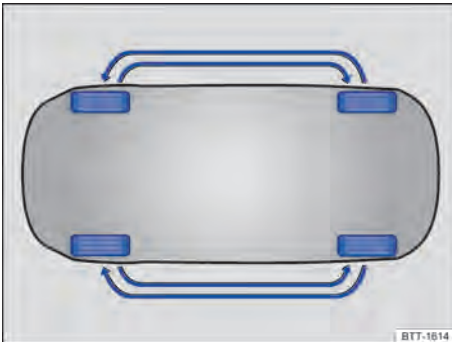

Fig. 192 Diagram showing how to swap wheels.

Tyres and wheel rims are an essential part of the vehicle's design. Tyres and wheels approved by Volkswagen are specifically matched to the characteristics of the vehicle and make a major contribution to good road holding and safe handling.

Rotating wheels

A regular rotation of the wheels as shown in the illustration → Fig. 192 is recommended to ensure a uniform level of wear for the tyres. All the tyres will then last for about the same time.

Volkswagen recommends to check the need to rotate the tyres at every servicing of the vehicle, and when there is such need, that alignment and balancing be performed.

Volkswagen recommends having the wheels rotated by a Volkswagen Dealership.

Avoiding damages to the tyres

- If you have to drive over a kerb or similar obstacle, drive slowly and at a right angle if possible.
- Inspect the tyres regularly for damage such as cuts, cracks or blisters.
- Remove foreign objects that are in the outer tyre tread and **have not penetrated the inner tyre** → page 238.
- Worn or damaged tyres must be replaced immediately → page 238.
- Regularly check the tyres for hidden damage → page 238.
- Never exceed the top speed and load permitted for the fitted tyres → page 240.
- Protect the wheels, including the spare wheel, from contact with corrosive substances, including oils, lubricants, fuel and brake fluid → ⚠️.
- Replace missing valve caps immediately.

Tyres older than 6 years

Tyres age through physical and chemical processes which can impair their function.

Volkswagen recommends replacing tyres older than 6 years with new tyres. This also applies to tyres, including the spare wheel, which appear to still be in good condition and on which the tread depth has not yet reached the minimum value provided by law → ⚠️.

The age of each tyre can be determined from the manufacturing date → page 240.



Storing tyres

Mark tyres before you remove them to ensure you will be able to mount them correctly when replacing (left, right, front, rear). When removed, ▶

the wheels or tyres should be stored in a cool, dry and preferably dark place. **Do not** vertically store tyres mounted on the wheels.

Tyres without wheels should be protected against dirt and stored in proper covers standing on the tread.

New tyres

- Drive particularly carefully for the first 600 km with new tyres, as the tyres have to be *run in*. Tyres that have not been run in have reduced grip →  and braking effect → .
- All 4 wheels must be fitted with radial tyres of the same type, size (rolling circumference) and the same tread pattern.
- The tread depth of new tyres may differ from manufacturing and profile modelling characteristics according to the type and make of tyre and the tread pattern.

Replacing tyres

- Tyres should be replaced at least in pairs and not individually (e.g. both front tyres or both rear tyres together) → .
- Old tyres should only be replaced by new tyres that have been approved by Volkswagen for the vehicle type. Ensure that the tyres used are correct in respect of size, diameter, load-carrying capacity and maximum speed.
- Never use tyres with an effective size that is larger than Volkswagen-approved tyres. Larger tyres could rub against the body or other parts of the vehicle.

Reprogram the tire control indicator

After each change of a wheel or several wheels, the tyre pressure loss indicator must be reset again. This is also valid when rotating front versus rear wheels → page 231.

Vehicles with tyre Pressure Monitoring System

When replacing the factory installed wheels, ensure that the new wheels are equipped with sensors compatible with the tyre pressure monitoring system → page 231. To have the new wheels recognized by the system, the vehicle must be driven for some time at speeds above 25 km/h.

At the time of replacement and change of the sensors, Volkswagen always recommends the installation of a new set of valves or caps

More information on the Tyre Pressure Monitoring System → page 231.

WARNING

Corrosive liquids and other substances can cause visible and invisible damage to the tyres, which can cause the tyre to burst.

- Always keep chemicals, oils, lubricants, fuel, brake fluid and other corrosive substances away from the tyres.

WARNING

New tyres will have to be run in, as they will initially have reduced grip and braking effect.

- Drive particularly carefully for the first 600 km in order to prevent accidents and severe injuries.

WARNING

Wheels must have the proper necessary freedom of operation. If the wheels do not have the necessary freedom of operation, the tyre could rub on parts of the running gear, the vehicle body and the brake system. This can lead to a fault in the brake system and to tread separation and thus to a tyre bursting.

- The actual tyre size must not exceed the tyre dimensions of manufacturers approved by Volkswagen and must not rub on any vehicle body parts.

NOTICE

Avoid strong shocks and, if possible drive around the obstacles. The tyres may get deformed, especially by holes in the road and bumping into the sidewalk guides. That may cause damages to the tyres and wheel rims.

 Old tyres must be disposed of with specific technical knowledge and equipment, based on specific standards. Therefore, we recommend visiting a Volkswagen Dealership or qualified workshop for such purpose.

 Tyre disposal requires equipment and knowledge of applicable environment protection standards. Tyres cannot be disposed / discarded along with common trash. Applicable laws establish specific disposal procedures for these cases. For your safety and convenience, Volkswagen recommends replacing tyres at a Volkswagen Dealership. ▶

i Despite identical size details, the actual size of the various tyre makes may vary from these specified dimensions, or the tyre contours may vary considerably.

i Volkswagen-approved tyres are guaranteed to have the dimensions that are suitable for the vehicle. The salesperson will have to provide a certificate from the tyre manufacturer for other tyre makes to prove that the tyre is also suitable for the vehicle. This certificate must be stored in a safe place within the vehicle.

- Manufacture date
- Country of origin
- Manufacturing number
- Raw material
- Part code

⚠ WARNING

The use of improper or damaged wheels can impair vehicle safety and cause accidents and severe injuries.

- Only use wheels which have been approved for the vehicle.
- Check the wheels regularly for damage and replace as necessary.

Wheels

📖 Please refer to ⚠ at the start of the chapter on page 233.

The design of the wheel bolts is matched to the wheels. If different wheels are fitted, the correct wheel bolts with the right length and properly shaped bolt heads must be used. This ensures that the wheels are fitted securely and that the brake system works properly → page 244.

For technical reasons, it is not generally possible to use the wheels from other vehicles. This can also apply to wheels of the same vehicle type.

Tyres and wheels approved by Volkswagen are specifically matched to the characteristics of the vehicle and make a major contribution to good road holding and safe handling.

Wheel bolts

Wheel bolts must always be tightened with the correct tightening torque → page 244.

Wheels with bolted-on trims

Wheels may have removable trims which are attached to the wheel with self-locking bolts. Damaged trims may only be repaired by a qualified workshop. Volkswagen recommends using a Volkswagen Dealership for this purpose.

Wheel identification

Due to legal requirements in some countries, the information on new wheels may contain some specific wheel features. The following wheel data may be available, depending on the country:

- Seal of conformity
- Rim size
- Manufacturer or brand name

Tyre pressure

📖 Please refer to ⚠ at the start of the chapter on page 233.

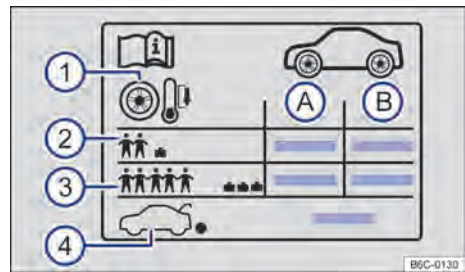

Fig. 193 Sticker with the tyre pressures.



Fig. 194 On the inner side of the fuel tank flap: tyre pressure label.

Indications on the tyre pressure sticker
→ Fig. 193:

- A** Tyre pressures for the front axle tyres.
- B** Tyre pressures for the rear axle tyres.

- ① Guideline: regularly check the pressure on the cold tyres.
- ② Tyre pressure under partial load.
- ③ Tyre pressure under full load.
- ④ Emergency wheel tyre pressure.

The sticker only indicates the correct tyre pressures for approved tyres and is located on the inside of the tank flap → Fig. 194.

According to the version of the vehicle the appearance of the sticker may vary. Additional tyre sizes may be contained → page 240.

If the tyre pressure is too low or too high, the tyres will wear prematurely and the vehicle will not handle well → ⚠. Proper tyre pressure is particularly important at **high speeds**. Incorrect tyre pressure causes premature wear and can cause tyres to burst.

Checking tyre pressure

The tyre pressure should only be checked if the tyres have not been driven for more than just a few kilometres at low speed in the last 3 three hours.

- Check tyre pressures regularly, at least every 15 days, and, additionally, prior any longer trip.
- Check the tyre pressures only on cold tyres. The indicated tyre pressures are valid only for **cold tyres**. Tyre pressure is always higher in warm tyres than it is in cold tyres. Therefore never release the air of hot tyres to adjust their pressure.
- Always adjust the tyre pressures to the vehicle load condition → Fig. 193 ③.
- After adjusting the tyre pressures, make sure to put the valve caps back on and to follow the instructions regards the tyre pressure monitoring system → page 231.
- Calibrate the tyres always to the pressures indicated on the sticker. Never exceed the maximum allowable pressure of the tyres as indicated on the tyre sidewalls.

⚠ WARNING

A tyre pressure that is too high or too low may cause the tyre to suddenly lose pressure or burst while the vehicle is in motion. This could lead to severe accidents and fatal injuries.

- Low tyre pressure may cause the tyres to heat to such an extent that the tread peels off and the tyre bursts.

- Fast speeds or overloading of the vehicle can cause overheating, sudden tyre damage including tyre bursts and ripping of the tread surface and thus to a loss of control of the vehicle.
- Check tyre pressures regularly, at least twice a month, and before every long journey.
- All tyres must have the correct tyre pressure to suit the vehicle load.
- Never reduce excess pressure when the tyres are warm.

ⓘ NOTICE

- When attaching the tyre pressure gauge, make sure that it does not touch the valve shaft. Otherwise, this could damage the tyre valve.
- Missing valve caps, or valve caps which are not suitable or not screwed on properly, may damage the tyre valve. Always use valve caps that comply with the factory-fitted valve cap specifications. Always screw on valve caps fully.

 Under-inflated tyres will increase fuel consumption. ◀

Tread depth and wear indicators

 Please refer to ⚠ at the start of the chapter on page 233.

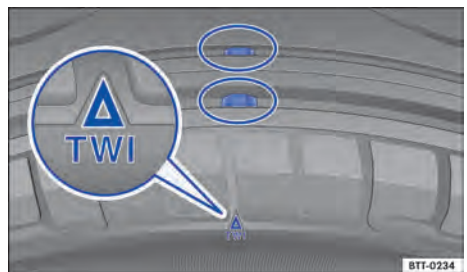



Fig. 195 Tyre profile: wear indicators.

Tread depth

In most countries, the minimum tread depth required by law is 1.6 mm (measured in the tread grooves next to the tread wear indicators). Observe any country-specific legal requirements. ▶

Difficult driving situations demand the deepest possible tread depth for the tyres and the same tread depth for the tyres on the front and rear axles → .

The tread depth of new tyres can vary according to type and manufacturer due to construction and tread design.

Observe the specific legal prescriptions of the country on the minimum tyre tread depth of winter tyres and regular tyres → page 242.

Tyre wear indicators

Tread wear indicators show if a tyre is worn down. The tyre must be replaced at the latest when the tread depth is just before the tread wear indicator.



The original tyres on your vehicle have 1.6 mm high tread wear indicators running across the tread → Fig. 195. These wear indicators are positioned at set intervals around the tyre. Markings on the tyre sidewall (for instance the letters "TWI" or other symbols indicate the positions of the tread wear indicators.

WARNING

Worn tyres threaten the safety of vehicle occupants and may cause loss of vehicle control and severe injuries.

- Tyres must be replaced at the latest when the tread is worn down to the tread wear indicators.
- Worn tyres have considerably less tread, particularly on wet roads, which can cause the vehicle to "glide" along the road surface (aquaplaning).
- Worn tyres reduce the possibility of controlling the vehicle well in normal and difficult driving situations and increase braking distance and the risk of sliding.

Tyre damage

 Please refer to  at the start of the chapter on page 233.

Damage to tyres and wheels is often not readily visible. Unusual **vibrations** or if the vehicle **pulls to one side**, one of the tyres might be damaged → .

- Reduce your speed immediately if you suspect that a wheel is damaged!
- Check the tyres and wheels for damages.
- If the tyre is damaged, do not drive on. Seek expert assistance.
- If there is no visible damage, drive slowly and cautiously to the closest Volkswagen Dealership or a qualified workshop in order to have the vehicle checked.

Foreign bodies in the tyre

- Leave the foreign body in the tyre if it has entered the inner tyre. However, foreign bodies that are stuck between the tyre tread blocks can be removed.
- Replaced the damaged wheel if necessary. Seek expert assistance if necessary. Volkswagen recommends using a Volkswagen Dealership for this purpose.
- Control and correct the pressure.

Tyre wear

Tyre wear is affected by several factors, such as:

- Driving style.
- Unbalanced wheels.
- Running gear setting.

Driving style – Fast cornering, heavy acceleration and hard braking all increase tyre wear. The running gear should be checked by a Volkswagen Dealership or qualified workshop if the tyres show excessive wear despite a normal driving style.

Unbalanced wheels – The wheels on new vehicles are balanced. However, various factors encountered in normal driving can cause them to become unbalanced, which results in steering vibration. Unbalanced wheels will affect levels of wear on the steering system and the suspension. In this case the wheels should be balanced again. New wheels must be balanced out prior mounting on the vehicle.

Running gear setting – incorrect wheel alignment causes excessive tyre wear, impairing the safety of the vehicle. The wheel alignment should be checked by a Volkswagen Dealership or qualified workshop if tyres show excessive wear. 

⚠ WARNING

Unusual vibrations or if the car pulls to one side while driving, one of the tyres might be damaged.

- Reduce speed immediately and park the vehicle while complying with traffic laws.
- Check the tyres and wheels for damages.
- Never drive on if the wheels or tyres are damaged. Seek expert assistance instead.

Spare wheel

📖 Please refer to ⚠ at the start of the chapter on page 233.



Fig. 196 On the luggage compartment: spare wheel fastening handwheel.

Removing the spare wheel

- Open the boot lid → page 69.
- If the case, lift and secure the variable luggage compartment floor → page 180.
- Lift the floor lining and remove it from the luggage compartment.
- Unscrew the handwheel in the middle of the spare wheel → Fig. 196 anticlockwise fully and remove the spare wheel.

Storing the removed wheel

- If necessary, place the vehicle toolkit back in the container in the luggage compartment.
- Place the removed wheel into the spare wheel well with the rim with the central hole in the rim positioned exactly above the stud.
- Turn the handwheel clockwise on the stud until the wheel is secured firmly.

- Reinsert the floor covering onto the top edge of the luggage compartment.
- If the case, close the variable luggage compartment floor → page 180.
- Close the boot lid.

Case the temporary spare wheel is different from the installed wheels

If the spare wheel is different from the normal vehicle tyre version, for example, the former may be used only in case of emergency, temporarily and with due precautions → ⚠. Also see → page 245.

Refit the normal road wheel as soon as possible.

Observe the driving notes:

- Do not drive faster than 80 km/h (50 mph)!
- Avoid full acceleration, sudden braking and fast driving through bends in the road!
- Tyre pressure must be checked as soon as possible after fitting the spare wheel → page 237.

The temporary spare wheel tyre pressure must be checked together with the tyre pressures of the regular wheels at least every 15 days → page 236.

⚠ WARNING

Incorrect use of the spare wheel or temporary spare wheel can lead to a loss of control of the vehicle, to collisions or other accidents and cause serious injuries.

- Never use a spare wheel or temporary spare wheel if it is damaged or worn down to the tread wear indicators.
- On some vehicles, the emergency spare wheel may be of a different size from the other wheels and tyres → page 245, *Temporary spare wheel of different size from the regular wheels*. Different sized emergency spare wheels are identified by an adhesive label and by the “80 km/h” inscription. This marking indicates the maximum rolling speed of the tyre.
- Never exceed 80 km/h (50 mph). Avoid full acceleration, sudden braking and making turns at high speeds!
- Replace the spare wheel with a regular wheel as soon as possible. The spare wheel is only intended for use in short periods of time.

- The temporary spare wheel must always be secured firmly with the wheel bolts supplied by the factory.
- Never overuse a spare wheel.

- After fitting the temporary spare wheel, the tyre pressure must be checked as soon as possible → page 236, *Tyre pressure*.

i If possible, firmly fasten the spare wheel or replaced wheel in the luggage compartment. ◀

Tyre markings and types

📖 Please refer to **▲** at the start of the chapter on page 233.

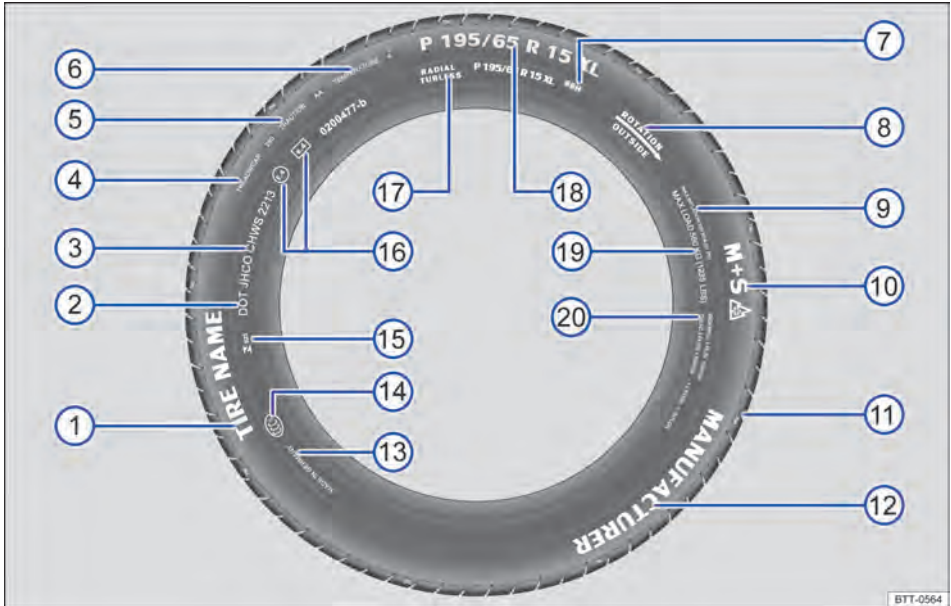





Fig. 197 International tyre lettering (example).

→ Fig. 197	Tyre lettering (example).	Definition
①	Product name	Individual tyre lettering from the manufacturer.
②	DOT	The tyre complies with the legal requirements of the Department of Transportation, responsible for tyre safety standards.
③	JHCO CHWS 2213	Tyre identification number (TIN^a - in some cases only on the inner side of the wheel) and manufacturing date:
	JHCO	Tyre manufacturing origin identification code
	CHWS	and manufacturer information regarding tyre size and features.
	2213	Manufacture date 22nd week of 2013.

Information for the end user concerning comparative values for specified basic tyres (standardised test procedure) → page 265: ▶

→ Fig. 197 Tyre lettering (example).		Definition
④	TREADWEAR 280	Relative life expectancy for the tyre, based on a standard test. Tyres with a treadwear of 280 wear out 2.8 times slower than regular tyres with a treadwear of 100. Tyre performance varies depending on use conditions and may significantly vary from standard values due to driving behavior, maintenance, different road characteristics and weather conditions.
⑤	TRACTION AA	Wet braking response of the tyre (AA, A, B or C). This rating is measured in certified test tracks, under controlled conditions. Tyres marked with C have low traction power. The traction rating assigned to the tyre is based on levelled track tests and does not include acceleration, lateral curves, aquaplaning, or traction under maximum load.
⑥	TEMPERATURE A	Temperature stability of the tyre at higher test speeds (A, B or C). Tyres marked with A and B exceed legal requirements. The temperature test is based on tyres with the proper pressure and excludes excess pressure. Excessive speeds, improper or excess tyre pressure may heat or damage the tyres, either separately or in combination.
⑦	88 H	Load → page 242 and speed index → page 242.
⑧	Rolling direction and arrow OR: Outside	Identification of the tyre's rolling direction → page 242. Identification of the tyre's outer wall → page 242.
⑨	MAX INFLATION 350 KPA (51 psi / 3,51 bar)	US maximum air pressure limitation.
⑩	M+S or M/S or 	Denotes winter tyres (mud and snow tyres). Spiked tyres are identified with an E after the S.
⑪	TWI	Indicates the position of the Tread Wear Indicator → page 237.
⑫	<i>Brand name, logo</i>	Manufacturer.
⑬	Made in Germany	Manufacturing country.
⑭		Specific identification for China (China Compulsory Certification).
⑮	 023	Specific identification for Brazil.
⑯	E4 e4 0200477-b	Certification of conformity with international requirements with the number of the country that issued the approval. Tyres approved as per ECE regulations are marked with E, and tyres approved as per EG regulations are marked with e. This is followed by the multi-digit approval number.
⑰	RADIAL TUBELESS	Tubeless radial tyre.
⑱	P 195 / 65 R 15 XL	Size designation:
		P Identification for passenger vehicle.
		195 Tyre width from wall to wall in mm.
		65 Height/width ratio in %.
		R Tyre construction: radial.
		15 Wheel diameter in inches.
XL Heavy-duty tyres ("Reinforced").		

→ Fig. 197	Tyre lettering (example).	Definition
19	MAXIMUM LOAD 615 KG (1235 LBS)	US maximum load rating per wheel.
	SIDEWALL 1 PLY RAYON	Indications on the components of the inner structure of the tyre: 1 Rayon layer (artificial silk).
20	TREAD 4 PLIES 1 RAYON + 2 STEEL + 1 NYLON	Tread component indications: In this example, there are 4 layers under the tread: 1 layer of Rayon (synthetic silk), 2 layers of steel strap and 1 layer of nylon.

a) TIN is the tyre serial number.

Tyres with directional tread pattern

Tyres with directional tread pattern have been developed to roll in a single direction. An arrow on the tyre sidewall indicates the direction of rotation on tyres with directional tread. The direction of rotation must be followed. This is the only guarantee for optimum grip and helps to avoid aquaplaning, excessive noise and wear.

If, however, the tyre is fitted in the opposite direction to the tread pattern, you must take more care when driving as the tyre is now no longer being used according to its designation. This is particularly important on wet roads. Tyres must be replaced as quickly as possible or be fitted with the tread in the correct direction.

Tyre load capacity

The load capacity index indicates how many kilograms can be loaded onto an individual tyre (tyre load).

80	450 kg
85	515 kg
90	600 kg
91	615 kg
93	650 kg

95	690 kg
97	730 kg
99	775 kg
100	800 kg

Speed index

The speed index indicates the maximum permitted speed that may be driven when particular wheels are fitted.

P	max. 150 km/h
Q	max. 160 km/h
R	max. 170 km/h
S	max. 180 km/h
T	max. 190 km/h
U	max. 200 km/h
H	max. 210 km/h
V	max. 240 km/h
W	max. 270 km/h
Y	max. 300 km/h

Some tyre manufacturers use the code "ZR" for tyres with a highest permitted speed of over 240 km/h (149 mph). ◀

Winter tyres

📖 Please refer to ⚠ at the start of the chapter on page 233.

In winter road conditions winter tyres will considerably improve the car's handling. The design of summer tyres (width, rubber compound, tread pattern) gives less grip on ice and snow. Volkswagen urgently recommends the use of winter tyres or all-year tyres on all 4 wheels of

the vehicle, particularly if winter conditions are expected on the roads. Winter tyres will also improve the braking response of the vehicle and will help to reduce braking distances in winter weather. At temperatures below +7 °C (+45° F) Volkswagen recommends that winter tyres be fitted to the vehicle. ▶

lose a large degree of their effectiveness when the **tread** is worn down to a depth of 4 mm. Winter tyres also largely lose their effectiveness through **ageing** – regardless of the remaining tread depth.

The following applies when using winter tyres:

- Observe any country-specific legal requirements.
- Use winter tyres on all 4 wheels at the same time.
- Only use in winter road conditions.
- Only use the sizes of winter tyre that have been approved for the vehicle.
- Winter tyres must have the same type, size (rolling circumference) and the same tread pattern.
- Observe the maximum speed permitted by the speed index → .

Speed limit

Winter tyres have a speed limitation depending on the speed index → page 242.

If you use **V-rated winter tyres**, the speed limits and tyre pressure depend on the motorization. You must ask your Volkswagen Dealership about the highest permitted speed and required tyre pressure.

WARNING

Improved driving conditions due to the use of winter tyres during winter weather does not mean safety risks must not be prevented.

- Adapt your speed and driving style to suit visibility, weather, road and traffic conditions.
- Never exceed the maximum speed and load limits for fitted winter tyres.

 Reassemble summer tyres only after the winter season is over. At temperatures above +7° C (+45° F) vehicle handling is better with summer tyres fitted. They are quieter, do not wear so quickly and reduce fuel consumption.

 On vehicles with tyre pressure loss indicator, the system needs to be reset after each wheel change → page 231.

 Volkswagen Dealerships can provide details on permissible winter tyre sizes. 

Hub caps

Wheel cover



Fig. 198 Remove the wheel cover.

Remove the wheel cover

- Take the lug wrench from the vehicle toolkit → page 194.
- Remove the wheel bolts. The bolt opposite to the valve → Fig. 198 (A) serves as a guide in the fitting sequence. Therefore, remove bolt (A) last and be careful not to let the wheel cover fall off when removing the remaining bolts.

Install the wheel cover

Fit bolt (A) first; position the wheel cover and fit the remaining bolts.

WARNING

Using unsuitable hubcaps and fitting the hubcaps incorrectly can cause accidents and severe injuries.

- Hub caps which are not fitted properly could become loose while the vehicle is in motion and endanger other road users.
- Do not use damaged hub caps.
- Always ensure that the flow of air to cool the brakes is not restricted or reduced. This also applies when retrofitting wheel trims. If the flow of air is not sufficient, the braking distance could increase significantly.

NOTICE

Remove hub caps carefully and fit them again properly so as to avoid damage to the vehicle. 

NOTICE

The wheel cover is secured to the wheel and cannot be removed without first removing the wheel bolts.



Wheel bolt cap



Fig. 199 Removing the wheel bolt caps.

According to the version of the vehicle, wheel bolt caps may not be available.

The caps protect the wheel bolts and must be fully fitted back after changing the wheel.

Removing and fitting the protection caps

- **Removing:** take the puller hook from the vehicle toolkit → page 194.
- Insert the puller hook into the opening of the bolt protection cap → Fig. 199 and pull off in the direction indicated by the arrow.
- **Installing:** insert the cover cap until the stopper on the wheel bolts.



Changing a wheel

Introduction

Only change the wheel yourself when the car is parked in a safe place, you are familiar with the necessary actions and safety procedures and you have access to all the correct tools! Seek expert assistance if this is not the case.

WARNING

Changing a wheel can be dangerous, especially when carried out at the side of a road. Please note the following points in order to reduce the risk of serious injuries:

- Stop the vehicle as soon as possible in a safe location. Park the vehicle at a safe distance from moving traffic in order to carry out the wheel change.
- All passengers, especially children, must be at a safe distance and away from your area of work during the wheel change.
- Switch on the hazard warning lights and set up the warning triangle to warn other road users.
- Make sure that the ground is flat and firm. If necessary use a large, strong board or similar support for the vehicle jack.
- Only change the wheel yourself if you feel confident carrying out the procedure. Seek expert assistance if this is not the case.
- Always use suitable and undamaged tools to change the wheel.
- Always switch off the engine, firmly apply the handbrake and, with an automatic gearbox move the selector lever to position P or engage a gear on a manual gearbox to reduce the risk of the vehicle moving.
- The wheel bolt tightening torque should be checked with a torque wrench immediately after changing a wheel.
- On vehicles with tyre pressure loss indicator, the system needs to be reset after each wheel change → page 231.



Preparations for changing a wheel

📖 Please refer to ⚠ at the start of the chapter on page 244.

Checklist

The following actions must always be carried out in the given order in preparation for changing the wheel → ⚠:

1. In case of flat tyres, park the vehicle at a safest distance possible from the traffic flow, in a steady and even terrain.
2. Apply the handbrake → page 121.



Checklist (Continued)



3. Automatic gearbox: move the selector lever to position **P** → page 111.
4. Stop the engine and remove the key from the ignition lock → page 104.
5. Manual gearbox: select the gear → page 110.
6. Have all occupants get out of the vehicle and placed in a safe spot away from the traffic.
7. Place a wedge on the opposite wheel, using a rock or similar object.
8. While towing trailers: unhitch the trailer from the vehicle and park it properly.
9. While the luggage compartment is loaded: remove baggage items.
10. Remove the spare wheel and the vehicle toolkit from the luggage compartment.
11. Remove the hub cap → page 243 and loosen the wheel screws.

WARNING

Ignoring any of the points on this important safety checklist can lead to accidents and injuries.

- Always follow the instructions on the checklist and comply with applicable safety precautions.

Temporary spare wheel of different size from the regular wheels

 Please refer to  at the start of the chapter on page 244.

On vehicles equipped with 15, 16, 17 and 18-inch wheel rims, the temporary spare wheel has a wheel rim of different dimensions from the regular wheel rims.

Apart from a different sized wheel rim, the vehicles equipped with light alloy wheels may have a temporary spare wheel of steel.

The temporary spare wheel must be used temporarily, replacing a 15-inch wheel, only for as long as necessary before having the regular wheel or tyre repaired → .

During this period, mind the following precautions: after installing a temporary spare wheel of different dimensions, the tyre pressure must be checked and adjusted, if necessary. Check proper

pressure values on the inside of the fuel tank cover. On vehicles with tyre pressure loss indicator, the system needs to be reset after each wheel change → page 231.

The different sized wheel must return as soon as possible to its initial condition, after the reinstallation of the regular wheel and tyre, repaired or replaced. Additionally, consider the maximum load capacity, specified in the tyre sidewall.

To reduce the chances of damages to the tyres and wheelrims of your vehicle:

- Avoid driving on roads with holes, depressions or bumps. The impacts suffered when running over obstacles such as these can damage your vehicle's tyres and wheel rims. If it is necessary to drive under such conditions, it is absolutely necessary to check the vehicle's tyres and wheel rims afterwards, or seek the assistance from a nearby Volkswagen dealership or specialized outfit.
- Perceiving any damage to the tyre it is necessary to replace it as soon as possible as there is a risk of the tyre blowing up and loss of control over the vehicle.

WARNING

Incorrect use of the temporary spare wheel of different wheel rim dimensions for an extended period of time, or by permanent replacement of the 15, 16, 17 and 18-inch wheel rims, may result in vehicle control loss, collisions or other accidents with risk of severe injuries.

- Never drive at speeds in excess of 80 km/h while using the different sized temporary spare wheel rim. Avoid sudden brakes or acceleration, as well as steep curves.
- Never use more than one different sized wheel rim at the same time.

Wheel bolts

📖 Please refer to ⚠ at the start of the chapter on page 244.



Fig. 200 Changing the wheel: loosen wheel bolts.

Only the spanner delivered with the vehicle should be used to loosen the wheel bolts.

Only loosen the wheel bolts by approximately one turn before raising the vehicle with the vehicle jack.

If the wheel bolt is very tight, you may be able to loosen it by pushing down the end of the spanner carefully with your foot. Hold on to the car for support and take care not to slip.

Loosening the wheel bolts

- Fit the box spanner over the wheel bolt as far as it will go → Fig. 200.
- Hold the end of the box spanner and turn the wheel bolt approximately *one* turn anticlockwise → ⚠.

Important information about the wheel bolts

The wheel bolts were specifically designed for the factory-fitted wheels. If different wheels are fitted, the correct wheel bolts with the right length and properly shaped bolt heads must be used. This ensures that the wheels are fitted securely and that the brake system works properly.

Tightening torque for the wheel bolts

Prescribed tightening torque for light alloy wheel rims and steel wheel rims:

- 120 Nm

If the wheel bolts are corroded and difficult to turn, they must be replaced and the wheel hub threads cleaned **before the tightening torque is checked**.

Never grease or lubricate the wheel bolts or the threads of the wheel hub. This could cause them to loosen while the vehicle is in motion, even if the required torque setting is used.

The tightening torque should be checked with a torque wrench immediately after changing a wheel.

⚠ WARNING

Incorrectly tightened wheel bolts can loosen while the vehicle is in motion and cause accidents, serious injury, and loss of control of the vehicle.

- Only use wheel bolts corresponding to the respective wheel.
- Never use different wheel bolts.
- The wheel bolts and threads of the wheel hubs must be clean, free from oil and grease, and turn easily.
- Always use the box spanner placed in the vehicle at the factory to loosen and tighten the wheel bolts.
- Only loosen the wheel bolts by approximately one turn before raising the vehicle with the vehicle jack.
- If the tightening torque of the wheel bolts is too low, the wheel bolts and wheels can loosen while the vehicle is in motion. The wheel bolts and threads can be damaged if the tightening torque is too high.

Lifting the vehicle with the jack

📖 Please refer to ⚠ at the start of the chapter on page 244.



Fig. 201 Jacking points

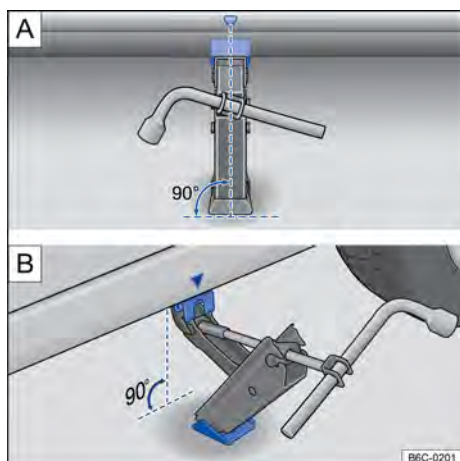

Fig. 202 Jacking points and vehicle jack at the rear left-hand side of the vehicle.

The jack may be applied only at the jacking points shown (markings on the body) → Fig. 201. Always use the jacking point closest to the wheel you are working on → ⚠.

Checklist

To ensure your own safety and the safety of your passengers, observe the following points in the order given → ⚠:

1. Find a flat and firm surface suitable for lifting the vehicle.
2. Turn the engine off, engage a gear → page 110, when manual gearbox or, move the selector lever to position **P** → page 111, when automatic gearbox, and apply the handbrake → page 121.
3. Ensure that all passengers leave the vehicle.
4. Place a wedge on the opposite wheel, using a rock or similar object.
5. While towing trailers: unhitch the trailer from the vehicle and park it properly.
6. Loosen the wheel bolts on the wheel that is being changed → page 246.
7. Find the jacking point under the vehicle → Fig. 201 closest to the wheel that is being changed.
8. Insert the tip of the wrench in the jack and hold the wrench by the hexagonal end.
9. Raise the vehicle jack until it just fits under the jacking point of the vehicle.
10. Ensure that the entire surface of the foot of the jack is resting securely on the ground and that the foot of the vehicle jack is positioned precisely below the jacking point → Fig. 202 **A** and **B**.
11. Position the vehicle jack. At the same time, continue to crank the claw up until it is in position around the vertical rib underneath the vehicle → Fig. 202 **A** **B**.
12. Crank the vehicle jack further until the wheel is just clear of the ground.

⚠ WARNING

Incorrect use of the vehicle jack can cause the vehicle to slip, which can lead to severe injuries. Please apply the following rules to reduce the risk of accidents:

- Only use jacks which have been approved by Volkswagen for the vehicle. Other vehicle jacks could slip out of position – this includes vehicle jacks supplied with other Volkswagen models.

- The ground must be flat and firm. Tilted or unstable surfaces can cause the vehicle to slide. If necessary use a large, strong board or similar support for the vehicle jack.
- On a hard, slippery surface (such as tiles) use a rubber mat or similar to prevent the vehicle jack from slipping.
- Fit the vehicle jack only at the points described. The vehicle jack claw must grip the vertical rib under the sill securely → Fig. 202 A and B.
- When towing a trailer, unhitch the trailer from the traction vehicle before changing the wheel.
- Never place any part of your body (e.g. arm or leg) underneath the vehicle if the latter is only supported by the vehicle jack.
- Ensure that all passengers leave the vehicle.
- If you have to work underneath the vehicle, use suitable stands to provide extra support.
- Never lift the vehicle while the engine is running or if the vehicle is parked over a slope surface.
- Never start the engine when the vehicle is raised on a vehicle jack. Engine vibrations can cause the vehicle to fall off the vehicle jack.

! WARNING

Ignoring any of the points on this important safety checklist can lead to accidents and injuries.

- Always follow the instructions on the checklist and comply with applicable safety precautions.

Changing the wheel

📖 Please refer to ⚠ at the start of the chapter on page 244.



Fig. 203 Wheel replacement: wheel bolt removal sequence.

Removing the wheel

- Read the checklist → page 244.
- Loosen the wheel bolts → page 246.
- Lift the vehicle → page 247.
- Completely remove the loose wheel bolts (A) using the wheel wrench and place them on a clean surface.
- **On vehicles with wheel covers**, the bolt opposite to the valve → Fig. 203 (A) serves as a reference in the installation sequence. Therefore, remove bolt (A) last and be careful not to let the wheel cover fall off when removing the remaining bolts.
- Remove the wheel.

Install spare wheel

If applicable, take note of the running direction of the tyre → page 231.

- Insert the spare wheel.
- **On vehicles with wheel covers**, fit bolt → Fig. 203 (A) first; position the wheel cover and install the remaining bolts.
- Position the wheel bolts and tighten them *slightly* with the wheel wrench.
- Lower the vehicle with the jack.
- Use the box spanner to tighten all the wheel bolts securely → ⚠. Do not tighten the bolts in clockwise or anticlockwise sequence. Tighten them in diagonal sequence. ▶

WARNING

An incorrect torque or incorrectly handled wheel bolts can lead to a loss of control of the vehicle, cause accidents and serious injuries.

- Always keep all wheel bolts and threads in the wheel hubs clean and free from oil and grease. Wheel bolts must be easy to turn and be tightened to the specified torque.





Wheel bolts must be clean and able to turn freely. Never lubricate wheel bolts.



When changing wheels, if you notice that the bolts are corroded or worn, they must be replaced before checking the tightening torque.

After changing a wheel

 Please refer to  at the start of the chapter on page 244.

- Clean the tools as necessary and place them back in the luggage compartment → page 194.
- Stow the spare wheel or the removed wheel securely in the luggage compartment.
- The tightening torque of the wheel bolts should be checked immediately with a torque wrench
- The damaged wheel should be replaced as soon as possible.

WARNING

After changing the wheel, always ensure that the vehicle toolkit and spare wheel are properly secured in the luggage compartment.



On vehicles with tyre pressure loss indicator, the system needs to be reset after each wheel change → page 231.

Maintenance

Service

Maintenance services and digital maintenance and warranty

The **vehicle data label** on the back cover of this instruction manual confirms the **initial release or delivery date, the delivery inspection** and thus the start of the warranty coverage for your vehicle.

For some markets the digital Maintenance and warranty is not available. In this case your Volkswagen Dealership will be able to inform you about its service and documentation.

Digital electronic registration of maintenance services performed

Service vouchers will be stored in the central system memory by the Volkswagen Dealership or specialized company. Through this transparent service history documentation, performed vehicle maintenance work can be accessed at any time. Volkswagen recommends requesting, after each service performed, a printed proof of service containing data on maintenance work stored in the system.

With each new service, the previous proof of service is replaced by an updated printout.

Service

Digital Maintenance and warranty records the following information from your Volkswagen Dealership or specialist company:

- When a given service was performed.
- Whether a repair recommendation was given, as for example, whether the brake pads will have to be replaced soon.
- Which components or fluids have been renewed.
- When your next service call will be due.



WARNING

Insufficient or not performed maintenance and failure to observe the service intervals may cause vehicle stops, traffic accidents, and serious injuries.

- Have the maintenance work performed by an authorized Volkswagen Dealership or qualified workshop.

 **NOTICE**

Volkswagen may not be held liable for damage to the vehicle due to insufficient service or missing parts.

 Regular vehicle maintenance services not only serve the purpose to maintain the value of the vehicle, but also contribute to operational and traffic safety. Servicing work should therefore always be carried out in accordance with the Volkswagen maintenance guidelines. 

First service

The servicing interval may be different according to the country.

Petrol engines

Service based on time or mileage

Oil Change Service

The service is carried out in accordance with the next servicing indicator, and according to which ever occurs first:

- after 1 year or every 10,000 km;
- after 1 year or every 15,000 km.

TOTALFLEX Engine

Service based on time or mileage

The service is carried out in accordance with the next servicing indicator, and according to which ever occurs first:

- after 1 year or every 10,000 km.

Information on the terms of use

The indicated service intervals are established based on **normal driving conditions**.

In case of **adverse driving conditions**, some intermediary services are required between each of the service intervals indicated.

Adverse driving conditions include the following cases:

- fuel with high sulphur content;
- frequent driving at low engine speeds with intense traffic, with extended periods operating at idling speed ("stop-and-go"; urban traffic),
- in short trajectories (below 8 km per day) or with the engine running below ideal temperatures;
- in urban routes with frequent stops;
- high ambient temperature associated to constant use of the air conditioning system
- frequent traffic in unpaved or dusty roads and highways.;
- predominant driving under environments with high levels of suspended particles (mining, cement, steelworks, marble, and saline factories, etc.),

- predominant operation towing trailers or transporting cargoes;
- vehicle operation to provide taxi services, school transportation, deliveries, special services (patrolling, escorting, ambulance, fire trucks, military use) and/or similar applications.

These conditions particularly affect the following parts:

- toothed belt;
- dust and pollen filter
- air filter,
- engine oil.

Your Volkswagen Dealership will inform you of any eventual need to perform intermediary services based on your vehicle driving conditions.

The costs of Volkswagen services may vary according to the vehicle model and equipment version, as well as additional services and inspections eventually required. Your Volkswagen Dealership will inform you of all costs (labour and material) regarding Volkswagen maintenance services.

Service scopes

Depending on the vehicle model/version, some of the scope items may not be available and/or be applicable to the vehicle.

The service scopes include all the necessary **maintenance items** to keep your vehicle in safe condition for driving and the traffic (depending on the conditions of use and the equipment of the vehicle such as for example, engine, transmission or fluids). The maintenance service work is split between *inspection items* and *maintenance items*. You can consult your Volkswagen Dealership for a detailed overview of the necessary activities .

Inspection items

Electric system

- Battery: check
- Horn: check
- Lighting (interior and exterior): check
- Service interval display: reset

Engine / Gearbox

- Poly V-belt: check
- Engine and engine compartment components (upper and lower parts): check
- Cooling system: check
- Exhaust system: check
- Power transmission and final drive system: check

Running gear

- Coil springs and elastic stops: check
- Protective joint hoods: check
- Electric power steering: check
- Swivel joints/track rods: check
- Brake fluid level: check
- Brake pads/discs: check
- Tyres: check
- Tyre pressure of all tyres: check
- Shock absorbers and brake system: check

Body

- Body: check for damages and corrosion
- Window wiper blades: check
- Windscreen: check
- Underside of the vehicle: check
- Window wiping and washing system: check
- Test drive: perform

Maintenance items

In addition to the inspection items (depending on the use and the vehicle's equipment, such as engine, power transmission or fluids), other maintenance items may have to be performed on your vehicle. These items must be looked after based on the *time* and/or *mileage*.

- Additives: change/fill up
- Toothed belt/toothed belt tensioning roller: check/ replace
- Poly V-belt: replace
- Air cleaner: replace
- Fuel filter: replace (only TOTALFLEX vehicles)
- Brake fluid: replace
- Dust and pollen filter: replace
- Engine: replace filter/oil
- Spark plugs: replace

There may be changes to the service scope for technical reasons (continuous components development). Volkswagen Dealerships are always updated about innovations. 

Vehicle conservation

Guidelines for the conservation of the vehicle

Regular and expert care helps to **maintain the value** of the vehicle. Proper maintenance may also be one of the requirements for the approval of warranty claims in the event of corrosion or paint defects.

Suitable care products are available from Volkswagen Dealerships.

WARNING

Car care products can be toxic and hazardous. Unsuitable care products and incorrect application of care products can cause accidents, severe injuries, burns or poisoning.

- Care products must be kept in its original sealed container.
- Read the manufacturer's instructions.
- Never store car care products in empty food containers, bottles or any other non-original containers as people finding these containers may not know that they contain care products.
- Keep children away from care products.
- The products may generate harmful fumes during use. Such products should therefore only be used outside or in well-ventilated spaces.
- Never use fuel, turpentine, engine oil, nail varnish remover or other volatile fluids to wash, clean or care for your vehicle. These substances are toxic and highly flammable.

WARNING

Incorrect care and cleaning of vehicle parts can impair the safety features of the vehicle and thus cause serious injuries.

- Vehicle parts must be cleaned according to the manufacturer's instructions. 

- Only use approved or recommended cleaning products.

NOTICE

Cleaning agents that contain solvents attack the material and can cause damage.

NOTICE

Never attempt to remove dirt, mud or dust from a dry vehicle surface. Additionally, never use dry cloths or sponges in order to prevent risking the vehicle paint or windows. Dirt, mud and dust must be softened with water before they are removed.

 Environmentally-friendly care products should be used.

 Leftover car care products should not be disposed of with common waste. Read the manufacturer's instructions.

Washing of the vehicle

The longer substances such as insects, bird droppings, resinous tree sap, road dirt, industrial deposits, tar, soot or road salt and other corrosive materials remain on the vehicle, the more damage they do to the paintwork. High temperatures and strong sunlight further intensify the corrosive effect. The **underside** of the vehicle must also be cleaned thoroughly on a regular basis.

Car washes

Please observe the signs on the automatic car wash. Before using an automatic car wash, take the usual precautions, such as closing all windows and folding in the exterior mirrors, in order to avoid vehicle damages. Inform the car wash operator if there are special parts on your vehicle such as spoilers, radio aerials → .

The paint is so hard-wearing that the car can normally be washed without problems in an automatic car wash. However, the effect on the paint depends to a large extent on the design of the car wash. Volkswagen recommends the use of car washes without brushes.

To remove any wax residues from the windows and to prevent windscreen wipers from rubbing, please follow the below guidelines → page 255, *Cleaning windows and exterior mirrors.*

High pressure washing machine

Follow the instructions provided by the manufacturer when cleaning your vehicle using a high-pressure cleaner. This applies in particular to the **pressure** and **spraying distance** → .

Washing the vehicle with a high-pressure cleaner may cause water to enter the vehicle. Avoid using high-pressure cleaners at distances lower than 30 cm from the vehicle's surface. Using a high-pressure cleaner of over 8,000 kPa (80 bar) could damage or remove paintwork or adhesives.

Maintain sufficient distance to soft materials such as rubber hoses, insulation, and the park distance control sensors. Parking distance control sensors are located in the rear bumper → .

Never use **concentrated jet nozzles** or **dirt blasters** → .

Washing the car by hand

◁ When washing by hand, first soften the dirt with plenty of water and rinse off as well as possible.

Then clean the vehicle with a soft **sponge**, a **glove** or a **brush**, using only light pressure. Start with the roof and work from the top to the bottom. Use a **shampoo** for very persistent dirt only.

The sponge or glove should be wrung out thoroughly at regular intervals.

Clean the wheels, sill panels etc. last. Use a different sponge for this purpose.

Vehicle paintwork conservation

Waxing protects the paintwork. As soon as water no longer forms **visible drops** on the *clean* paintwork it is time to protect it again with a good **car wax**.

Even when a **wax solution** is used regularly in the car wash, Volkswagen recommends protecting the paint with a coat of hard wax at least twice a year.

Polish the vehicle's paintwork

Polishing is only necessary if the paint has lost its shine, and the gloss cannot be brought back by applying wax.

The car must be waxed after polishing if the polish used does not contain wax compounds to seal the paint. ▶

WARNING

Parts of the vehicle with sharp edges may cause injuries.

- Protect your hands and arms from cuts on sharp parts, for example when cleaning the underbody or the inside of the wheel housings.

WARNING

After the car has been washed, the braking effect could set in later than normal and extend the braking distance as the brake discs and brake pads will be wet, or iced up in winter.

- “Dry the brakes and eliminate ice” through careful braking manoeuvres. Proceed without putting other drivers at risk or failing to abide by legal requirements.

WARNING

Incorrect use of a high-pressure cleaner can cause visible and invisible long-term damage to tyres and other materials. This could lead to accidents and severe injuries.

- Maintain sufficient distance between the nozzle and the tyres.
- Never clean the tyres with concentrated jet nozzles (“dirt blasters”). Even at large spraying distances and short cleaning times, visible and invisible damage can occur to the tyres.

NOTICE

- Water temperature should not be higher than +60 °C.
- Do not wash the vehicle in direct sunlight in order to avoid damage to the vehicle paintwork.
- The parking distance control sensors in the bumpers must be clean and free of ice to guarantee correct function. When cleaning with pressure hoses and steam cleaners, the sensors should only be sprayed briefly, always maintaining a distance of over 30 cm.
- Never clean with hard sponges, rough kitchen sponges or similar products as these can damage the surface.
- Do not clean windows that are iced over or covered in snow with a high-pressure cleaner.
- Never clean the headlights with a dry cloth or sponge. Soapy water is the preferred choice.

- Vehicle washing under cold weather: if the vehicle is rinsed with a hose, do not direct the water into the lock cylinders or the gaps round the doors, boot, or bonnet. The locks and seals could freeze.



NOTICE

Before using an **automatic washing system**, the following points must mandatorily be checked to prevent damages to the vehicle:

- Make sure that the gap between the guide rails in the car wash is sufficient to prevent damages in wheels and tyres!
- Check that the car wash is tall and wide enough for your vehicle.
- Fold in the exterior mirrors.
- In order to prevent damage to the paintwork on the engine compartment cover, fold the windscreen wipers back onto the windscreen after drying the wiper blades. Do not let them drop!
- Lock the boot lid to avoid unexpected opening in the automatic car wash.

NOTICE

- In order to avoid damage, painted parts with a matt finish, plastic parts, headlight lenses and the tail lights should not be treated with polish or hard wax.
- Do not polish the paint if the vehicle is in a sandy or dusty environment or if it is dirty.

 The vehicle should only be washed in specially provided wash bays. This prevents toxic, oil, grease and fuel laden waste water from entering the sewage system. In some regions, washing vehicles anywhere else may be prohibited. 

Cleaning and conserving the exterior of the vehicle

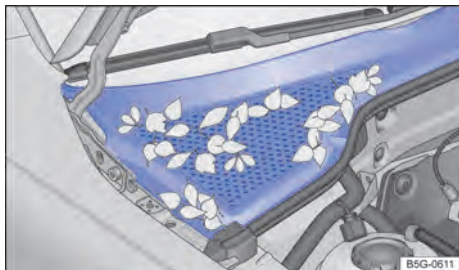

Fig. 204 Between the engine compartment and the windshield: plenum chamber (schematic representation).

Cleaning windows and exterior mirrors

Moisten the windows and exterior mirrors with standard alcohol-based glass cleaner.

Dry the glass surfaces with a clean chamois leather or a lint-free cloth. Chamois leathers which have been used on painted surfaces have grease residues and are therefore not suitable for use on glass surfaces.

Use window cleaner or a silicone remover to clean off rubber, oil, grease and silicone deposits → ⓘ.

Remove wax residues

Car washes and care products could leave **wax deposits** on the glass surfaces. Wax residue can only be removed using a special cleaning product or cleaning cloths. Wax residues can affect the window wiper system's performance, in addition to causing irregular movement or excessive noises. Volkswagen recommends using a glass cleaning cloth to remove wax deposits from the windows and exterior mirrors each time the vehicle is washed.

A window cleaner specifically for removing wax will stop the blades rubbing if added to the window washer water. Dilute the cleaner as instructed. Grease removing cleaners will not remove wax deposits → ⓘ.

Special cleaners, glass cleaners and glass cleaning cloths are available from Volkswagen Dealerships.

Remove the snow

Use a small brush to remove snow from the windows and exterior mirrors.

Remove the ice

The best method for removing ice is to use a de-icer spray. If you use an ice scraper, **do not** move it to and from, but push it in one direction only. Moving the ice scraper backwards can cause dirt to scratch the window.

Clean chrome and aluminium parts

- Use a damp, clean, lint-free and soft cloth to clean the surfaces.
- For heavy soiling use a special **solvent-free** cleaning product.
- Polish the chrome and aluminium trim parts using a soft and dry cloth.

Cleaning steel wheels

Use an industrial cleaner to remove brake dust caught in the wheel. Steel wheels should therefore be cleaned regularly with a separate sponge.

Any damage to the paint on steel wheels should be touched up before the metal starts to rust.

Caring for and cleaning alloy wheels

Wash grit and brake dust from alloy wheels approximately **every 2 weeks**. Then use an acid-free detergent to clean the wheels. Volkswagen recommends applying a hard wax compound to the wheels approximately **every 3 months**.

If the brake dust is not removed regularly, the alloy wheel could be damaged.

Always use an acid-free detergent for alloy wheels. Car polish or other abrasive agents should not be used on the wheels.

If the protective coating is damaged (e.g. by stone impact) the damaged area should be repaired immediately.

Conserve the rubber seals

The rubber seals on the doors, windows etc. will seal better, remain flexible and last longer if they are treated at regular intervals with a suitable care product.

Use a soft cloth to remove dust and dirt from the rubber seals before applying the product. ▶

Defrost the door lock cylinders

Volkswagen recommends the use of genuine Volkswagen spray with lubricating and anti-corrosive properties to de-ice the lock cylinders.

Protection of the underside of the vehicle

The underside of the vehicle is coated to protect it from corrosion and damage. The protective coating on the underside of the vehicle could be damaged when driving. Volkswagen recommends therefore that the protective coating on the underside of the vehicle and on the running gear should be checked regularly and repaired if necessary.

Hollow cavities

All hollow spaces exposed to corrosion are factory-fitted with long-lasting protective coating.

Such coating does not require maintenance. If, due to extremely high temperatures, a small amount of wax is melted, it may be removed using a plastic spatula and benzene.

Clean the engine compartment

The engine compartment of any motor vehicle is a hazardous area → page 213.

The engine compartment must be cleaned by a Volkswagen Dealership or qualified workshop. An incorrect cleaning procedure could possibly remove corrosion protection and damage electrical components, among others. Additionally, water could enter the vehicle interior directly via the plenum chamber → ⓘ.

If the engine compartment is very dirty, we recommend that you always go to a qualified workshop to have it cleaned following correct procedures. Volkswagen recommends using a Volkswagen Dealership for this purpose.

Plenum chamber

- The plenum chamber is located in the engine compartment between the windscreen and the engine and has a perforated cover → Fig. 204. Air from outside is drawn in from the plenum chamber and is passed into the vehicle interior via the heating and fresh air or the air conditioning system.
- Leaves and other loose items must be removed from the cover of the plenum chamber at regular intervals using a vacuum cleaner or by hand.

Sensors, rear view camera lens

Clean the area in front of the sensors or camera with a soft cloth and a cleaning product free of solvents. Observe the installation locations → page 8.

WARNING

Dirty or misted windows reduce visibility and increase the risk of accidents and severe injuries.

- Only drive when you have a clear view through all windows.
- Ice, snow and mist must be removed from the inside and outside of all windows.

WARNING

All work in the engine compartment carries the risk of injury, scalding, accidents and fire!

- Before carrying out any work make sure that you are familiar with the requisite procedures and general safety regulations → page 213, *Safety guidelines for work in the engine compartment*.
- Volkswagen recommends having the work carried out by a Volkswagen Dealership.

CAUTION

Underseal and anti-corrosion coatings may ignite on the hot exhaust system or on other hot engine parts.

- Never apply underseal or anti-corrosion coatings to the exhaust pipes, catalytic converter, heat shields or other vehicle components that become hot.

NOTICE

- Properly cleaning the windows enhances the window wiper system's performance and preservation.
- Never combine the recommended cleaning agents with other products in the window washer fluid reservoir. This may cause the components to coagulate and, as a result, clog the window wiper nozzles.
- Never use warm or hot water to remove snow and ice from windows and mirrors. This may cause the glass to crack!
- Never use ice scrapers on mirror lens, otherwise the chromed-coated surface will be scratched. ▶

- The heating elements for the rear window heater are located on the inside of the rear window. Never apply stickers over the heating elements and never clean the inside of the rear window with corrosive or acidic detergents or any other chemicals.

NOTICE

To ensure that the chrome and aluminium parts are not damaged:

- Do not clean or polish in direct sunlight.
- Do not clean or polish in sandy or dusty environments.
- Do not use any abrasive care products (e.g. cream cleaners).
- Never clean with hard sponges, rough kitchen sponges or similar products.
- Do not polish dirty surfaces.
- Do not use solvent-based cleaning products.
- Do not use any hard wax.

NOTICE

The wheel covers may also have an additional varnish finish and should not be treated using chrome based preservatives or aluminium polish. Regular paint care and standard cleaning products must be used instead.

NOTICE

Lock de-icers which contain substances which dissolve grease may cause the door lock cylinder to rust.

NOTICE

Water that has entered the plenum chamber via a manual process (e.g. from a high-pressure cleaner) can cause considerable damage to the vehicle.

 Before removing wax with benzene, comply with applicable safety and environment standards regarding such product.

 Considering that when washing the engine, toxic waste water containing oil, grease and fuel may enter the sewerage system, the contaminated water needs to be purified by an oil separator. Therefore, the engine compartment should only be washed in extreme cases and in appropriate locations.

Cleaning and conserving the interior of the vehicle

Modern fabrics, such as dark denim, are often not colourfast. Light-coloured upholstery (soft materials or leather) is particularly sensitive to staining caused by these fabrics, even if you are careful. This is not caused by a fault in the upholstery, but by the non-colourfast nature of the garments.

Leaving stains, dirt and other deposits on the surface of vehicle components and cloth seat covers for a long time can make it difficult to clean and treat them. Stains, dirt and deposits may become impossible to remove, particularly if left for a long time.

Seat covers

Please note the following for handling and conservation of the seat covers:

- Before getting into the vehicle, close all Velcro fasteners that could touch the cloth seat covers and fabric trims. Open Velcro fasteners can cause damage to cloth seat covers and fabric trims.
- Avoid the direct contact of sharp-edged items and accessories to the upholstery and fabric trims in order to prevent damage. Accessories include zips, studs, rhinestones on clothing or belts.
- Dust and grit in the pores and seams should be removed regularly so that no permanent damage is caused to the surface of the seats by scratching.
- Always check whether garments are colourfast to prevent damage to the upholstery. This is especially important for light-coloured upholstery.

Cleaning paddings, fabric and NT - Non microfiber fabric

- Please read and follow the instructions, notes and warnings on the package before using cleaning products.
- Upholstery, fabric trims, NT - non-microfiber fabric trims, and carpeting must be regularly cleaned with a vacuum cleaner (brush tip).
- Do not use high-pressure cleaners, steam cleaners or coolant spray.

- We recommend that you use a soft sponge or commercially available lint-free microfiber cloth for cleaning jobs → ⓘ.
- Clean NT - non-microfiber fabric surfaces with a slightly damp cotton or woollen cloth or a commercially available lint-free microfiber cloth → ⓘ.

General surface soiling of the upholstery and fabric trim can be cleaned with standard foam cleaners.

If the upholstery and fabric trims are generally heavily soiled, consult a Volkswagen Dealership for information on suitable cleaning methods before attempting any cleaning procedure. Take the vehicle to a specialist cleaning company, if necessary.

Padding, fabric and NT - Non microfiber fabric stain treatment

When cleaning stains, it may be necessary to clean the entire surface and not just the stain itself. This particularly applies if the surface shows general signs of wear. The cleaned area could otherwise be lighter than the surrounding area. If in doubt, consult a specialist cleaning company.

Water-based stains (e.g. coffee, fruit juice or soda).

First, clean the stain as quick as possible with a dry and absorbent cloth, to prevent the liquid from penetrating the upholstery. For more difficult stains, moisten the sponge with an atomizer and clean the stain with circular motions. Clean with a dry and absorbent cloth.

Stubborn stains, e.g. chocolate, make-up. Only use detergents that have been approved by Volkswagen. If necessary, take the vehicle to a specialist cleaning company.

Oily stains, e.g. oil, lipstick. Only use detergents that have been approved by Volkswagen. If necessary, take the vehicle to a specialist cleaning company.

Conservation and treatment of natural leather covers

Please contact a Volkswagen Dealership or qualified workshop if you have any questions on cleaning and caring for the leather equipment in your vehicle.

Natural leather is a sensitive material.

- Use a leather cream with sunlight protection and impregnation properties on a regular basis and always after cleaning. The cream nourishes the leather, keeps it breathable and supple and replaces lost moisture. It also protects the surface.
- Leather should be cleaned every two to three months to remove fresh stains.
- Treat the leather with a special leather care product every six months → ⓘ.
- Always apply cleaning and care products extremely sparingly and always use a dry cotton or woollen cloth that is lint free. Do not apply cleaning and care products directly to the leather.
- Remove fresh stains such as ink, ball-point pen ink, lipstick, shoe cream etc. as quickly as possible.
- Look after the pigment. Use a special coloured leather cream to refresh the colour where necessary.
- Wipe off excess with a soft cloth.

Cleaning natural leather covers

Volkswagen recommends that you use a damp cotton or wool cloth for general cleaning purposes.

Do not let the water soak through the leather or soak into the seams.

Please observe the following notes **before cleaning** the leather upholstery → page 257, *Cleaning paddings, fabric and NT - Non microfiber fabric.*

Stubborn stains – Spread the smooth soap solution¹⁾ with a twisted cloth. Absorb by pressing lightly with a dry cloth.

Water-based stains, such as coffee, tee, juice, blood, etc.

Remove the stains while they are still moist with an absorbent cloth. Use a cleaning product appropriate for already dried stains → ⓘ.

¹⁾ Smooth soap solution: two teaspoons of neutral soap in one litre of water.

Fat based stains, such as oil, lipstick, etc. Remove the stains while they are still moist with an absorbent cloth. Use a cleaning product appropriate for stains that have not yet penetrated the surface → ①.

Special stains, such as biro, felt tip pen, nail varnish, emulsion paint, shoe polish, etc. Dry with a dry and absorbent cloth. Clean with a special stain remover for leather.

Cleaning vinyl covers

Please observe the following notes before cleaning vinyl covers → page 257, *Cleaning paddings, fabric and NT - Non microfiber fabric.*

Only use water and neutral soap to clean vinyl covers.

Cleaning stowage compartments and drink holders

Some stowage compartments and cup holders have a removable rubber insert in the base.

- Moisten a clean, lint-free cloth with water and clean the parts.
- If this does not provide satisfactory results, use a special **solvent-free** plastic cleaning product.

Cleaning the ashtray

- Remove and empty the ashtray.
- Wipe the ashtray with a cloth.

To clean the snuffer, use a toothpick or similar object to pick out the ashes.

Conserving and cleaning plastic parts, wooden decorative elements and the dash panel

- Moisten a clean, lint-free cloth with water and clean the parts.
- Treat *plastic parts (inside and outside the vehicle) and the dashboard* with a special **solvent-free** plastic cleaning and care product approved by Volkswagen → ⚠.
- Treat *wooden trims* with a mild soap solution¹⁾.

Cleaning the seatbelts

The automatic belt will not be able to roll back properly if there is dirt on the belt and thus prevent the seat belt from working properly.

Seat belts must never be removed for cleaning purposes.

- Remove dirt with a soft brush → ⚠.
- Carefully pull the dirty seat belt right out and leave it out.
- Clean the seat belt with a *mild*¹⁾ soap solution.
- Allow the seat belt fabric to dry completely.
- Do not allow the seat belt to roll up until it has dried completely.

⚠ WARNING

Incorrect care and cleaning of vehicle parts can impair the safety features of the vehicle and thus cause serious injuries.

- Vehicle parts must be cleaned according to the manufacturer's instructions.
- Only use approved or recommended cleaning products.

⚠ WARNING

Cleaning agents that contain solvents cause the surface of the airbag modules to become porous. In case of an accident that triggers the airbag, loose plastic parts can cause serious injury.

- Never clean the dash panel or the airbag covers with cleansers that contain solvents.

⚠ WARNING

Check the condition of all seat belts regularly. Damaged belt bands or any other seat belt parts must be removed and replaced immediately by a Volkswagen Dealership. Damaged seat belts are extremely dangerous and can cause severe or fatal injuries.

- Never use chemical cleaning agents on the seat belts or their components. Additionally, seat belts may not come into contact with corrosive fluids, solvents or sharp objects. This can considerably weaken the bands.
- After cleaning, allow seat belts to dry completely before rolling them up. Otherwise the automatic belt retractors could become damaged and thus impair their function.
- Never let any foreign bodies or liquids enter the seat belt buckle slot. This could prevent the belt buckle and seat belt from working properly.

¹⁾ Smooth soap solution: two teaspoons of neutral soap in one litre of water.

- Never attempt to repair, modify or remove the seat belts yourself.
- Damaged seat belts must be replaced immediately with new seat belts approved by Volkswagen for your vehicle type. Seat belts subjected to stress and stretched during an accident must be replaced by a Volkswagen Dealership. Replacement may be necessary even if there is no apparent damage. The belt anchorage should also be checked.

! NOTICE

- Cleaning agents that contain solvents attack the material and can cause irreparable damages.
- Stains, dirt, and other deposits with corrosive components and solvents may cause irreparable damages to the material, even in case of short exposure periods.
- Stains, dirt and other deposits must be removed as quickly as possible and not allowed to dry in.
- To avoid damage, stubborn stains should be removed by a specialist cleaning company.

! NOTICE

- Do not use steam cleaners as the steam pushes the soiling into the fabric and sets it.
- High-pressure cleaners and coolant sprays can damage the upholstery.

! NOTICE

- Soft-bristle brushes should be used on carpets and mats only! Other surfaces could be damaged by brushes.
- When washing paste or fine detergent solutions are applied with a damp cloth or sponge, visible edges may appear on the upholstery once it has dried. These edges are usually difficult or even impossible to remove.

! NOTICE

- The NT - non-microfiber fabric cannot be drenched in any circumstances.
- Do not use leather care products, solvents, wax polish, shoe cream, stain removers or similar products on NT - non-microfiber fabric.
- Do not use brushes if cleaning with liquids. This could damage the surface of the material.

! NOTICE

- Never use solvents, wax polish, shoe cream, spot removers or similar products on leather.
- A stain cannot be removed if it has been left on the leather for a long time and has penetrated the surface.
- Spilt liquids should be cleaned immediately using an absorbent cloth as the leather surface and seams absorb liquids quickly.
- Protect the leather from excessive sun exposure to prevent fading.

! NOTICE

Never use solvents, wax polish, shoe cream, spot removers or similar products on vinyl. These may cause the material to become hard and brittle prematurely.

! NOTICE

Some car fresheners have substances in its chemical formula that may damage the structure, surface and paintwork of the vehicle's internal linings.

 Suitable care products are available from a Volkswagen Dealership.

 Volkswagen recommends cleaning stained upholstery in a qualified workshop.

 Slight colour changes of the natural leather covers due to use are normal. ◀

Accessories, modifications, repairs and part replacement

Accessories and spare parts

Volkswagen recommends that you seek advice from a Volkswagen Dealership before purchasing accessories, spare parts or service fluids. For example, if the vehicle is to be retrofitted with accessories or if parts have to be renewed. Volkswagen Dealerships can recommend accessories, parts and service fluids which are suitable for your requirements.

Volkswagen strongly recommends that you only use approved **Volkswagen Accessories** and **Volkswagen Genuine Parts**. These parts and ▶

accessories have been specially tested by Volkswagen for suitability, reliability and safety. Volkswagen Dealerships are also qualified to perform proper installation procedures.

Despite constant monitoring of the market, products **not approved by Volkswagen** cannot be evaluated by Volkswagen in terms of their credibility, safety and suitability for use in the vehicle. Volkswagen can therefore assume no responsibility for these parts, even if they have been approved by an official testing agency or are covered by an official approval certificate.

WARNING

Incorrectly performed repairs or modifications to your vehicle can impair the effectiveness of the airbags, cause operating failures, accidents and fatal injuries.

- Never secure or mount objects such as cup holders, telephone holders and GPS (global positioning system) on or next to the airbag covers or within the deployment zone of the airbag.
- Items which are either on or next to the airbag module covers or are in the deployment zone of the airbags can cause severe or even fatal injuries should the airbags be activated.

WARNING

Unsuitable spare parts and accessories as well as incorrectly carried out work, modifications and repairs can lead to damage to the vehicle, accidents and serious injuries.

- Volkswagen strongly recommends that you only use approved Volkswagen accessories and Volkswagen genuine parts. These parts and accessories have been specially tested by Volkswagen for suitability, reliability and safety.
- Repairs and modifications to your vehicle should only be carried out by a Volkswagen Dealership. Volkswagen Dealerships have the necessary tools, diagnostic equipment, repair information and qualified personnel.
- Never fit parts to your vehicle that are in any way different from the factory-fitted parts.
- Never secure or mount objects such as cup holders, telephone holders and GPS (global positioning system) on or next to the airbag covers or within the deployment zone of the airbag.

- Only use wheel/tyre combinations which have been approved by Volkswagen for your vehicle type. 

Repairs and technical modifications

Repairs and modifications must always be carried out according to Volkswagen specifications
→ 

Unauthorised modifications to the electronic components or software in the vehicle may cause faults. As the electronic components are linked together in networks, these faults may indirectly affect the working of other systems. This can seriously impair safety, lead to excessive wear of components, and also compromise the vehicle's operating function.

Volkswagen Dealerships cannot be held liable for any damage caused by technical modifications and/or work performed incorrectly.

The authorised Volkswagen repairer cannot be held liable for any damage caused by technical modifications and repairs performed incorrectly. Such damages are also not covered by the Volkswagen warranty.

Volkswagen recommends that all repairs and technical modifications be performed by an authorised Volkswagen Dealership with **Volkswagen Genuine Parts**.

WARNING

Incorrect repairs and modifications can cause functional problems and damage to the vehicle and impair the effectiveness of the driver assist systems. This could lead to accidents and severe injuries.

- Repairs and modifications to your vehicle should only be carried out by a Volkswagen Dealership. 

Repairs and limitations in the airbag system

Repairs and modifications must always be carried out according to Volkswagen specifications
→ 

Modifications and repairs to the front bumper, the doors, the front seats, the roof or the bodywork should be carried out by a Volkswagen Dealership. System components and airbag system sensors can be located on these vehicle components.

If you work on the airbag system or remove and install parts of the system when performing other repair work, parts of the airbag system may be damaged. The consequence may be that, in the event of an accident, the airbag inflates incorrectly or does not inflate at all.

Regulations must be observed to ensure that the effectiveness of the airbags is not reduced and that removed parts do not cause any injuries or environmental pollution. Volkswagen Dealerships are familiar with such requirements.

Any modifications to the vehicle's suspension could prevent the airbag system from working properly during a collision. For example, using tyre/ wheel combinations which have not been approved by Volkswagen, lowering the vehicle, making modifications to the suspension rate including work on the springs, struts and shock absorbers can affect the reaction of airbag sensors sending information to the electronic control unit. Some alterations to the suspension springs can, for instance, cause changes to the suspension and consequently affect the reaction of the sensors. This can lead to the airbag system being triggered in collision scenarios where it normally would not be triggered had no modifications been made to the suspension. Other modifications can affect the reaction measured by the sensors, preventing the airbag system from being triggered when it should have been.

WARNING



Incorrect repairs and modifications can cause functional problems and damage to the vehicle and impair the effectiveness of the airbag system. This could lead to accidents and severe injuries.

- Repairs and modifications to your vehicle should only be carried out by a Volkswagen Dealership.
- Airbag modules cannot be repaired. They must be replaced.
- Never use recycled airbag components or components that have been taken from end-of-life vehicles in your vehicle.

WARNING

Modifications to the vehicle's suspension, including the use of unsuitable tyre/wheel combinations not approved by Volkswagen may cause the airbag system to work differently and increase the risk of serious or fatal injuries in the event of an accident.

- Never install any components in the suspension system that do not have the same characteristics as the original factory-fitted components.
- Never use tyre/wheel combinations that have not been approved by Volkswagen.

 Airbag system parts must never be reused in case of vehicle or component scrapping. All applicable environment disposal standards must be followed, in addition to other safety standards in effect. Volkswagen Dealerships are familiar with such requirements. 

Retrofitting two-way radios

You will need an external aerial to use a two-way radio in the vehicle.

Any retrofit installation of electrical or electronic equipment in the vehicle will affect its vehicle type approval. Under certain circumstances, this can negate the type approval for the vehicle.

Volkswagen has approved the vehicle for use with two-way radios providing the following conditions are observed:

- Correct installation of external aerial.
- Maximum transmitting power of 10 watts.

An external aerial is needed to give the equipment its optimal range.

Should a two way radio need to be installed with a transmission power of more than 10 W, contact a specialized company. A qualified workshop is familiar with the technical options for retrofitting. Volkswagen recommends using a Volkswagen Dealership for this purpose.

Please observe legislation as well as the instructions and information given in the operating manuals for radio equipment. 

WARNING

If radio equipment is not secured or not properly secured in the vehicle, it could be flung through the interior during a sudden driving or braking manoeuvre, or in the event of an accident. This can cause injuries.

- While the vehicle is in motion, always secure two-way radios properly outside the airbag deployment zones or stow them away safely.

CAUTION

If two-way radios that are not connected to an external aerial are used, electromagnetic radiation in the vehicle could exceed limit values and thus be a health hazard for drivers and other vehicle occupants. This also applies to external aerials which have not been correctly installed.

- Two-way radios should only be used in the vehicle if an external aerial is properly connected.

Information stored in control units

Your vehicle is factory fitted with electronic control units which are responsible for engine and transmission management. The control units also monitor the function of the exhaust system and the airbags.

These electronic control units continuously evaluate data relevant to the vehicle while the vehicle is being driven. Only this data will be stored if there are any faults recorded or any deviations from the specified values. This is generally displayed by the indicator lamps on the instrument cluster.

Special units are required to read and evaluate data stored in the control units.

Under no circumstances do such control units record conversations held inside the vehicle.

Reprogramming control units

All data for the control of components is initially stored in the control units. Some convenience functions, such as lane change flash, single door unlocking and displays, can be reprogrammed using special workshop equipment. If the convenience functions are reprogrammed, the descriptions in your vehicle wallet will no longer correspond with the original functions.

Volkswagen recommends adding the reprogramming coverage to the digital warranty and maintenance at a Volkswagen Dealership.

Information about possible reprogramming can be obtained from Volkswagen Dealerships.

Reading the vehicle fault memory

A diagnosis interface for reading the fault memories is located in the vehicle interior → . Electronic control unit status and operating data is stored in the fault memory. Additional information on stored data can be obtained from your Volkswagen Dealership or qualified workshop.

The diagnostics connection is located on the driver's side footwell, near the fuse box.

The fault memory should only be read and reset by a Volkswagen Dealership.

After correcting faults, the respective data is deleted from the fault memory. Other memory contents are successfully updated.

WARNING

Improper use of the diagnostics connection may lead to operating faults, in addition to severe accidents and injuries.

- Never read the faulty memory through the diagnostics connection yourself.
- The diagnostics connection must only be read by a Volkswagen Dealership or qualified workshop.

Using a mobile telephone in the vehicle without a connection to the external aerial

During a telephone call and when in standby mode, mobile telephones transmit and receive radio waves, also known as high-frequency energy. Current scientific literature warns us that radio waves can be harmful to human beings if they exceed certain limits. Government agencies and international committees have introduced threshold values and guidelines to ensure that electromagnetic radiation produced by mobile telephones does not pose a hazard to health. However, there is no proven scientific evidence that demonstrates that cordless telephones are absolutely safe.

For this reason, some experts are calling for a precautionary use of mobile telephones through the application of measures which reduce the level of personal exposure to electromagnetic radiation.

If a mobile telephone which is not connected to the vehicle's external aerial is used inside the vehicle, the level of electromagnetic radiation could be higher than when the mobile telephone is connected to an integrated aerial or any other external aerial.

If the vehicle is fitted with a suitable hands-free unit which enables the use of innumerable additional functions of Bluetooth® compatible mobile telephones, this will comply with legal requirements in many countries which permit the use of a mobile telephone in a vehicle only if a hands-free unit is used.

Mobile telephones must be located in a suitable telephone holder or be stored securely in the vehicle. If a telephone holder is used it must be securely attached to the base plate. This is the only way to ensure that the mobile telephone is securely attached to the dashboard and always within reach of the driver.

If the mobile telephone is connected to a telephone aerial integrated in the vehicle or to an external telephone aerial, the electromagnetic radiation generated by the telephone that could affect the human body is reduced. Moreover, it improves the quality of the signal.

If a mobile telephone is used in the vehicle interior without this hands-free system, it is not safely secured in the vehicle and also not connected to the vehicle's external telephone aerial. Furthermore, the mobile telephone is not being charged in the telephone holder. It is also likely that the telephone connection will be disrupted and the signal strength will be poor.

A mobile telephone should only be used in the vehicle if it is connected to a hands-free unit. Volkswagen recommends the use of an external aerial when using a mobile telephone in the vehicle.

Bluetooth® is a registered trademark of Bluetooth® SIG, Inc.

WARNING

If a mobile phone is not secured or not properly secured in the vehicle, it could be flung through the interior during a sudden driving or braking manoeuvre, or in the event of an accident. This can cause injuries.

- Mobile telephones, other devices and telephone accessories such as telephone holders, notepads and GPS (global positioning system) must always be secured properly outside of the airbag deployment zones or be stowed in a safe place whilst the vehicle is in motion.

WARNING

If mobile telephones or two-way radios that are not connected to an external aerial are used, electromagnetic radiation in the vehicle could exceed limit values and thus be a health hazard for drivers and other vehicle occupants. This also applies to external aerials which have not been correctly installed.

- Maintain a minimum distance of 20 centimetres between the mobile phone's antenna and the heart pacemaker, since the former may interfere with the latter.
- Do not carry a mobile telephone in your breast pocket above a pacemaker.
- The mobile telephone must be switched off immediately if there is a suspicion of interference with a pacemaker or other medical devices.

Consumer information

Volkswagen warranty

Volkswagen Dealership Warranty

Volkswagen Dealerships provide a warranty against manufacturing defects for the vehicles sold by them.

Volkswagen Dealerships provide a warranty against manufacturing defects for new vehicles.

Please refer to your purchase agreement for more information on warranty terms and conditions.

For additional information, please contact your Volkswagen Dealership.

The warranty does not cover natural wearing, damages caused by abusive vehicle use, improper maintenance, or unauthorized modifications.

If your vehicle is not operating properly, please contact the nearest Volkswagen Dealership.

Body warranty

Volkswagen Dealerships grant vehicles they sell a warranty against puncture corrosion on the body.

In addition to the warranty terms for new Volkswagen vehicles, Volkswagen Dealerships also grant on the vehicles they sell – according to the purchase contract – a warranty against perforating body corrosion over a period of time limited to **6 years**.

In case such defects are eventually identified, they will be fully repaired by any Volkswagen Dealership free of charge.

The warranty is voided in the following cases:

- defects result from external influences or lack of proper vehicle maintenance; or
- any body defects are not repaired in a timely fashion, as per the Factory's instructions; or
- corrosion perforations result from noncompliance with the manufacturer's instructions regarding body repairs.

After conducting due body repair services, your Volkswagen Dealership will confirm due warranty coverage for corrosion perforations in the repaired area. <

General information

Volkswagen offers one of the largest and most efficient Dealership Network to assist your vehicle.

Volkswagen Dealerships are equipped with cutting-edge equipment and tools designed especially for your vehicle, in addition to highly-qualified technical personnel and a wide range of vehicle parts.

All Volkswagen Dealerships abide by high-end standards recommended by the Factory. These include Service instructions, which ensure all repair activities are carried out based on optimal quality standards and in a timely fashion, guaranteeing appropriate and safe vehicle conditions.

< Volkswagen Dealerships are clearly prepared to assist your vehicle. Make sure you don't miss out on all of these amenities. <

Additional service offers

Mandatory inspection services

Depending on local laws, the vehicle must be submitted to periodic mandatory inspections.

In several countries, vehicles must be periodically submitted to inspections conducted by competent authorities, duly evidencing its effective and safe traffic operation and/or exhaust system conditions.

Volkswagen Dealerships are aware of all mandatory inspections and duly qualified to perform such verification services, along with an inspection service. This will save you time and money.

They will indicate aspects that require special attention in order to prevent your vehicle from being submitted to new inspections due to faults. <

Volkswagen® Genuine Parts

Volkswagen® Genuine Parts are particularly designed for your vehicle and approved by Volkswagen, especially regarding safety measures. These parts accurately comply with Factory specifications regarding type, measurements, and materials. Volkswagen® Genuine Parts are the most suitable for your vehicle. Therefore, we recommend always using Volkswagen® Genuine Parts. Volkswagen does not guarantee the reliability, safety, and suitability of non-original parts.

The most essential Volkswagen® Genuine Parts are virtually always available in stock. If any specific part is not available in stock, it can usually be ordered and received in brief periods of time.

Volkswagen Dealerships offer a warranty for Volkswagen® Genuine Parts after assembly or purchase. Always keep your Volkswagen Dealership invoice for warranty purposes.

For additional information, please contact your Volkswagen Dealership.

Warranty claims regarding these parts can be filed **at any Volkswagen Dealership**.

Original Volkswagen accessories

We recommend using original Volkswagen accessories and other accessories approved by Volkswagen.

Please follow the recommendations below when equipping your vehicle with accessories:

Only use original Volkswagen accessories or other accessories duly approved by Volkswagen, whose reliability, safety, and suitability have been duly tested for the specific vehicle model. Volkswagen does not guarantee the reliability, safety, and suitability of non-original parts.

Volkswagen Dealerships offer a warranty for original accessories after assembly or purchase. Always keep your Volkswagen Dealership invoice for warranty purposes.

For additional information, please contact your Volkswagen Dealership.

In addition to providing accurate and updated information, the Volkswagen Accessories Service also offers optional equipment assembly services by qualified personnel.

In addition, Volkswagen Dealerships offer all appropriate products to maintain and care for your vehicle. ◀

Information stickers and plates

Safety certificates, stickers and plates containing important information on operating the vehicle are factory-fitted in the engine compartment and on certain parts such as the tank flap, front passenger sun visor, the driver door pillar or in the luggage compartment floor.

- Never remove or damage the safety certificates, stickers and plates. They must remain legible at all times.
- If vehicle parts bearing safety certificates, stickers or plates are removed from the vehicle, replacement safety certificates, stickers or plates with the same information must be applied properly to the new parts by Volkswagen Dealership or qualified workshop.

Safety certificate

A safety certificate on the door pillar of the driver door provides the information that all necessary safety standards and specifications of the transport safety authorities of the individual country have been met at the time of production. The month and year of production and the chassis number may also be listed.

High voltage warning stickers

There is a sticker near the engine compartment cover lock that provides a warning of the high voltage in the electrical system of the vehicle.

WARNING

Handling the vehicle incorrectly increases the risk of accident and injuries.

- Legal provisions must be followed.
- Consult the Owner's Manual.

NOTICE

Handling the vehicle incorrectly may cause damages to the vehicle.

- Legal provisions must be followed.
- Perform maintenance services as prescribed. ◀

Aerial and radio feed

A radio feed aerial is installed on the roof of vehicles with factory-fitted radio units.

 Interference of AM radio reception could occur if electric devices are used in the vicinity of the roof aerial (e.g. mobile phones).

Installing the radio

Follow the recommendations below when retrofitting a radio or replacing a factory-fitted radio:

- In some versions, existing vehicle connections were designed for original Volkswagen radios, as of the model year of 2005.
- Radio devices with different connections will have to use adapting cables, which are available at Volkswagen Dealerships.
- Radios **not** covered in the Volkswagen Original Accessories Programme may require additional adaptors if the signal feed is weak.
- Radios should be installed at a Volkswagen Dealership, whose personnel is qualified and trained on technical specifications of vehicles and if there are original radios and assembly parts required from the Volkswagen Accessories Programme, as well as the fact that all activities are conducted based on factory guidelines.
- The maximum power of original factory-fitted speakers is 20 W (RMS).
- Volkswagen recommends also using speakers, assembly sets, aerials and interference suppression kits of the Volkswagen Accessories Programme. These parts were designed especially for each vehicle type.

WARNING

Never cut the connection wire, leaving it exposed. This may cause fires.

NOTICE

- Different radio connections may destroy or affect important electrical components. Eventual interferences, such as the speed signal, may cause faults in the engine, ABS system, etc.
- Simply connecting the speed signal to a radio with automatic volume adjustment from different manufacturers may cause such faults.

Headphones

When using mobile phones or other devices, consult the respective owner's manual, applicable laws and standards regarding the use of headphones. For example, driving while using headphones is prohibited in Brazil.

WARNING

When using headphones while driving, exterior acoustic signals, such as police and fire department sirens and other vehicles' horns, may not be audible and may cause accidents.

Declarations of conformity



Fig. 205 Some approval identifications.

Approval identifications → Fig. 205:

- ① Argentina.
- ② Brazil.
- ③ Russia and countries that authorize and allow radio transmission systems as per EAC guidelines.
- ④ South Africa.

- ⑤ Europe and countries that authorize and allow radio transmission systems as per European guidelines.
- ⑥ Paraguay.
- ⑦ Zambia.
- ⑧ Mexico.

The individual manufacturer declares herewith that the following products comply with essential requirements of each country, among other relevant provisions and laws at the time of vehicle manufacturing:

Radiofrequency equipment

- Electronic immobilizer.
- Vehicle key with remote control.
- Keyless Access locking and starting system.
- Radios with Bluetooth connection.

FCC (Federal Communications Commission)

The following equipment is approved by the FCC under the identification number:

VW Play radio

- NT8-VWMIBREGIO

South Africa

The VW Play radio is approved by ICASA (Independent Communications Authority of South Africa) under identification number TA-2020/7390.

Argentina

The following equipment is approved by ENACOM (Entidade Nacional de Comunicações) under the identification number:

VW Play radio

- C-24447

Brazil

Devices activated by radiofrequency comply with all applicable approval and use standards, and their use in vehicles was authorized by the Brazilian National Telecommunications Agency (ANATEL).

Such approval must be used to obtain use licenses in other countries.

Ghana

The VW Play radio is approved by the NCA under identification number 7E5-7M-X0B-RDR.

Jamaica

The VW Play radio is approved by the SMA (Spectrum Management Authority).

Mexico

The VW Play radio is approved by the NOM (Norma Oficial Mexicana) under identification number IFT ID: RCPVIVW20-0478.

Paraguay

The VW Play radio is approved by CONATEL (Comisión Nacional de Telecomunicaciones) under identification number NR:2020-02-I-0111.

Zambia

The VW Play radio is approved by ZICTA (Autoridade de Tecnologia da Informação e Comunicação da Zâmbia) under identification number ZMB/ZICTA/TA/2020/10/51.



This equipment is not entitled to protection against prejudicial interference and do not cause interference in duly authorized systems. <

Technical data

Guidelines on the technical data

To check which engine a vehicle is equipped with, refer to the vehicle data sticker and vehicle license documents.

All data in the official vehicle documents take precedence over this data. All data in this manual are valid for the basic model. The figures may be different if additional equipment is fitted, for different models, for special vehicles and for other countries.

Engine

On the vehicle data sticker or in the vehicle documents it can be seen with which engine the vehicle is equipped.

Range

The values quoted here may differ if additional equipment is fitted, for different models or for special vehicles.

The values for the kerb weight in the following table apply for the road-ready vehicle with service fluids, including fuel tank carrying 90% of total capacity and tools and spare tyre, if applicable → ⚠. The indicated gear order weight is increased due to optional equipment and additional accessories installed, which proportionally reduces the maximum permitted load.

The load includes the following weights:

- Passengers.
- All luggage.
- Trailer towing support load.

Performance

Performance figures relate to the basic model. Data may vary according to the local fuel used, optional devices equipped in the vehicle, load, tyre pressure, temperature, altitude, vehicle route and driving habits. These figures were measured without equipment which may influence performance, such as mud flaps.

Gross combination weight

The listed admissible traction ratings are only applicable for altitudes of up to 1,000 m above sea level. The maximum weight of the car and trailer must be reduced by approximately 10% for every further 1,000 m in altitude.

⚠ WARNING

Ignoring or exceeding specific values and limits regarding weights, payloads, vehicle dimensions, and speed limit could result in severe accidents and injuries.

⚠ WARNING

Exceeding the permitted gross weight and axle weights may damage the vehicle and cause severe accidents and injuries.

- Actual axle loads must never exceed permitted axle loads.
- The payload and distribution of the load in the vehicle affect driving response and braking distance. Adjust your speed accordingly.
- Observing maximum weight and axle load limits is essential to ensure the safety of the driver, passengers and other road users.

⚠ WARNING

Accidents and severe injuries can occur if the maximum trailer weight is exceeded.

- Never exceed the specified maximum trailer weight.

ⓘ NOTICE

The payload should be distributed as evenly as possible in the vehicle. When transporting heavy objects in the luggage compartment, they should be placed either in front of or over the rear axle in order to minimise the effect on the vehicle's handling.

Information on fuel consumption

The figures quoted for fuel consumption and emissions do not refer to any one individual vehicle. Their purpose is to enable comparisons to be

made between various vehicle types. Fuel consumption does not depend exclusively on the efficiency of the vehicle, but also on the way it is driven and other non-technical factors.

Measuring fuel consumption

The vehicle consumption and emissions values were determined according to directive UE 70/220/EEC in the currently valid version and apply for the given vehicle kerb weight. The figures **do not** refer to any one individual vehicle. Two measuring cycles are carried out on a rolling road test bed to calculate fuel consumption. The test criteria are as follows:

Urban cycle The urban cycle starts with an engine cold start. Thereafter city driving at speeds between 0 and 50 km/h (0 and 31 mph) is simulated.

Extra-urban cycle In the extra-urban cycle the car undergoes frequent acceleration and braking in all gears, as in normal everyday driving. In this case the driving speed ranges from 0 to 120 km/h (0 to 75 mph).

Combined cycle The combined consumption is calculated with a weighting of around 37% for the urban cycle and 63% for the extra-urban cycle.

 Kerb weight may vary according to the respective version. This may slightly increase fuel consumption figures.

 In practical terms, fuel consumption figures may differ from those measured based on the UE 70/220/EEC guidelines.

Vehicle identification data

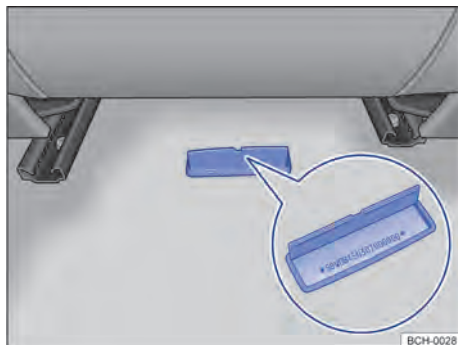

Fig. 206 In front of the rear passenger seat, on the right-hand side of the floor: vehicle identification number (running gear number).

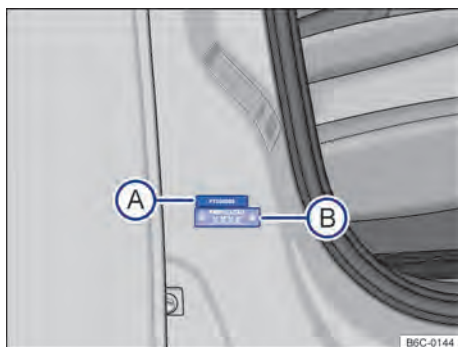

Fig. 207 In the lower area of the front right door pillar: vehicle partial identification number label (A) and manufacturing year plate (B).

Vehicle identification number (VIN - chassis number)

The vehicle identification number (VIN) engraving is located in front of the passenger seat, on the right-hand side of the floor → Fig. 206.

Partial vehicle identification number (VIS - partial chassis number)

The plates (VIS) are located on the lower area of the front right door pillar → Fig. 207 (A) and in the engine compartment on the driver side, in the suspension strut. These plates are destroyed when removed.

Additionally, the VIS number is also available in the windscreen, rear window, and side windows. ▶

Engine identification number

The engine identification number is located on the engine block. Open the bonnet to access the manufacturer identification sticker  → page 215.

In some regions, the engine identification number is included in the official vehicle document.

Manufacturer identification sticker

The manufacturer identification sticker is located in the front cross strut in the engine compartment. Open the bonnet to access the manufacturer identification sticker  → page 215.

Manufacturing year identification plate

The manufacturing year identification plate is located on the lower area of the front right door pillar → Fig. 207 . This plate is destroyed when removed.

NOTICE

In case it is necessary to replace stickers or re-engage vehicle components, contact a local Volkswagen Dealership.

NOTICE

The plastic layer applied over the vehicle identification number (chassis number) engraving is an anti-corrosive protection that prevents transferring the number into a paper sheet. Therefore, it must not be removed under any circumstances - risk of voiding warranty against perforation due to corrosion!

Information on the air conditioner

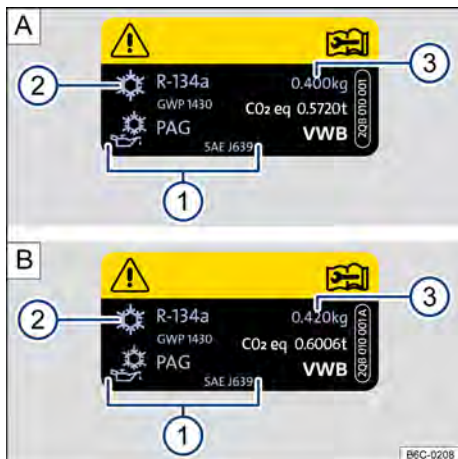











Fig. 208 : information on the air conditioner - 1.0-L engine. : information on the air conditioner - 1.0-L TSI engine, 1.4-L TSI engine, and 1.6-L engine.

Key for → Fig. 208:

-  Air conditioner lubrication oil specification.
-  Air conditioner coolant specification.
-  Air conditioner load level

Symbol and description:

-  Warning: air conditioning maintenance can only be carried out by qualified personnel.
-  Engine coolant type.
-  Lubricant type.
-  Check workshop information (only available for Volkswagen Dealerships).

WARNING

To ensure safe and risk-free operation, air conditioning system maintenance procedures may only be carried out by qualified personnel. 

Dimensions

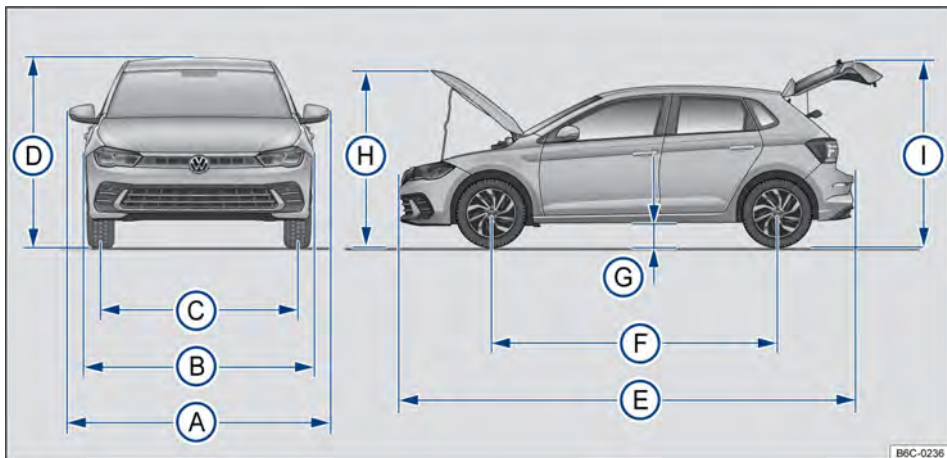

Fig. 209 Dimensions.

Table indications apply for the basic model with basic equipment.

Indicated values may vary due to wheel and tyre sizes, optional equipment, different model versions, or different accessory installations.

Key for→ Fig. 209:	Polo	Polo Track	Polo GTS
(A) Vehicle width (including exterior mirrors)	1,964 mm		1,976 mm
(B) Vehicle width (not including exterior mirrors)	1,751 mm		
(C) Front track ^{a)}	1,524 mm		1,508 mm
Rear track ^{a)}	1,506 mm		1,490 mm
(D) Vehicle level (ground to roof) ^{a)}	1,471 mm		1,481 mm
(E) Vehicle length	4,074 mm	4,079 mm	4,074 mm
(F) Clearance between axles	2,566 mm		
(G) Height of the free gap between the vehicle and the ground ^{a)}	153 mm	166 mm	175 mm
(H) Height with the bonnet open ^{a)}	1,781 mm	1,782 mm	1,791 mm
(I) Height with the tailgate open ^{a)}	2,014 mm	2,015 mm	2,026 mm
- Minimum vehicle rotation diameter	approximately 10.6 m		

^{a)} Data may vary according to wheel and tyre sizes.

NOTICE

- Drive carefully in parking lots with long kerbs or fixed posts. Objects higher than the ground level may damage the bumper and other vehicle parts when parking.

- Carefully drive through terrain entrances, ramps, kerbs, and other objects. Lowered vehicle parts, such as the bumper, spoiler and chassis, engine or exhaust parts may be damaged in these situations.

Capacities

Petrol engines

	1.0 Petrol TSI	1.4 Petrol TSI	1,6 Petrol 81 kW
Window washer fluid reservoir (→ page 217)	3.1 litres		
Fuel tank (→ page 191)	approximately 52 litres, of which approximately 7.5 litres reserve ^{a)}		
Engine oil capacity (→ page 220)	3.3 litres	4.0 litres	4.5 litres

^{a)} The reserve will be activated when the total tank level is reduced to approximately 7.5 litres of fuel.

TOTALFLEX Engines

	1.0 TOTALFLEX 57/62 kW (Polo Track)	1.0 TOTALFLEX 57/62 kW	1.0 TOTALFLEX 80/85 kW - TSI	1.4 TOTALFLEX 110/110 kW - TSI
Window washer fluid reservoir (→ page 217)	2.0 litres	3.1 litres		
Fuel tank (→ page 191)	approximately 52 litres, of which approximately 7.5 litres reserve ^{a)}			
Engine oil capacity (→ page 220)	3.3 litres		4.0 litres	

^{a)} The reserve will be activated when the total tank level is reduced to approximately 7.5 litres of fuel.

Petrol engines

1.0 petrol engine 74 kW - TSI

Power	74 kW (101 hp) at 5,000 rpm
Maximum torque	170 Nm (17.3 kgfm) at 1.750 rpm
EC	DHSE
Cylinders, Displacement	3 cylinders, 999 cm ³
Compression ratio	10,5:1
Spark plugs	04E.905.602.A ^{a)}
Unleaded petrol free from other metallic additives (such as manganese)	Super i.o. 95 Normal i.o. 91 ^{b)}
	<i>Valid only for Argentina</i> Grade 2 or Superior min. 91 ON
Gearbox type	6-speed Automatic (AQ 160)
Maximum speed ^{c)}	183 km/h
Acceleration 0 - 80 km/h ^{c)}	7.9 s
Acceleration 0 - 100 km/h ^{c)}	11.5 s
Kerb weight ^{d)}	1,147 kg
Gross axle weight permitted (GWP)	1,570 kg
Gross axle weight permitted in the front axle	860 kg
Gross axle weight permitted in the rear axle	760 kg
Roof load permitted	45 kg
Trailer with brake, gradients up to 8%	400 kg
Trailer without brake, gradients up to 8%	400 kg
Gross combination weight (CMT ^{e)})	1,970 kg
<i>Valid only for Argentina</i> Fuel consumption ^{f)} - Combined Euro 5 and Euro 4 legislation	6.7l/ 100 km
<i>Valid only for Argentina</i> CO ₂ emissions	154 g/km

- a) Volkswagen part number. Use only spark plugs recommended by Volkswagen in your vehicle, in order to prevent damages to the engine and ensure compliance with applicable emissions laws.
- b) With slight reduction in performance and increase in fuel consumption, with graded increase in engine noise until detonation regulation intervention.
- c) Figures are related to the basic model. Data may vary according to the local fuel used, optional devices equipped in the vehicle, load, tyre pressure, temperature, altitude, vehicle route and driving habits.
- d) Weight for basic model without optional equipment.
- e) CMT = vehicle gross combination weight + maximum trailer weight.
- f) For reasons of vehicle registration and taxation, the fuel consumption of some engines may differ from the following indications in other countries.



1.4 petrol engine 110 kW - TSI

Power	110 kW (150 hp) at 5,000 rpm
Maximum torque	250 Nm (25.5 kgfm) at 1,500 - 3,800 rpm
EC	DSJA
Cylinders, Displacement	4 cylinders, 1,395 cm ³
Compression ratio	10:1
Spark plugs	04E.905.602.A ^{a)}
Unleaded petrol free from other metallic additives (such as manganese)	Super i.o. 95 Normal i.o. 91 ^{b)}
	<i>Valid only for Argentina</i> Grade 2 or Superior min. 91 ON
Gearbox type	6-speed Automatic (AQ 250)
Maximum speed ^{c)}	204 km/h
Acceleration 0 - 80 km/h ^{c)}	5.8 s
Acceleration 0 - 100 km/h ^{c)}	8.5 s
Kerb weight ^{d)}	1,220 kg
Gross axle weight permitted (GWP)	1,640 kg
Gross axle weight permitted in the front axle	920 kg
Gross axle weight permitted in the rear axle	770 kg
Roof load permitted	45 kg
Trailer with brake, gradients up to 8%	400 kg
Trailer without brake, gradients up to 8%	400 kg
Gross combination weight (CMT ^{e)})	2,040 kg
<i>Valid only for Argentina</i> Fuel consumption ^{f)} - Combined Euro 5 and Euro 4 legislation	6.4 l/ 100 km
<i>Valid only for Argentina</i> CO ₂ emissions	146 g/km

- a) Volkswagen part number. Use only spark plugs recommended by Volkswagen in your vehicle, in order to prevent damages to the engine and ensure compliance with applicable emissions laws.
- b) With slight reduction in performance and increase in fuel consumption, with graded increase in engine noise until detonation regulation intervention.
- c) Figures are related to the basic model. Data may vary according to the local fuel used, optional devices equipped in the vehicle, load, tyre pressure, temperature, altitude, vehicle route and driving habits.
- d) Weight for basic model without optional equipment.
- e) CMT = vehicle gross combination weight + maximum trailer weight.
- f) For reasons of vehicle registration and taxation, the fuel consumption of some engines may differ from the following indications in other countries.

1,6 81 kW petrol engine

	Polo	PoloTrack
Power	81 kW (110 hp) at 5,750 rpm	
Maximum torque	155 Nm (15.8 kgfm) at 4.000 rpm	
EC	CWSA	
Cylinders, Displacement	4 cylinders, 1,598 cm ³	
Compression ratio	10,5:1	
Spark plugs	04C.905.606.A or 04C.905.616 ^{a)}	
Unleaded petrol free from other metallic additives (such as manganese)	Super i.o. 95 Normal i.o. 91 ^{b)}	
	<i>Valid only for Argentina</i> Grade 2 or Superior min. 91 ON	
Gearbox type	5-gear manual gearbox (MQ 200)	
Maximum speed ^{c)}	192 km/h	
Acceleration 0 - 80 km/h ^{c)}	6.3 s	
Acceleration 0 - 100 km/h ^{c)}	9.7 s	
Kerb weight ^{d)}	1,096 kg	1,080 kg
Gross axle weight permitted (GWP)	1,510 kg	
Gross axle weight permitted in the front axle	810 kg	
Gross axle weight permitted in the rear axle	760 kg	
Roof load permitted	45 kg	
Trailer with brake, gradients up to 8%	400 kg	
Trailer without brake, gradients up to 8%	400 kg	
Gross combination weight (CMT ^{e)})	1,910 kg	
<i>Valid only for Argentina</i> Fuel consumption ^{f)} - Combined Euro 5 and Euro 4 legislation	6.9 l/100 km	6.7 l/100 km
<i>Valid only for Argentina</i> CO ₂ emissions	161 g/km	154 g/km

a) Volkswagen part number. Use only spark plugs recommended by Volkswagen in your vehicle, in order to prevent damages to the engine and ensure compliance with applicable emissions laws.

b) With slight reduction in performance and increase in fuel consumption, with graded increase in engine noise until detonation regulation intervention.

c) Figures are related to the basic model. Data may vary according to the local fuel used, optional devices equipped in the vehicle, load, tyre pressure, temperature, altitude, vehicle route and driving habits.

d) Weight for basic model without optional equipment.

e) CMT = vehicle gross combination weight + maximum trailer weight.

f) For reasons of vehicle registration and taxation, the fuel consumption of some engines may differ from the following indications in other countries.



TOTALFLEX engines

1.0 57/62 kW TOTALFLEX engine

		Polo	Polo Track
Power	Petrol	57 kW (77 hp) at 6,450 rpm	
	Ethanol	62 kW (84 hp) at 6,450 rpm	
Maximum torque	Petrol	94 Nm (9.6 kgfm) at 4.000 rpm	
	Ethanol	101 Nm (10.3 kgfm) at 3.000 rpm	
EC		CSEB	
Cylinders, Displacement		3 cylinders, 999 cm ³	
Compression ratio		11,5:1	
Spark plugs		04C.905.607 ^{a)}	
Gearbox type		5-gear manual gearbox (MQ 200)	
Maximum speed ^{b)}	Petrol	170 km/h	166 km/h
	Ethanol	173 km/h	169 km/h
Acceleration 0 - 80 km/h ^{b)}	Petrol	9.3 s	9.3 s
	Ethanol	9.2 s	9.1 s
Acceleration 0 - 100 km/h ^{b)}	Petrol	13.8 s	13.8 s
	Ethanol	13.5 s	13.4 s
Kerb weight ^{c)}		1,069 kg	1,051 kg
Gross axle weight permitted (GWP)		1,465 kg	1,449 kg
Gross axle weight permitted in the front axle		780 kg	750 kg
Gross axle weight permitted in the rear axle		740 kg	735 kg
Roof load permitted		45 kg	
Trailer with brake, gradients up to 8%		200 kg	
Trailer without brake, gradients up to 8%		200 kg	
Gross combination weight (CMT ^{d)})		1,665 kg	1,649 kg
Idling speed ^{e)}		950 +/- 50 rpm	
CO emission at idle ^{e)}		< 0.2% (max)	

a) Volkswagen part number. Use only spark plugs recommended by Volkswagen in your vehicle, in order to prevent damages to the engine and ensure compliance with applicable emissions laws.

b) Figures are related to the basic model. Data may vary according to the local fuel used, optional devices equipped in the vehicle, load, tyre pressure, temperature, altitude, vehicle route and driving habits.

c) Weight for basic model without optional equipment.

d) CMT = vehicle gross combination weight + maximum trailer weight.

e) This vehicle complies with the Environment preservation program for motor vehicles (PROCONVE).

1,0 80/85 kW - TSI TOTALFLEX engine

Power	Petrol	80 kW (109 hp) at 5,000 rpm	
	Ethanol	85 kW (116 hp) at 5,000 rpm	
Maximum torque	Petrol	165 Nm (16.8 kgfm) at 1,750 - 4,250 rpm	
	Ethanol	165 Nm (16.8 kgfm) at 1,750 - 4,500 rpm	
EC		DHSD	
Cylinders, Displacement		3 cylinders, 999 cm ³	
Compression ratio		10,5:1	
Spark plugs		04E.905.602.F ^{a)}	
Gearbox type		5-speed manual (MQ 200) or 6-speed automatic (AQ 160)	
		Manual	Automatic
Maximum speed ^{b)}	Petrol	190 km/h	189 km/h
	Ethanol	195 km/h	192 km/h
Acceleration 0 - 80 km/h ^{b)}	Petrol	6.7 s	7.6 s
	Ethanol		7.1 s
Acceleration 0 - 100 km/h ^{b)}	Petrol	10.1 s	11.1 s
	Ethanol		10.5 s
Kerb weight ^{c)}		1,111 kg	1,154 kg
Gross axle weight permitted (GWP)		1,510 kg	1,570 kg
Gross axle weight permitted in the front axle		810 kg	860 kg
Gross axle weight permitted in the rear axle		760 kg	
Roof load permitted		45 kg	
Trailer with brake, gradients up to 8%		400 kg	
Trailer without brake, gradients up to 8%		400 kg	
Gross combination weight (CMT ^{d)})		1,910 kg	1,970 kg
Idling speed ^{e)}		920 +/- 50 rpm	980 +/- 50 rpm
CO emission at idle ^{e)}		< 0.2% (max)	

a) Volkswagen part number. Use only spark plugs recommended by Volkswagen in your vehicle, in order to prevent damages to the engine and ensure compliance with applicable emissions laws.

b) Figures are related to the basic model. Data may vary according to the local fuel used, optional devices equipped in the vehicle, load, tyre pressure, temperature, altitude, vehicle route and driving habits.

c) Weight for basic model without optional equipment.

d) CMT = vehicle gross combination weight + maximum trailer weight.

e) This vehicle complies with the Environment preservation program for motor vehicles (PROCONVE).



Engine 1.4 TOTALFLEX 110/110 kW - TSI

Power	Petrol	110 kW (150 hp) and 5,000 and 5,250 rpm
	Ethanol	110 kW (150 hp) and 4,500 and 5,000 rpm
Maximum torque	Petrol	250 Nm (25.5 kgfm) at 1,500 - 3,800 rpm
	Ethanol	250 Nm (25.5 kgfm) at 1,500 - 4,000 rpm
EC		DSJA
Cylinders, Displacement		4 cylinders, 1,395 cm ³
Compression ratio		10:1
Spark plugs		04E.905.602.A ^{a)}
Gearbox type		6-speed Automatic (AQ 160)
Maximum speed ^{b)}	Petrol	204 km/h
	Ethanol	206 km/h
Acceleration 0 - 80 km/h ^{b)}	Petrol	5.8 s
	Ethanol	5.7 s
Acceleration 0 - 100 km/h ^{b)}	Petrol	8.4 s
	Ethanol	8.3 s
Kerb weight ^{c)}		1.222 kg
Gross axle weight permitted (GWP)		1.640 kg
Gross axle weight permitted in the front axle		920 kg
Gross axle weight permitted in the rear axle		770 kg
Roof load permitted		45 kg
Trailer with brake, gradients up to 8%		400 kg
Trailer without brake, gradients up to 8%		400 kg
Gross combination weight (CMT ^{d)})		2,040 kg
Idling speed ^{e)}		750 +/- 50 rpm
CO emission at idle ^{e)}		< 0.2% (max)

a) Volkswagen part number. Use only spark plugs recommended by Volkswagen in your vehicle, in order to prevent damages to the engine and ensure compliance with applicable emissions laws.

b) Figures are related to the basic model. Data may vary according to the local fuel used, optional devices equipped in the vehicle, load, tyre pressure, temperature, altitude, vehicle route and driving habits.

c) Weight for basic model without optional equipment.

d) CMT = vehicle gross combination weight + maximum trailer weight.

e) This vehicle complies with the Environment preservation program for motor vehicles (PROCONVE).

Abbreviations

Abbreviation	Definition
A	Amp; electrical current measurement unit.
A/h	Ampere-hour.
A2DP	Audio transmission technology via Bluetooth® common in many manufacturers (Advanced Audio Distribution Profile).
ABS	Anti-lock brake system.
AM	Amplitude modulation (medium wave, MW).
AQ 160	6-speed automatic gearbox.
AQ 250	6-speed automatic gearbox TSI engine.
AUX	Auxiliary audio input.
AVRCP	Audio source remote control technology via Bluetooth® common in many manufacturers (Audio Video Remote Control Profile).
bar	Pressure unit.
BAS	Brake assist
BCM	Body Control Module.
CDM	Engine code.
cm ³	Cubic centimetres. Unit of displacement.
CO ₂	Carbon dioxide.
dB	Decibel, unit adopted to measure sound.
DIN	German Institute for Standardisation.
DRM	Digital Rights Management
DTMF	Dual Tone Multiple Frequency.
E-FLEX	Warm starting system.
EBV	Electronic brake variator.
ECE	Economic Commission for Europe-Regelung.
EDS	Electronic differential lock.
EON	Enhanced Other Network.
EPC	Engine management system (Electronic Power Control).
ESC	Electronic stability control.
ESS	Emergency brake lights (Emergency Stop Signal).
FM	Frequency modulation (ultra short wave, UKW)
GALA	Adjustment of the volume in relation to the vehicle's speed.
GRA	Cruise control system.
GSM	Global System for Mobil Communications.
HFP	Hands-Free-Profile.
hp	Horsepower, engine power.
IMEI	Serial number for the exclusive identification of the GSM (International Mobile Station Equipment Identity) end devices.
kg	Kilogram, mass unit of the International System of Units.



Abbreviation Definition

kPa	Kilopascal, standard pressure and tension unit of the International System of Units.
kW	Kilowatt, engine power.
l	Litre, capacity unit of the metric system.
LED	Light Emitting Diode.
m	Metre, length measurement unit of the International System of Units.
mm	Millimetre, length unit equal to one thousandth of a metre.
MP3	Audio file compression format.
MQ 200	5-speed manual transmission.
Nm	Newton metres, unit of engine torque.
° C	Celsius Degrees; temperature measurement unit.
PIN	Personal identification number.
psi	Pounds per Square Inch, tyre pressure information.
RDS	Radio Data System for additional services (Radio Data System - RDS).
rpm	Engine revolutions per minute.
s	Seconds, basic time measurement unit of the International System of Units.
SIM	Subscriber Identity Module.
SMS	Short Message Service
TCS	Traction control system.
TFT	Thin-film transistor display technology.
TSI [®]	Turbo charged with direct fuel injection.
TWI	Trade Wear Indicator.
UMTS	Mobile network standard (Universal Mobile Telecommunications System).
USB	Universal Serial Bus
V	Volts, electrical difference of potential measurement unit.
VBR	Variable bit rate.
VIN	Chassis number (Vehicle Identification Number).
VIS	Partial vehicle identification number with the last 8 digits of the running gear (Vehicle Indicator Section).
W	Watts, mechanical or electrical, thermal flow and energy flow of radiation measurement unit.
WMA	Audio file compression format.
XDS	Extension of the electronic differential lock.

Index

Numbers and Symbols

1,0 80/85 kW - TSI TOTALFLEX engine	278
1,6 81kW petrol engine	276
1.0 55/62 kW TOTALFLEX engine	277
1.4 petrol engine 110 kW - TSI	274, 275, 279

A

ABS	
see Brake assist systems	127
Accessories	260
Access the service deadline	26
Acoustic alarms	
light	79
Acoustic warning	
unfastened seat belt	35
Activated charcoal filter	193
Active Info Display	16, 17
information profiles	16, 17
Additional service offers	265
Adjust	
front seat	75
Adjusting	
correct sitting position	33
Headrest	77
steering wheel	73
Aerial	267
Air-conditioner	
AUTO (automatic mode)	94
Air-conditioning	
air recirculation mode	94
Airbag	
crash detection function	45
Airbag system	42
dash panel cleaning	257
description	44
differences among front passenger front air- bag systems	43
front airbag	46
function	44
indicator light	43
limitations	261
repairs	261
side airbags	48
switching off the passenger front airbag	47
switching off with the key activated switch	47
using child seats	47
vehicle conservation	257
wooden ornamental elements	257
Airbag System	
in case of airbag triggering	45

Air conditioner	
turn off	94
water underneath the vehicle	97
water vapour underneath the vehicle	97
window heating	94
Air conditioning	92, 93
air distribution	94
air recirculation mode	96
blower	94
controls	93
cooling mode	94
operating failure	96
operating instructions	96
temperature setting	94
tips	96
Air recirculation mode	96
air-conditioning	94
operation	96
switch off	96
Alarm system	68
interior monitoring system	68
risk of false alarm	69
Alertness detection system	
malfunction	25
Alterations	261, 266
AM	147
Ambient lighting	85
Analogue instrument cluster	15
Android Auto™	
connect	146, 173
disconnect	147
end connection	173
main menu	146
menu	173
particularities	147
specificities	173
Anti-lock brake system (ABS)	127
Anti-theft alarm system	68
description	68
Antifreeze	222
Anti theft coding	140
App-Connect	144
main menu	145
Apple CarPlay™	
disconnect	146
end connection	172
establish connection	145, 172
menu	145, 172
particularities	146
specificities	172
App store	171
basic functions	172
download	172

Areas with risk of explosion			
phone	158		
Ashtray	135		
removable	135		
Assemblies and insertions	261		
Assist systems			
anti-lock brake system (ABS)	127		
Automatic Post-Collision Braking System	128		
brake assist (BAS)	127		
driving mode selection	117		
Electronic Differential Lock (EDL)	127		
electronic stability control (ESC)	129		
Electronic Stability Control (ESC)	127		
park distance control	122		
rear view camera system	125		
Start-Stop system	108		
Traction control system (TCS)	129		
traction control (TCS)	127		
Tyre monitoring systems	231		
Tyre Pressure Loss Indicator	231		
uphill assist systems	115		
Assumptions			
rear view camera system	125		
Automatic belt retractor	41		
Automatic consumer deactivation	229		
Automatic driving light control	80		
Automatic gearbox	111		
blockage of the ignition key	107		
driving	113		
ignition lock	104		
Kick-down function	113		
Pulling away uphill	113		
shifting gear	111		
stopping on uphill slopes	113		
Automatic Post-Collision Braking System	128		
Automatic washing system	253		
AUX-IN			
see External audio sources	156		
AUX-IN multimedia port			
see External audio sources	156		
B			
Balance	166		
BAS			
see Brake assist systems	127		
Battery			
check vehicle battery	226		
replacing the battery in the vehicle key	61		
Battery electrolyte	228		
Belt height adjuster	41		
Belt tensioner			
disposal	42		
service and disposal	42		
Bluetooth			
audio function	170		
connect	170		
phone function	170		
profiles	158		
settings	165		
Bluetooth Audio			
see External audio sources	156		
Body warranty	265		
Bonnet			
display indication	216		
warning lamp	216		
Boot lid	69		
check boot lid	69		
emergency opening or closing	71		
opening	70		
unlocking	70		
Brake			
brake support system	127		
emergency brake indicator	58		
handbrake	121		
Brake assist (BAS)	127		
Brake fluid	224		
specification	225		
Brake light bulb	202		
Brake pad			
run-in	100		
Brake pad run-in			
also see brakes	100		
Brakes			
brake fluid	224, 225		
brake pad run-in	100		
brake pads	100		
brake servo	101		
changing brake fluid	225		
fault	103		
Brake servo	101, 127		
Brake support system	127		
Brake support systems	127		
ABS	127		
BAS	127		
EDS	127		
ESC	127		
TCS	127		
XDS	127		
Brake system	127		
check brakes	103		
troubleshooting	103		
Bulb failure			
see Exterior lighting	197		
Bulb replacement			
removing and installing the headlights	199		
Buttons	141, 142		

C

Call lists	163	lifting the vehicle with the jack	247
Call voice mailbox	162	preparations for changing a wheel	244
Capacities		preparations for travel	31
engine oil	221, 273	safe driving	31
fuel tank	191, 273	seat belts	38
washer fluid reservoir	273	travels abroad	31
windscreen washer reservoir	217	Checks when fueling	31
Caring for the vehicle		Check the engine oil	220
cleaning the window wiper blades	196	Childproof lock	57
replacing window wiper blades	196	Child seat	
window aerial	267	airbag sticker	51
Car phone	262	securing systems	50
Carrier		securing with the seat belt	56
see Roof carrier	182	securing with Top Tether	55
Catalytic converter	192	switching off front passenger front airbag	47
operating failure	194	weight classes	50
Central locking	63	Child seats	49
central locking button	65	child seat types	49
description	64	standard	50
Keyless Access	62	transporting children in the vehicle	51
locking or unlocking from inside	65	Cigarette lighter	135
single door unlocking	64	Cleaning	
Central locking system		see Vehicle conservation	252
anti-theft alarm system	68	Clean the display	140
Centre arm rest	78	Clock	15, 25
Changing a wheel	244	Clock setting	
lifting the vehicle	247	digital clock	15
preparation actions	244	Close	
wheel bolts	246	doors	63
Changing bulbs		tank flap	191
checklist	198	windows	71
in the bodywork	202	Clothing hook	134
in the headlights	200	Coming Home function	83
number plate light	203	Connection	
preparation actions	198	USB	155
rear lights	202	without wires	154
Changing gears		with wires	154
gear change indication	98	Conservation	
manual gearbox	110	see Vehicle conservation	252
selecting gears (manual gearbox)	110	Conservation of aluminium parts	255
Changing the wheel		Conservation of the chrome parts	255
after changing a wheel	249	Consumables	216
changing the wheel	248	Consumer information	265
Chassis number	270	Control	
Checkboxes	142	RADIO	147
Checking and refuelling	213	Control light	
Checklist		fuel level	18
before working in the engine compartment	214	fuelling	18
changing bulbs	198	Control list	
checks when fuelling	31	before using the unit for the first time	137
check the engine oil level	220	rear view camera system	125
fill engine oil	220	Controls	141
in an emergency	58	additional displays	144
in case of faults	58	basic control information	141
		checkboxes	142
		display keypad	143

enter	143	Defrosting	
entry mask	143	windows	94
function surfaces	142	Device overview	141, 167
Phone	157	Diagnostics connector	263
PHONE	160	Differential lock	
scroll	143	see Electronic Differential Lock (EDL)	127
scroll bar	143	Digital clock	25
search lists	143	digital instrument cluster	
touchscreen	142	see Active Info Display	17
Control units	263	Digital instrument cluster	
reprogramming	263	see Active Info Display	16
Convenience closing		Dimensions	272
electric windows	71	Dipped beam bulb	200
Convenience functions		Display	16, 17, 20, 21, 140, 141
reprogramming	263	clean	140
Convenience opening		controls	142
electric windows	71	instrument cluster	20, 21
Convenience overview	137	Display indicators	
Coolant		cruise control system (GRA)	118
check engine coolant	222	doors, bonnet and boot lid open	20, 21
Copyright		time	25
information	166	Display keypad	143
Copyrights	150, 169	Disposal	
Crash detection function		belt tensioner	42
airbag	45	Doors	63
Cruise control system	118	childproof lock	57
Cruise control system (GRA)		emergency closing or opening	66
display indicators	118	Driver alert system	24
operation	119	function	24
crystal waxing the paintwork	253	operation	24
Cup holder	134	turn off	24
front centre console	135	turn on	24
Cup holders		Driver door	
beverage bottles	134	overview	9
D		Driving	
Dashboard		data records	263
airbag system	42	driving economically	98
Dash panel		driving through water on roads	102
airbag system	257	fuel gauge	18
cleaning	257	fuel level too low	18
Dash panel insert		parking on downhill inclines	120
indicators	27	parking on uphill inclines	120
menu structure	27	preparations for travel	31
operation by way of the multifunction steering wheel	28	pulling away uphill	113
Dash panel insert operation	27	stopping on uphill slopes	113
operation by way of the windshield wiper lever	27	through salt water	103
Data recording	263	travels abroad	31
Data recording while driving	263	with automatic gearbox	113
Date setting	165	with environmental awareness	98
daytime driving light	80	Driving economically	98
Daytime running light	79	Driving guidelines	97
Declarations of conformity	267	Driving instructions	
		temporary spare wheel	239
		Driving in the winter	
		mirror	88
		winter tyres	242

Driving mode selection	117	Engine	
default behaviours of driving modes and vehicle systems	117	irregular engine operation	193
Driving safety	31	noises	106
Driving saving fuel	98	running-in	103
Driving through salt water in roads	103	Engine and ignition	104
Driving through water on roads	102	automatic ignition turn off	105
Driving with environmental awareness	98	emergency shut down	108
During a phone call	161	emergency start function	107
Dust filter	96	ignition cylinder	104
		immobilizer	107
		non-authorized vehicle key	104
		starting the engine with Keyless Access	104
		start the engine	105
		stopping the engine	106
		unauthorized vehicle key	107
E		Engine compartment	213
E-FLEX	226	cleaning	255
EBV		engine coolant	222
see Braking support systems	127	engine oil	218
Economical driving style	98	plenum chamber	255
EDL		preparation activities	214
see Brake support systems	127	vehicle battery	226
Electrical consumer	136, 186	Engine compartment cover	
Electric consumers	136	closing	215
Electricity-consuming equipment	59	opening	215
Electric windows	71	Engine control unit	192
buttons	71	Engine coolant	222
close	71	check engine coolant level	223
convenience closing	71	refilling	223
convenience opening	71	refilling opening	223
open	71	specifications	222
operational failure	72	temperature indicator	19
roll-back function	72	warning light	19
Electronic brake variator (EBV)	127	engine data	279
Electronic Differential Lock (EDL)	127	Engine data	274, 275, 276, 277, 278
Electronic engine power control - EPC	192	Engine identification number	
Electronic immobilizer	107	establish	271
Electronic Stability Control (ESC)	127	Engine management	
Electronic Stability Control(ESC)	129	indicator lamp	107
Emergency brake indicator	58	troubleshooting	107
Emergency brake lights	58	Engine oil	218
Emergency breakaway cable	185	changing	219
Emergency closing		check the engine oil	220
front passenger door	67	complete	220
rear doors	67	consumption	219
Emergency closing or opening		engine oil filler	220
driver door	66	oil dipstick	220
emergency unlocking the selector lever	114	specification	218
Emergency opening or closing		Engine speed	18
boot lid	71	Entry mask	
Emergency shut down	108	see Controls	143
Emergency start function	107	Environmental impact note	
Emergency unlocking the selector lever	114	fuel	191
Engaging the gear		EPC - Electronic engine power control	192
automatic gearbox	111		

ESC			
enable and disable	129	fuel	
see Braking Support Systems	129	Ethanol	190
ESS - Emergency Stop Signal	58	Fuel	189
Ethanol	190	environmental impact note	191
fuel gauge	18	information on fuel consumption	269
Exhaust gas emission control system	192	petrol	190
Exterior		problems	193
door handles	7	Fuel consumption	
Exterior lighting	197	driving economically	98
Exterior mirrors	90	how to measure?	269
fold	90	information	269
memory for reverse gear	90	what increases consumption?	194
operation failure	91	Fuel gauge	18
towing a trailer	185	control light	18
Exterior temperature indicator	20, 21	petrol or ethanol	18
External aerial	262	Fuel handling safety guidelines	189
External audio source		Fuelling	
adjust playback volume	166	checks when fuelling	31
External audio sources		control light	18
AUX-IN multimedia port	156	ethanol	191
Bluetooth audio	156	fuel gauge	18
USB connection	155	petrol	191
External data carrier		with ethanol	191
USB connection	155	with petrol	191
External jump starting		fuelling and fuel types	189
check Jump starting	209	Fuel quality	194
external mirrors		Function buttons	
vehicle conservation	255	MEDIA main menu	152
		PHONE main menu	160
		RADIO main menu	147
		Function surfaces	142
		controls	142
		Fuses	204
		changing	208, 209
		colour coding	209
		dash panel	205
		detecting a blown fuse	209
		engine compartment	207
		fuse box in the dashboard	205
		fuse box in the engine compartment	207
		fuse box in the engine compartment on the battery	208
		preparations for changing	209
		versions	209
		G	
		Gear change indicator	98
		General information	265
		Glasses compartment	133
		Glove compartment	
		light	86
		see Glove compartment	132
		GRA	118
		Grounding point	210
		Guidelines for the conservation of the vehicle	252
F			
Fader	166		
Fault memory	263		
Faults			
protect the vehicle	58		
Favourites (speed dial buttons)	164		
Fire extinguisher	59		
First service	251		
Fixation with i-Size	53		
Fixation with ISOFIX			
child chair	53		
Fixation with LATCH	53		
FM	147		
Frequency range			
AM	147		
change	142, 147		
FM	147		
select	142, 147		
Front airbag			
check airbag system	46		
Front passenger airbag			
check airbag system	42		
Front passenger side glove compartment light	86		
Front seat	74		

Guidelines on the technical data	269	shifting gear	114
		Start-Stop system	108
		turn signals	85
		tyre monitoring system	232
H		Indicator lamps	
Handbrake	121	overview	13
Head light lever	79	Indicator light	
Headlights		airbag system	43
international trips	85	Indicators of the display	
washers	87	Warning and information texts	23
Headphones	267	Indicators on the dash panel insert display	27
Headrest	77	Information on fuel consumption	269
Head restraints	77	Information on the air conditioner	271
Heating	92, 93	Information on the warm starting system	226
Heating and air conditioning	92	Information profiles	16, 17
High pressure washing machine	253	Information stored in control units	263
Hollow cavities	255	Initial settings	165
Hooks to hang bags on	181	Installing the radio	267
Horn	10	Instructions for use	139
Hour setting	25	Instrument cluster	10, 14
Hub cap		display	15, 16, 17, 20, 21
wheel bolt cap	244	indicator lamps	13
Hub caps	243	instruments	15, 17
		Instruments	16
		service interval display	26
		symbols	13
		warning lamps	13
		Instruments	15, 16, 17
I		Interior light	85
Identification number	270	Interior lighting	85
Identification sticker	270	Interior mirror	89
Ignition	104	Interior monitoring system	68
check engine and ignition	104	Intermittent convenience signals	79
non-authorized vehicle key	104	International trips	
Ignition lock		headlights	85
blockage	107	Interval recommendation	24
lock	104	function	24
removing the key from the ignition	107	operation	24
Ignition turned off		turn off	24
post-operation (Timeout)	141	turn on	24
Immobiliser		iPad	155
malfunction	108	iPhone	155
In an emergency	58	iPod	155
checklist	58	ISOFIX	53
faults	58		
making you and your vehicle safe	58	J	
warning lamps	58	Jump starting	209
In case of emergency		grounding point	210
warning triangle	59	jump starting point (grounding point)	210
Indicator and warning lamp		K	
manual gearbox	110	Key	
Indicator lamp		see vehicle key	60
ABS	129		
braking support systems	129		
central locking	64		
engine management	107		
ESC	129		
malfunctioning bulb	85		
on the driver door	64		
seat belt	35		

Key activated switch			
switching off the passenger front airbag	47		
Keyless Access	62		
starter button	104		
Unlock or lock with Keyless Access	62		
Keyless Access Locking and starting system			
see Keyless Access	62		
Keyless locking and starting system Keyless Access	62		
Keypad			
see Controls	143		
Kick-down function	113		
L			
Lambda probe	193		
Lamp			
Coming Home	83		
interior lights	85		
Leaving Home	83		
reading lights	85		
LATCH			
child chair	53		
Leaving Home function	83		
Lifting the vehicle			
checklist	247		
jack	247		
with the jack	247		
Light			
acoustic alarms	79		
daytime running light	79		
functions	80		
headlight lever	79		
instruments and switches lighting	85		
light's switch	79		
side light	79, 80		
switch off	79		
switch on	79		
turn signal lever	79		
lighting			
Turn signals	79		
Lighting			
daytime driving light	80		
Driving light	79		
troubleshooting	85		
Lights	79		
AUTO	80		
Load capacity index	241		
Loading			
driving with the rear lid open	102		
luggage compartment	178		
roof carrier	183		
stowing items of luggage	178		
towing	186		
Locking			
with Keyless Access	62		
Locking button			
automatic gearbox	111		
Locking the front passenger door and rear doors in case of emergency	67		
LOW BATTERY	140		
Luggage compartment	178		
cover	179		
luggage compartment light	85		
luggage net	181		
Variable luggage compartment floor	180		
Luggage compartment cover	179		
Luggage compartment floor	180		
Luggage net	181		
Luggage compartment	181		
M			
Main beam bulb	200		
Main beam on/off	81		
Main indicator	17		
Main menu			
Android Auto™	146		
App-Connect	145		
MEDIA	152		
PHONE	160		
RADIO	147		
Maintenance	249		
malfunction			
park distance control	122		
Malfunction			
alertness detection system	25		
immobiliser	108		
tyre monitoring system	232		
Mandatory inspection services	265		
Manoeuvre braking	123		
Manual gearbox	110		
indicator and warning lamp	110		
see also Changing gear	110		
see also Shift gears	110		
trouble shooting	110		
Mats	97		
Mechanical windows			
close	71		
open	71		
Media	169		
copyrights	169		
file and database requirements	169		
media controls	169		
media operation	170		
settings	174		
MEDIA			
audio data structure	152		
audio file CD	151		
AUX-IN multimedia port	156		
bitrate	151		
Bluetooth audio	156		

change media source	153
Change track	153
copyrights	150
displays	152
external data carrier to USB	155
forward and back	153
function buttons	152, 153
iPod, iPad, iPhone	155
limitations	151
main menu	152
media mode	150
media source selection menu	153
Mix function	153
MP3 files	151
playback mode	153
playback sequence	152
playlists	151
prerequisites	151
Repeat function	153
SD card	154
select data storage unit	153
select track	154
settings	154
WMA files	151
Menu	
Apple CarPlay™	145
Mileage recorder	15, 17
Mirror	
areas with no visibility	88
blind spot	88
Mirrors	88, 89
exterior	90
folding	91
interior mirror	89
right-hand exterior mirror operation	90
Mix function	153
Mobile phone	
use without external aerial	263
Modifications	261
Multi Collision Brake	
see Automatic Post-Collision Braking System	128
Multifunction display	22
Multifunction steering wheel	10, 28
Multimedia playback	
SD card	155
Multimedia port	155
N	
New engine	103
Noises	
brake assist system	128, 129
engine	106
tyres	243
NT - non microfiber fabric	257
Number of seats	32
O	
Octane number	190
Odometer	16
Oil	
check engine oil	218
Oil dipstick	220
Old tyres	234
Open	
doors	63
tank flap	191
windows	71
Opening	
boot lid	70
Open radio stations list	142
Operating failure	
air conditioning	96
catalytic converter	194
radio feed	267
rain sensor	88
Operation	
park distance control	123
turn on and off	141
Operational failure	
electric windows	72
Operation failure	
electric exterior mirrors	91
Original Volkswagen accessories	266
Other applicable documents	137
Overall guidelines	31
Overseas	
extended permanence	103
vehicle sales	103
Overview	141
centre console	11
driver door	9
driver's side	10
front passenger side	12
front view	6
indicator lamps	13
instruments	15, 16, 17
menu structure	27
rear view	8
roof headliner	12
side view	7
turn signal and main beam lever	79
warning lamps	13
Overview of the vehicle	
front view	6
rear view	8
side view	7
P	
Park distance control	122
operation	123

displays and symbols	149	Removing wax residues	255
function buttons	147, 149	Renew bulbs	
main menu	147	see Exterior lighting	197
pre-tuning buttons	149	Repairs	260, 261
radio data system RDS	148	airbag system	261
radio text (RDS)	148	plates	266
SCAN	150	stickers	266
settings	150	Repeat	153
station buttons	148	Repeat function	153
Radio buttons	142	Replacement key	
Radio controls and display	28	see vehicle key	60
Radio feed		Representation on the display	
aerial	267	Park Distance Control	124
operating failure	267	Reprogramming control units	263
Radios	137	Retrofitting	
Radio stations		car phone	262
pre-tuning	149	two-way radio	262
Radio text (RDS)		Rev counter	17
see RDS	148	Right-hand exterior mirror operation	90
Rain sensor	87	Right-hand turn signal bulb	200
operating failure	88	Rims	
RDS	148	cleaning	255
radio text	148	Roll-back function	
regional RDS	148	electric windows	72
station names	148	Roof carrier	182
Reading light	85	fastening base supports	182
Rear lid		Usage guidelines	184
driving with the rear lid open	102	Rotary knobs	141
Rear lights		Rubber seals	255
changing bulbs	202	Run-in	
Rear seat	76	tyres	235
Rear seat backrest		Running-in	
fold backwards	76	engine	103
fold forward	76	first kilometres	103
Rear seats	75	S	
Rear View		Safety equipment	45
see Rear view camera system	125	Safety recommendations	138
Rear view camera system	125	SCAN	
assumptions	126	radio	150
control list	125	RADIO	150
Enabling and disabling	125	Screen	
operational guidelines	126	settings	174
parking	126	Scroll	143
Representation on the display	125	Scroll bar	143
settings	126	SD card	
Rear window defrost function	95	compatibility and technical data	151
Rear window wiper blade		eject or insert	154
cleaning	196	prepare to remove	154
replacing	196	prerequisites	151
Reduction of exhaust gases		supported SD files	151
problems	193	unreadable	154
Removable ashtray	135	SD card slot	154
Removing and installing the headlights	199	Search lists	143
Removing ice	255		
Removing snow	255		

Seat	76	system	165
Seat belt		user profile	165, 177
automatic belt retractor	41	valet mode	176
seat belt status indicator	35	volumes	166
warning lamp	35	Shifting gear	
Seat belt roll-back function	41	automatic gearbox	111
Seat belt routing	39	emergency unlocking the selector lever	114
Seat belts	34	shifting gears (automatic gearbox)	111
belt height adjuster	41	with the Tiptronic	112
belt routing	39	Shifting gears	
checklist	38	warning and indicator lamps	114
cleaning	257	Shift paddle	
fastening	39	Tiptronic	112
not fastened	37	Side airbags	
roll-back function	41	see Airbag system	48
seat belt tensioner	41	Side light	79, 80
twisted seat belts	38	Side light bulb	200, 202
unfastening	39	Single door unlocking	64
using	38	Sitting	
Seat belts protect	37	adjusting the headrest	77
Seat belt tensioner	41	adjusting the steering wheel position	73
Seat covers	257	correct sitting position	33
cleaning NT - non microfiber fabric	257	Installing the headrest	77
cleaning the fabric cover	257	number of seats	32
cleaning the padding	257	rear seat backrest	76
conserving and cleaning the natural leather	257	Removing the headrest	77
seat cover handling	257	Sitting position	
vinyl	257	incorrect position	33
Seat functions	78	Sliding headliner	92
Seats	32, 74	Socket	136
front seat	75	12 Volts	136
Selection of driving mode		Softkeys	
characteristics of driving modes	117	see Function surfaces	142
Selection of the driving mode		Sounds	
manoeuvre	117	warning lamps and indicator lamps	13
operation	117	Sound settings	166
Selector button	142	Spare fuel canister	189
Selector lever lock		Spare parts	260
automatic gearbox	111	Spare wheel	239
Select (phone number)	162	remove	239
Service	249	Special precaution areas	158
Service fluids	216	Specificities	
Service interval display	26	AUX playback	156
Service menu	25	displays	144
Service position		engine jolting	193
Windscreen wipers	196	folding mirrors	91
Service scopes	251	irregular engine operation	193
Set		parking	121, 272
hour	25	radio feed	267
Settings	165	remove the vehicle key	104
Bluetooth	165	towing a trailer	187
factory settings	165	Speed alarm	23
media	154	Speed index	242
PHONE	164	Sport function	30
radio	150	Start-Stop system	108
		indicator lamp	108

Start-Stop System	108	System	
Start button		ABS	127
emergency shut down	108	anti-lock brake system (ABS)	127
emergency start function	107	settings	174
Starter button	104	Systems	
Starting the engine with jump leads		automatic driving light control	80
how to	211	BAS	127
jump leads	211	brake assist (BAS)	127
Station		cruise control system	118
SCAN	150	EBV	127
scanning for stations	150	EDL	127
Station buttons	148	electronic brake variator (EBV)	127
Station names		Electronic Differential Lock (EDL)	127
see RDS	148	GRA	118
Steering		TCS	127
indicator lamp	116	traction control (TCS)	127
warning light	116	Uphill assist system	115
Steering assistance	116	XDS	127
Steering wheel			
adjusting	73	T	
unilateral traction	238	Tachometer (Rev counter)	18
vibration	238	Tank flap	
Stickers	266	check tank flap	191
Stopped in traffic		ethanol	191
protect the vehicle	58	petrol	191
Storage compartment		TCS	
glasses compartment	133	enable and disable	129
roof console	133	see brake assist systems	127
Stowage area		see Braking Support Systems	129
front centre console	131	Technical data	269
front passenger side	132	1,0 80/85 kW - TSI TOTALFLEX engine	278
glove compartment	132	1,6 81kW petrol engine	276
Glove compartment light	86	1.0 55/62 kW TOTALFLEX engine	277
in the lower part of the centre console	131	1.4 petrol engine 110 kW - TSI	274, 275
vehicle wallet	132	capacities	191, 217, 221, 273
Stowage compartment	130	dimensions	272
front centre armrest	133	engine oil specification	218
Stowage compartments		identification sticker	270
other stowage compartments	134	petrol engine	274
Stowing items of luggage	178	roof load	183
Sun visor	92	TOTALFLEX engines	277
Support load		type plate	270
loading the trailer	186	tyre pressure	236
Support systems		Vehicle data sticker	270
cruise control system	118	Technical Data	
driver alert system	24	1.4 petrol engine 110 kW - TSI	279
electronic brake variator (EBV)	127	Technical modifications	261
GRA	118	plates	266
interval recommendation	24	stickers	266
Symbol entry mask	143	Temperature display	
Symbols		engine coolant	19
see Indicator lamps	13	Temperature indicator	
see Warning lamps	13	exterior temperature	20, 21
Synchronize vehicle key	61	Temporary spare wheel	
		driving instructions	239

Temporary spare wheel of different size from the regular wheels	245	towing	184
Text entry		towing a trailer	187
see Controls	143	Transporting children in the vehicle	49, 51
Thawing the door lock cylinder	255	Travel data	22
Thawing the locks	255	Travel data indicator	22
Things to note		Travels abroad	
towing	212	checklist	31
tow starting	212	Tread depth	237
Tightening torque		Tread depth and wear indicators	237
wheel bolts	246	Treadwear	241
Timeout	141	Troubleshooting	67, 71
Time setting	165	12 V vehicle battery warning lamp	230
TIN	240	airbag deployment	68
Tiptronic	112	airbags system	44
Toolkit		alternator warning lamp	230
check vehicle toolkit	194	Auto Lock	67
TOTALFLEX engines	277	braking support systems	129
Towing	184, 212	check engine oil level	221
a trailer	187	cruise control system (GRA)	119
connecting	185	driving mode selection	118
emergency breakaway cable	185	dual clutch gearbox	114
engaging	185	Trouble shooting	
exterior mirrors	185	engine management	107
headlight adjustment	187	Troubleshooting	
loading	186	engine oil level sensor	221
rear lights	185, 186	engine oil pressure	221
retrofitting a towing bracket	188	faulty bulb	204
support load	186	front passenger front airbag disabled	44
technical requirements	185	front passenger front airbag enabled	44
things to note	212	ignition lock	107
towing a trailer	187	immobiliser	107
trailer load	186	indicator lamp of the driver door	67
Towing a trailer		Keyless Access	63, 67
check towing	184	Trouble shooting	
Towing bracket		manual gearbox	110
retrofitting	188	Park Distance Control	124
Tow starting	212	Troubleshooting	
things to note	212	re-establishing the one touch closing and opening operation of the windows	72
Tow starting and towing		Start-Stop system	109
towing	212	start button	107
Track list	154	steering	116
Traction	241	turn signals	67
Traction control system (TCS)	129	Turn off	
Traction control (TCS)	127	radio	141
Trailer load		Turn on	141
loading the trailer	186	Turn signal and main beam lever	79
Transporting	178	Turn signal light bulb	202
driving instructions	101	Turn signals on/off	79
driving with the rear lid open	102	Two-way radio	262
Hooks to hang bags on	181	Type plate	270
loading the trailer	186	Tyre control indicator	
luggage net	181	change the tyres	235
roof carrier	182, 183	Tyre damage	238
stowing items of luggage	178	Tyre load capacity	242

Tyre monitoring system	231	connecting	228
indicator lamp	232	discharged	59
malfunction	232	discharging	229
Tyre Pressure Loss Indicator	231	disconnecting	228
Tyre pressure	236	installation location	226
checking	237	meaning of warnings on the vehicle battery	226
Tyre Pressure Loss Indicator	231	preparation actions	227
Tyre Pressure Monitoring System		replacing	228
change the tyres	235	starting the engine with jump leads	211
Tyres		symbol definition	226
check wheels and tyres	231	Vehicle battery (12 V)	
see wheels and tyres	233	grounding point for jump starting	210
Tyres with directional tread pattern	242	Vehicle conservation	252
Tyre wear	238	aluminium parts	255
Tyre wear indicators	238	automatic washing system	253
		chrome parts	255
		cleaning the seat belts	257
		cleaning the wheels	255
		dash panel	257
		engine compartment	255
		exterior	252
		external mirrors	255
		fabric covers	257
		high pressure washing machine	253
		hollow cavities	255
		interior	257
		manual wash	253
		natural leather	257
		NT - non microfiber fabric	257
		paddings	257
		paintwork of the vehicle	253
		plastic components	257
		rubber seals	255
		seat cover handling	257
		thawing the door lock cylinder	255
		vehicle underbody protection	255
		washing the vehicle	253
		windows	255
		windscreen wipers service position	196
		wooden ornamental elements	257
		Vehicle data sticker	270
		Vehicle delivery	251
		Vehicle identification data	270
		Vehicle identification number	270
		Vehicle jack	244
		Vehicle key	60
		replacement key	60
		replacing the battery	61
		see vehicle key	60
		troubleshooting	62
		unauthorized	107
		Vehicle maintenance	
		airbag module (dash panel)	257
		cleaning the stowage compartment	257
		vinyl	257
U			
UNIT	147		
unit operation	147		
Unit code			
see Anti-theft coding	140		
Unlock			
with Keyless Access	62		
Uphill assist system	115		
USB			
connecting an external data carrier	155		
iPad controls	155		
iPhone controls	155		
iPod controls	155		
supported USB data storage units	151		
USB connection	155		
disconnect the connection	155		
unreadable	155		
USB port	131		
USB Port	133		
User profile			
settings	165		
VW Play	177		
V			
Valet mode			
VW Play	176		
Valve caps	237		
Variable luggage compartment floor	180		
Vehicle			
locking or unlocking from inside	65		
protection in case of faults	58		
stopping on downhill inclines	120		
stopping on uphill inclines	120		
unlocking or locking with Keyless Access	62		
Vehicle battery	226		
automatic consumer deactivation	229		
battery electrolyte	228		
charging	228		
check electrolyte level	227		

Vehicle modifications	260	Washing	252
plates	266	manual	253
stickers	266	with high pressure washing machine	253
Vehicle sale	4	Washing the vehicle	253
Vehicle sales		folding mirrors	91
in other countries / continents	103	What happens to passengers who have not fastened their seat belts	37
Vehicle settings		Wheel	
radio	29	shift paddle (Tiptronic)	112
Vehicle toolkit	194	Wheel bolts	244, 246
Vehicle tool kit		cap	244
contents	195	tightening torque	246
Vehicle toolkit		Wheel hub caps	
stowage	194	wheel cover	243
toolkit access	194	Wheels	236
Vehicle underbody protection	255	bolted-on trims	236
Vehicle wallet compartment	132	identification	236
Ventilation	93	Wheels and tyres	231, 233
Ventilation and heating system		avoiding damages	234
controls	93	changing a wheel	244
temperature setting	94	check wheels and tyres	234
Voice command		foreign bodies in the tyre	238
Android Auto™	147	identification	240
Apple CarPlay™	146	markings	240
Volkswagen Dealership Warranty	265	new tyres	235
Volkswagen® Genuine Parts	266	old tyres	234
Volume		replacing tyres	235
AUX-IN	166	run-in	235
Bluetooth audio	166	serial number	240
define external audio sources	166	spare wheel	239
maximum volume when turning the device on	166	speed index	241, 242
traffic report	166	storing the removed wheel	239
Volume control	141	storing tyres	234
VW Play	167	technical data	240
welcome	167	Temporary spare wheel of different size from the regular wheels	245
W		tread depth	237
Warm starting	226	tyre damage	238
Warm starting system		tyre identification number (TIN)	240
information on the warm starting system	226	tyre load capacity	242
Warning lamp		tyre pressure	236
bonnet	216	tyres with directional tread pattern	242
brake system	129	tyre types	240
braking support systems	129	tyre wear	238
seat belt	35	tyre wear indicators	238
shifting gear	114	unbalanced wheels	238
Warning lamps		valve caps	237
overview	13	wheel alignment fault	238
Warning light		wheel balancing	238
engine coolant	19	wheel rotation	234
Warning lights	58	wheels	236
Warning triangle	59	winter tyres	242
Washer fluid		Wi-Fi	
check	217	connect	171
replenish	217	forget network	171
		Window activation	71

Windows	
defrosting	94
see Window activation	71
Window washers	86
Window wiper blades	196
cleaning	196
replacing	196
Window wipers	86
automatic headlight washing system	87
functions	87
heatable windscreen washer nozzles	87
rain sensor	87
Window wipers / rear window	
windscreen / rear window wiper lever	86
Windscreen / rearwindow washers	
windscreen / rear window washers lever	86
Windscreen wiper blades	
cleaning	196
replacing	196
Windscreen wipers	
lifting the wiper arms	196
service position	196
swing the wiper arms outward	196
Windscreen wipers and washers	
trouble shooting	88
Winter driving	
fuel consumption	100
Winter tyres	242
speed limit	243
Wireless charging function	131
Wrench icon	26
X	
XDS	
see Brake support systems	127

Volkswagen Brazil works continuously to develop and improve all its vehicles. Please understand that we must therefore reserve the right to alter any part of the vehicle and its equipment or technical specifications at any time. The data provided concerning scope of delivery, appearance, performance, dimensions, weights, fuel consumption, standards and vehicle functions are all correct at the time of going to print. Some of the equipment described might not yet be available in a particular vehicle (information can be provided by your local Volkswagen Dealership), and some equipment may not be available in certain countries. No legal commitment may be inferred from the information, illustrations or descriptions in this manual.

No part of this manual may be entirely or partially reprinted, reproduced or translated without the written permission of Volkswagen do Brasil.

All rights under the copyright laws are expressly reserved by Volkswagen do Brasil. Subject to alteration and amendment.

Printed in Brazil.

© **2023 Volkswagen do Brasil**



Manual printed in paper bleached without the use of chlorine.